

FEATURES & BENEFITS

OPTIONS

For more information, visit www.hawsco.com or call (888) 640-4297.



SPECIFICATIONS

Model 9011 is the new ANSI Emergency Shower and Eyewash Testing Kit. It includes a 5-gallon bucket with lid and marked line indicating the 2 gallon mark, a shower sock and 3-piece pole to direct water into bucket, eyewash gauge, tape measure, thermometer, ANSI checklist for testing compliance, and testing instructions. All items included fit directly into the bucket for ease of transportation.

APPLICATIONS

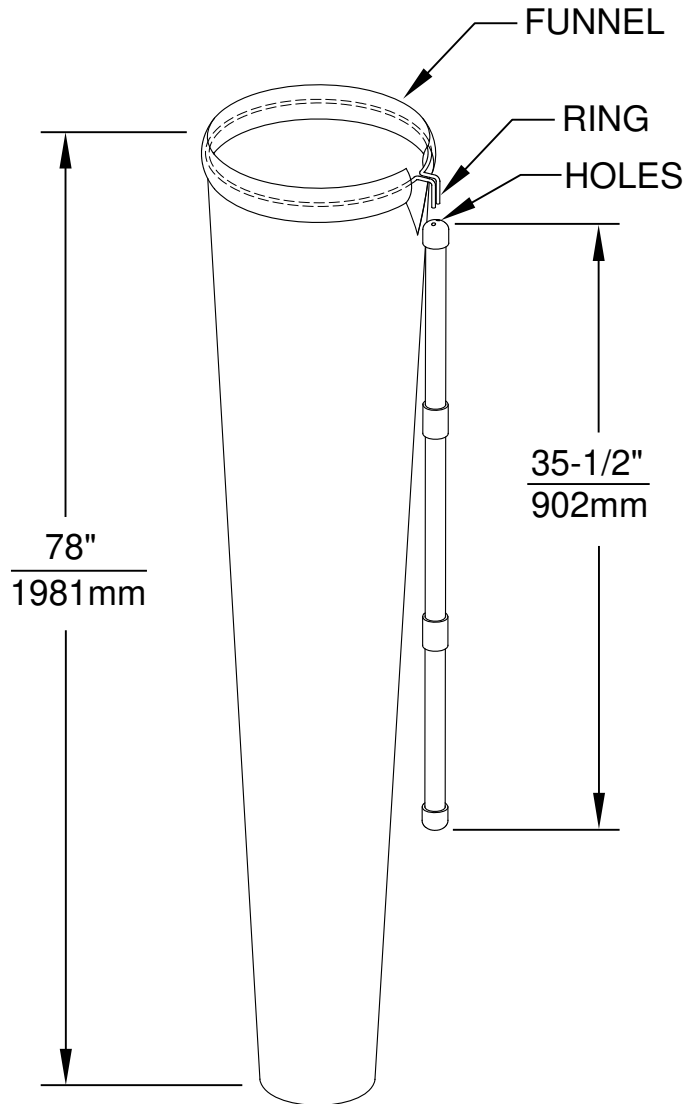

THE MODEL 9010 / 9011 SHOWER TEST KITS GUIDE THE WATER TO A FLOOR DRAIN OR CONTAINMENT BUCKET.

ASSEMBLY INSTRUCTIONS:

1. CONNECT THREE-PIECE ROD ASSEMBLY AT THE COUPLINGS (CEMENT IF DESIRED).
2. INSERT THE RING IN THE FUNNEL FOLD.
3. INSERT RING HOOKS INTO THE TWO HOLES OF THE GRAB POLE (AS SHOWN).

MODEL 9011 ONLY:

1. PLACED THE SUPPLIED COLLECTION BUCKET UNDER THE FUNNEL AND ACTIVATE THE SHOWER FOR 6 SECONDS.
2. IF THE WATER LINE IS BELOW THE BLACK LINE ON THE BUCKET THEN THE SHOWER FLOW RATE IS NON-COMPLIANT.
3. MEASURE THE TEMPERATURE OF THE WATER USING THE SUPPLIED THERMOMETER. ANSI COMPLIANT RANGE IS 60°F - 100°F (15.5°C - 37.7°C)

		1455 KLEPPE LANE SPARKS, NEVADA 89431 (775) 359-4712 FAX (775) 359-7424 E-MAIL: HAWS@HAWSOCO.COM WEBSITE: WWW.HAWSOCO.COM	
		ECN NO. REVISED PER BY: MODEL(S) ECN: 5161 MJ DATE: 3/93 FV	PART NUMBER 0002080204 REVISION 5
DRAWN: CLF APPROVED: FV	DATE: 01/30/17	SCALE: 1:1 DRAWING TYPE: INSTALLATION	SIZE: A SHEET 1 OF 1