

NOTES:

1. HOLD ROUGH-IN DIMENSIONS $\pm 1/4"$ (6.4mm).
2. WHEN INSTALLING THIS UNIT, LOCAL, STATE, OR FEDERAL CODES SHOULD BE ADHERED TO. FOR CHILD-HEIGHT INSTALLATIONS ON 1107 MODELS, REDUCE DIMENSIONS MARKED (*) BY 3" [76mm].

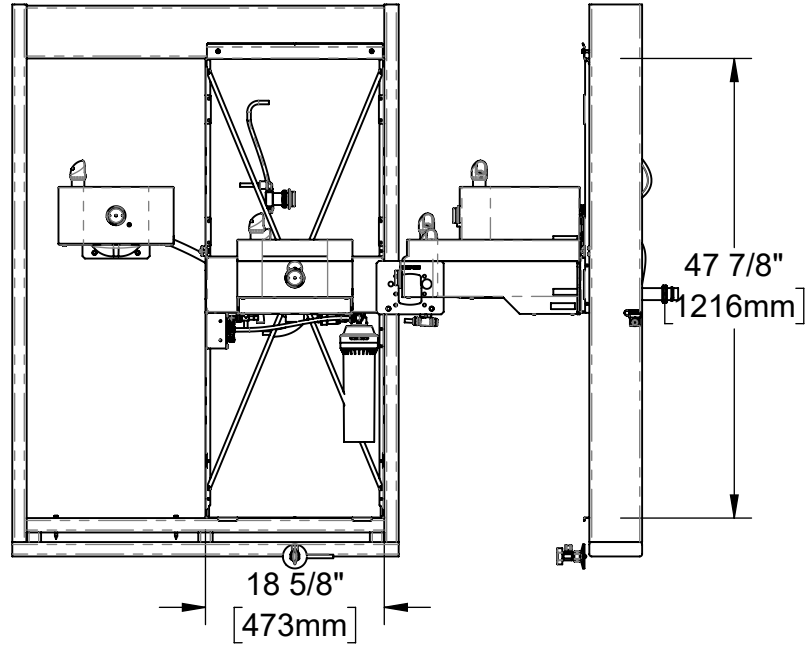

HS11
(SINGLE FOUNTAIN MODELS)

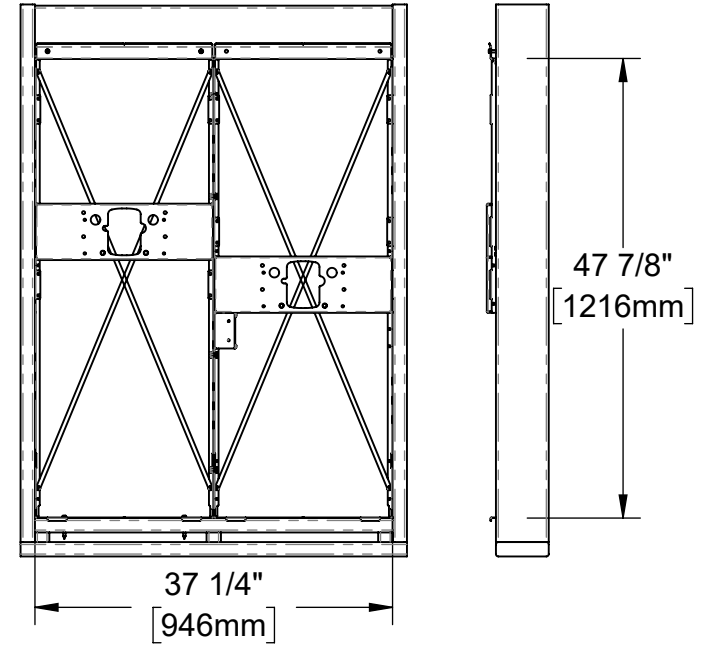

HS12
(DUAL FOUNTAIN MODELS)

			1455 KLEPPE LANE SPARKS, NEVADA 89431 (775) 359-4712 FAX (775) 359-7424 E-MAIL: HAWS@HAWSO.COM WEBSITE: WWW.HAWSO.COM		
			ECN: 6000 REV. ECN: 6000 BY: DHP MODEL(S) HS11 & HS12, IN-WALL FRAME PART NUMBER 0510002253.D DRAWN: DHP DATE: 12/15/22 CHKD: DHP REVISION 1 APPROVED: JU DATE: 07/08/24 SCALE: 1:20 DRAWING TYPE: INSTALLATION SIZE: A SHEET 1 OF 6		

3. ROUGH IN WALL CAVITY WITH DIMENSIONS SHOWN. ROUGH IN ELECTRICAL, WASTE PIPING, AND WATER SUPPLY AS REQUIRED. BE SURE ELECTRICAL, WASTE PIPING, AND WATER SUPPLY IS CLEAR OF THE INSTALLED LOCATION OF THE CHILLER, IN WALL FRAME, AND BOTTLE FILLER.

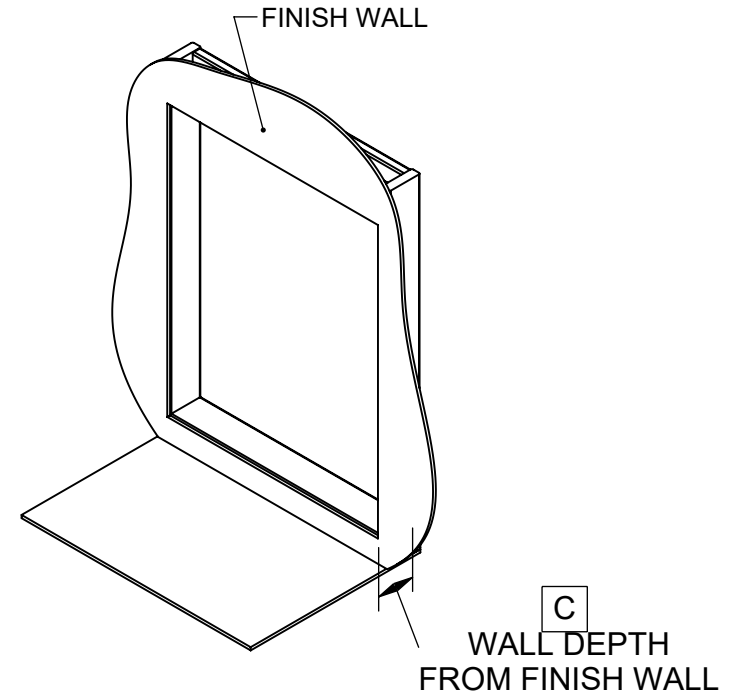
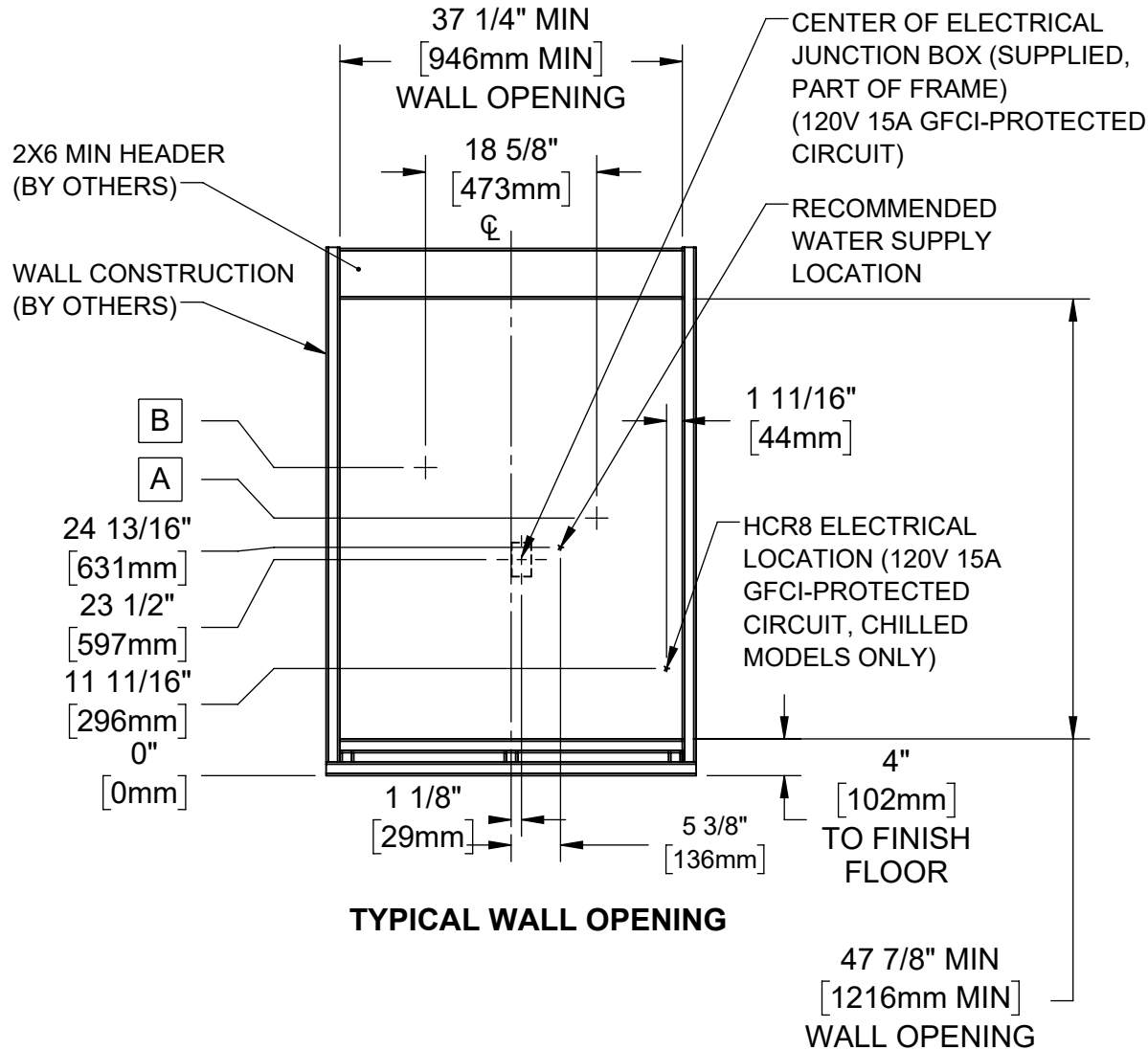

	C
CHILLED MODELS	11" MIN [279mm] MIN
NON-CHILLED MODELS	6" MIN [152mm MIN]

	A	B	
FOUNTAIN MODELS	LOW SIDE DRAIN	HIGH SIDE DRAIN	WASTE BEND SIZE
1001/1011	28" [711mm]	33 1/2" [851mm]	1-1/4"
1107/1117	27 5/16" [694mm]	32 13/16" [834mm]	1-1/4"
1109/1119	28 1/4" [718mm]	33 3/4" [857mm]	1-1/4"

1455 KLEPPE LANE
SPARKS, NEVADA 89431
(775) 359-4712 FAX (775) 359-7424
E-MAIL: HAWS@HAWSO.COM
WEBSITE: WWW.HAWSO.COM

ECN: 6000	REV. ECN: 6000	BY: DHP	MODEL(S) HS11 & HS12, IN-WALL FRAME	PART NUMBER 0510002253.D
DRAWN: DHP	DATE: 12/15/22	CHKD: DHP		REVISION 1
APPROVED: JU	DATE: 07/08/24	SCALE: 1:20	DRAWING TYPE: INSTALLATION	SIZE: A SHEET 2 OF 6

4. BOLT FRAMES TOGETHER USING 4X 5/16" BOLTS AND NUTS AS SHOWN (DETAIL A). INSTALL 4X PANEL CLIPS (DETAIL B) USING #10 NUTS (SUPPLIED).
5. MOUNT FRAME ASSEMBLY INTO WALL CAVITY USING 16X STRUCTURAL SCREWS (NOT SUPPLIED), USE SHIMS AS NEEDED AND ENSURE THE FRAME IS SQUARE. ON CHILLED MODELS, DO NOT INSTALL THE 2X STRUCTURAL SCREWS IN THE BASE OF THE RIGHT SIDE FRAME UNTIL THE REST OF THE UNIT IS BEING INSTALLED.

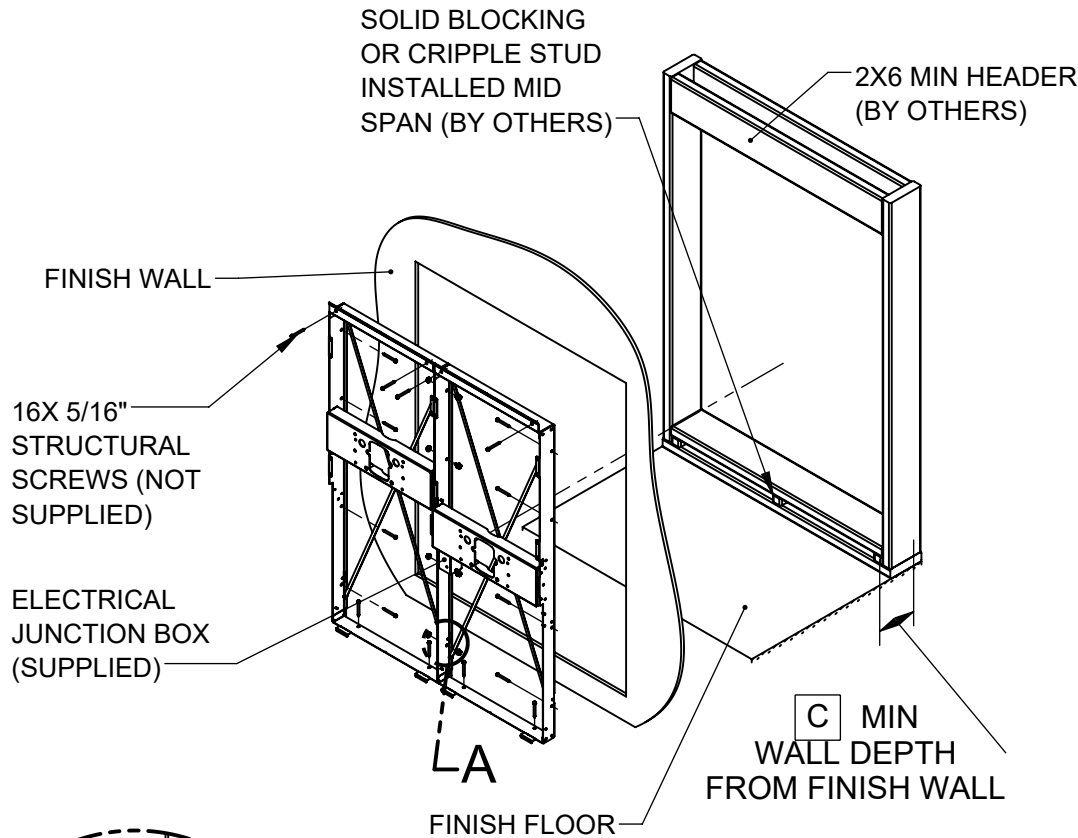

FRAME INSTALLATION

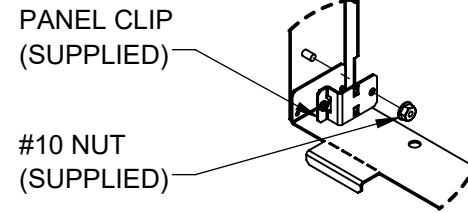

**DETAIL B
PANEL CLIP
INSTALL
(4 PLACES)**

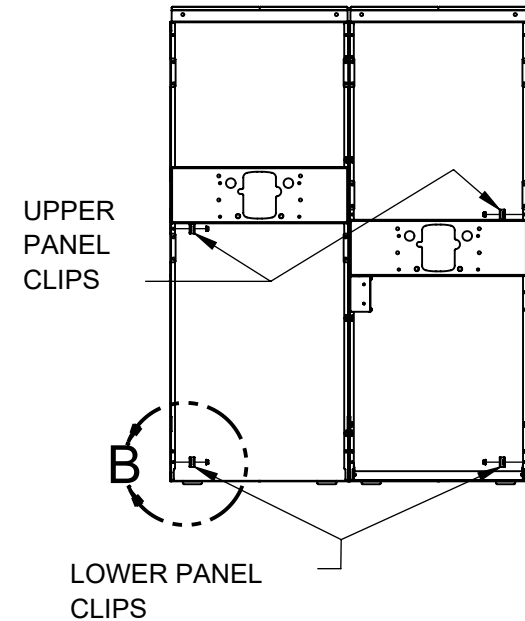

PANEL CLIP INSTALLATION

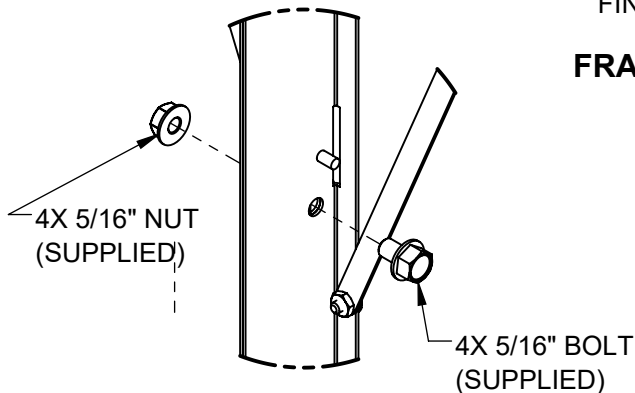

DETAIL A

			1455 KLEPPE LANE SPARKS, NEVADA 89431 (775) 359-4712 FAX (775) 359-7424 E-MAIL: HAWS@HAWSO.COM WEBSITE: WWW.HAWSO.COM	
ECN: 6000	REV. ECN: 6000	BY: DHP	MODEL(S)	PART NUMBER
DRAWN: DHP	DATE: 12/15/22	CHKD: DHP	HS11 & HS12, IN-WALL FRAME	0510002253.D
APPROVED: JU	DATE: 07/08/24		SCALE: 1:20 DRAWING TYPE: INSTALLATION	REVISION 1
			SIZE: A	SHEET 3 OF 6

6. ROUGH IN WALL CAVITY WITH DIMENSIONS SHOWN. ROUGH IN ELECTRICAL, WASTE PIPING, AND WATER SUPPLY AS REQUIRED. BE SURE ELECTRICAL, WASTE PIPING, AND WATER SUPPLY IS CLEAR OF THE INSTALLED LOCATION OF THE IN WALL FRAME, AND BOTTLE FILLER.

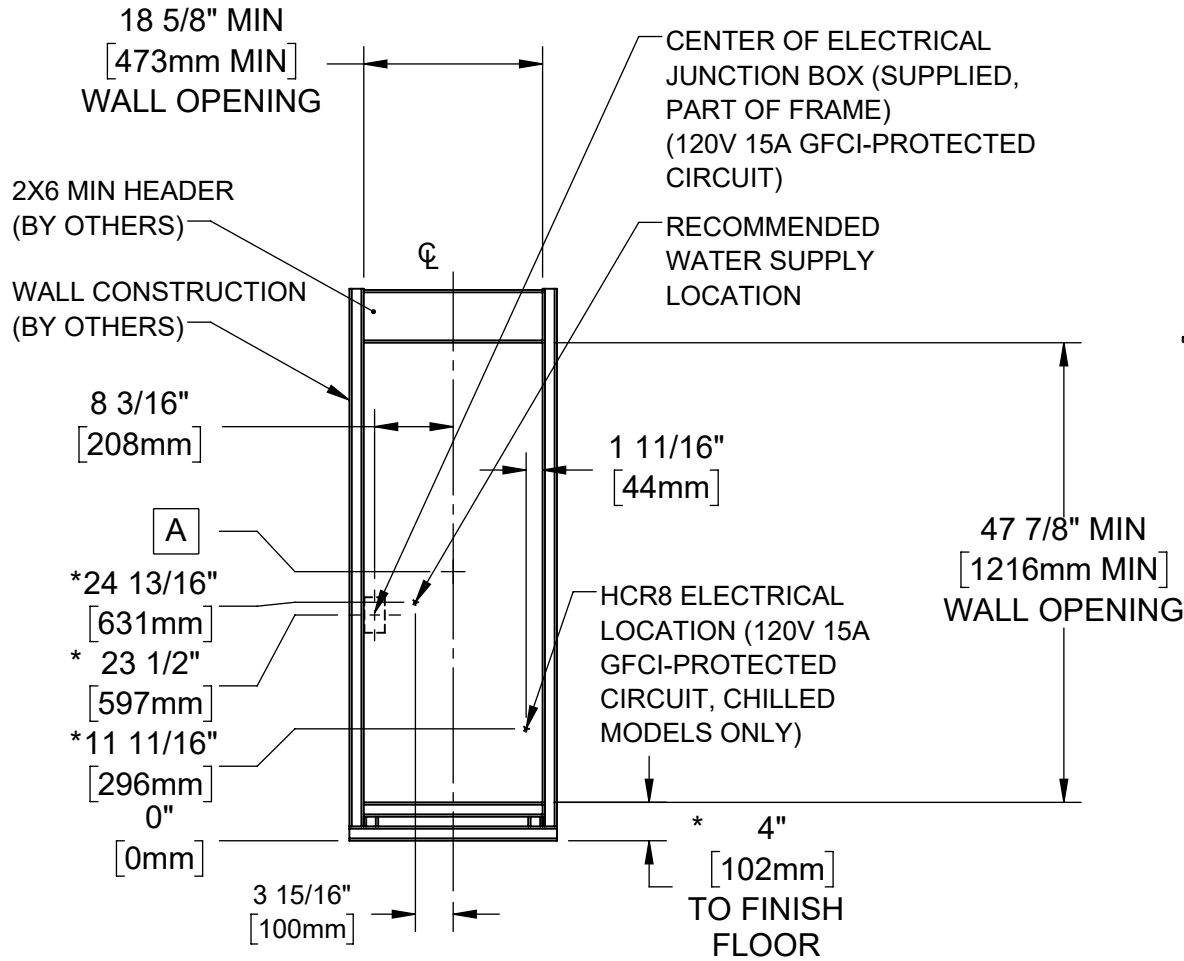

TYPICAL WALL OPENING

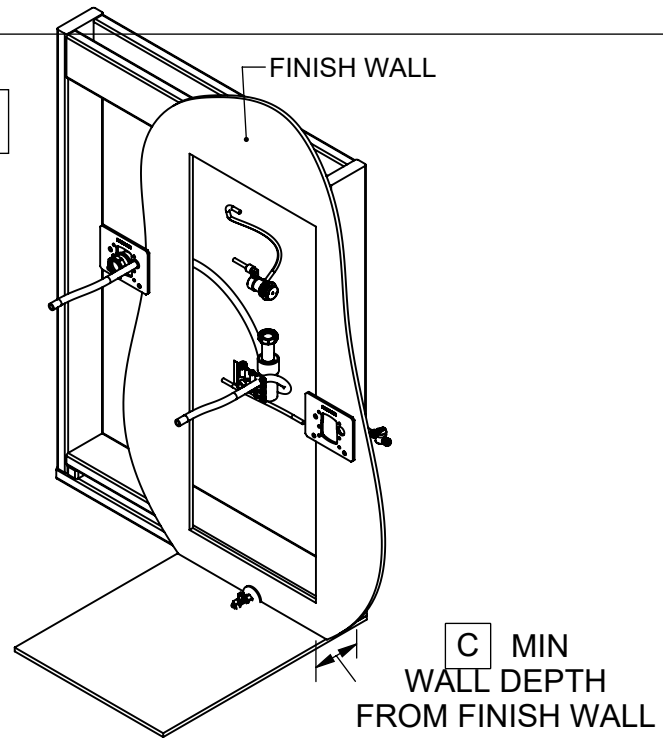

C MIN WALL DEPTH FROM FINISH WALL

	C (REF)
CHILLED MODELS	11" MIN [279mm] MIN
NON-CHILLED MODELS	6" MIN [152mm MIN]

	A	
FOUNTAIN MODELS	DRAIN HEIGHT	WASTE BEND SIZE
1001/1011	28" [711mm]	1-1/4"
1107/1117	*27 5/16" [694mm]	1-1/4"
1109/1119	28 1/4" [718mm]	1-1/4"

Haws
 Since 1906

1455 KLEPPE LANE
SPARKS, NEVADA 89431
(775) 359-4712 FAX (775) 359-7424
E-MAIL: HAWS@HAWS.CO.COM
WEBSITE: WWW.HAWS.CO.COM

ECN: 6000	REV. ECN: 6000	BY: DHP	MODEL(S) HS11 & HS12, IN-WALL FRAME	PART NUMBER 0510002253.D
DRAWN: DHP	DATE: 12/15/22	CHKD: DHP		REVISION 1
APPROVED: JU	DATE: 07/08/24	SCALE: 1:20	DRAWING TYPE: INSTALLATION	SIZE: A SHEET 4 OF 6

7. INSTALL 4X PANEL CLIPS (DETAIL C) USING #10 NUTS (SUPPLIED).
8. MOUNT FRAME ASSEMBLY INTO WALL CAVITY USING 12X STRUCTURAL SCREWS (NOT SUPPLIED), USE SHIMS AS NEEDED AND ENSURE THE FRAME IS SQUARE. DO NOT INSTALL THE 2X STRUCTURAL SCREWS IN THE BASE OF THE FRAME UNTIL THE REST OF THE UNIT IS BEING INSTALLED.

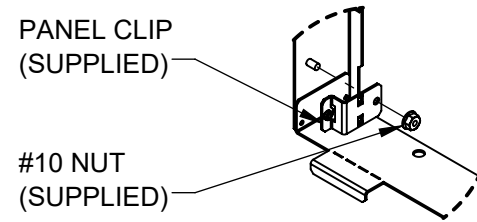

DETAIL C
PANEL CLIP
INSTALL
(4 PLACES)

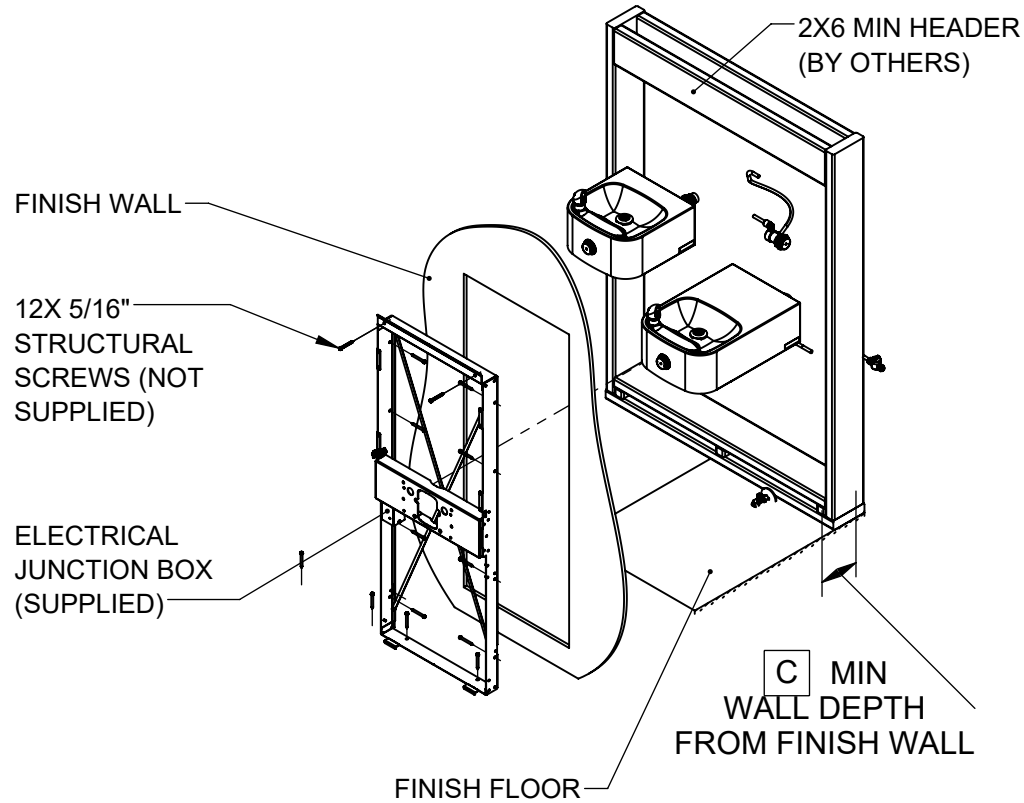

FRAME INSTALLATION

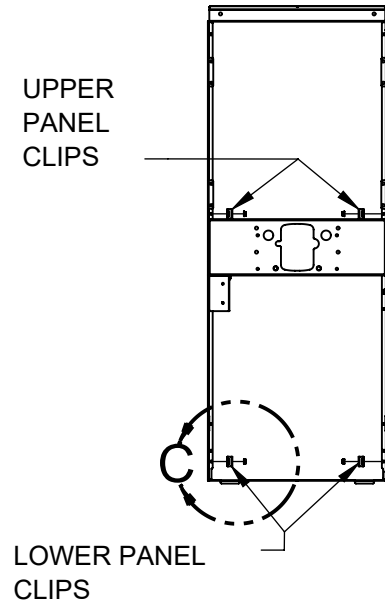

PANEL CLIP INSTALLATION



1455 KLEPPE LANE
SPARKS, NEVADA 89431
(775) 359-4712 FAX (775) 359-7424
E-MAIL: HAWS@HAWSO.COM
WEBSITE: WWW.HAWSO.COM

ECN: 6000	REV. ECN: 6000	BY: DHP	MODEL(S) HS11 & HS12, IN-WALL FRAME	PART NUMBER 0510002253.D
DRAWN: DHP	DATE: 12/15/22	CHKD: DHP		REVISION 1
APPROVED: JU	DATE: 07/08/24	SCALE: 1:20	DRAWING TYPE: INSTALLATION	SHEET 5 OF 6

8. ACCESS TO THE BACK SIDE OF THE WALL IS REQUIRED TO INSTALL AND MAINTAIN 1XXXHS MODELS. THESE MODELS ARE SUITABLE FOR WALLS WITH DRYWALL (5/8" MAX) SHEATHING ONLY.
9. INSTALLATION PROCESS OF FRAME(S) FOR SINGLE AND DOUBLE FOUNTAIN MODELS IS THE SAME. INSTALLATION OF A SINGLE FOUNTAIN MODEL IS SHOWN FOR REFERENCE.
10. REMOVE DRYWALL TABS FROM THE BOTTOM OF THE FRAMES BY BENDING ALONG PERFORATIONS (DETAIL D).
11. MOUNT FRAME ASSEMBLY INTO WALL CAVITY FROM THE BACK SIDE OF THE FINISH WALL USING STRUCTURAL SCREWS (NOT SUPPLIED, 12X FOR SINGLE FTN MODELS, 16X FOR DUAL FTN MODELS), USE SHIMS AS NEEDED AND ENSURE THE FRAME IS SQUARE.
12. INSTALL THE 2X PANEL CLIPS USING #10 NUTS (SUPPLIED) AS SHOWN (DETAIL E).

REAR ACCESS FRAME INSTALLATION

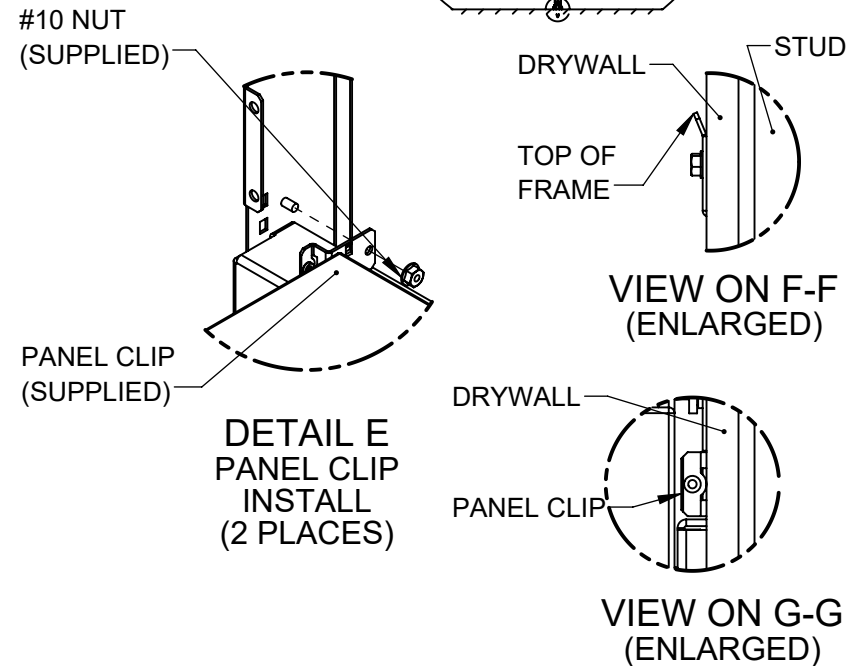
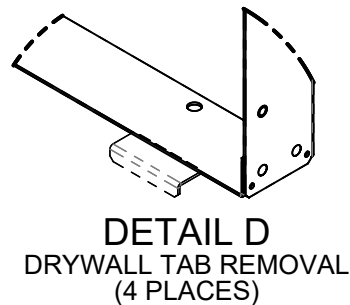
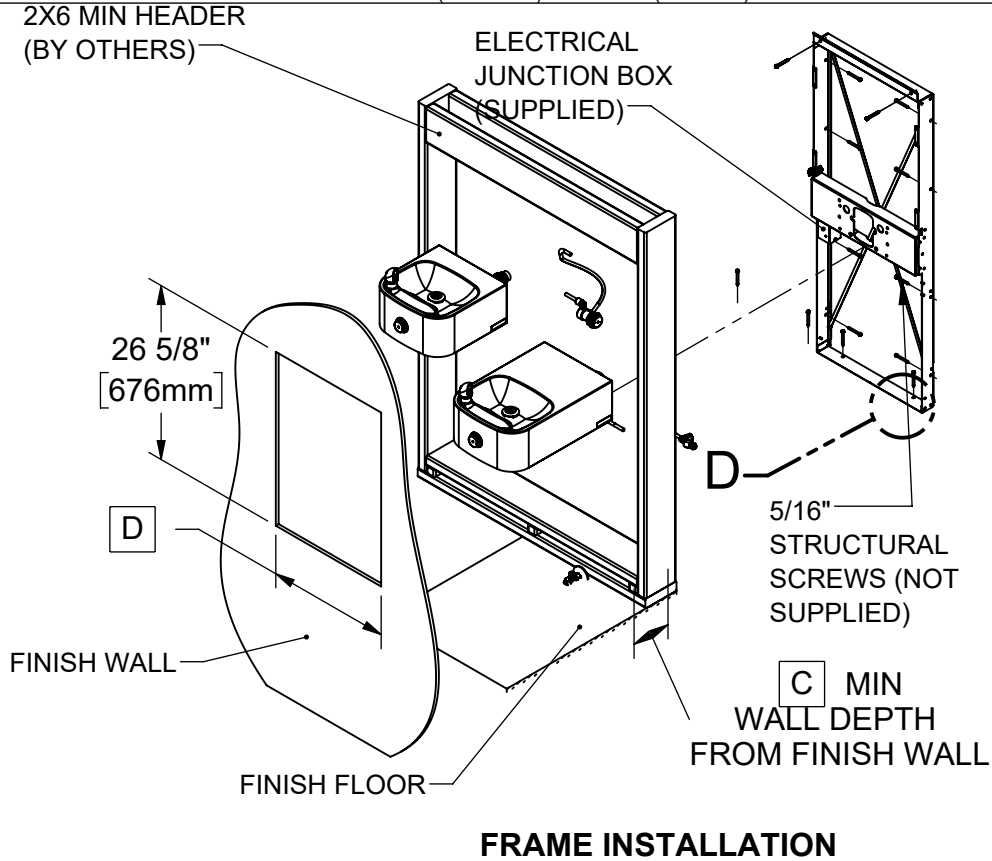

	D
SINGLE FTN MODELS	18 5/8" [473mm]
DUAL FTN MODELS	37 1/4" [946mm]



Haws
Since 1906

1455 KLEPPE LANE
SPARKS, NEVADA 89431
(775) 359-4712 FAX (775) 359-7424
E-MAIL: HAWS@HAWS.CO.COM
WEBSITE: WWW.HAWS.CO.COM

ECN: 6000	REV. ECN: 6000	BY: DHP	MODEL(S)	PART NUMBER
DRAWN: DHP	DATE: 12/15/22	CHKD: DHP	HS11 & HS12, IN-WALL FRAME	0510002253.D
APPROVED: JU	DATE: 07/08/24	SCALE: 1:20	DRAWING TYPE: INSTALLATION	REVISION: 1
			SIZE: A	SHEET 6 OF 6