

FEATURES & BENEFITS

CONSTRUCTION

Heavy-duty cast-iron ADA accessible bowl with a glossy white enamel finish is designed for the toughest of applications, and at the same time is gentle to all users with its soft rounded corners. Unit also ships with vandal-resistant bottom plates to provide added peace of mind.

BOTTLE FILLER

Vandal-resistant, 14-gauge white powder-coated Type 304 stainless steel bottle filler housing with push button operation and 1 gpm (3.78 L) laminar flow.

BUBBLER HEADS

Polished chrome-plated brass bubbler head with integral laminar flow prevents splashing while providing a superior flow pattern. The integral 11/16" dia. basin shank and stainless anti-rotation roll pin for vandal resistance strength. Shielded, angled stream opening provides a steady, sanitary source of drinking water at .45 gpm.

FOUNTAIN VALVES

The push-button activated valves have all stainless steel bodies, with chrome plated brass push button assemblies which allow for front access to water stream adjustment, water control cartridge, and water supply strainer replacement without having to go through the bottom plate. Operating pressure range of 30 to 90 psi (2.1 to 6.2 bar).

VANDAL RESISTANT

The bubbler head, push buttons, drain strainer and bottom plates are locked in place, discouraging unwanted vandal tampering.

OPTIONS

- Water Filter: Model 6480 filter kit with 3000 gallon carbon block filter, filter head, and mounting bracket.
- Back Panel: Model BP15WC, one-piece panel for fountain/bottle filler combination when child-height ADA requirements are needed.
- Support Frame: Model 6800 In-wall floor mounted fixture support legs, welded steel 4-bolt floor flanges, and supplied with 'U' bolts and hardware.

For more information, visit www.hawsc.com or call (888) 640-4297.



SPECIFICATIONS



Model 1311P wall mounted vandal-resistant ADA drinking fountain and bottle filler shall include a white enameled-iron basin with 14 gauge Type 304 powder-coated Stainless Steel bottle filler bracket, 100% lead-free waterways, vandal-resistant push-button operated stainless steel valves with front-accessible cartridge and flow adjustment, polished chrome-plated brass vandal-resistant bubbler head with integral anti-squirt flow, 1 gpm (3.78 L) laminar flow bottle filler with in-wall 3/16" thick steel mounting plate, chrome plated brass vandal-resistant waste strainer, vandal-resistant bottom plates, and a 1-1/4" NPT trap.

APPLICATIONS

Perfect for either public or private settings, our gleaming white enameled iron series is one of the sturdiest wall mounted fountains Haws produces. This series is precisely mounted, making it a nice addition to any surrounding. Elegant gloss finish and color consistency throughout the enameled iron maintain the fountains overall appeal so it always remains looking as new as it did when it was installed. Specifically, this type of wall mounted drinking fountain may be placed in settings such as: parks, schools, and other indoor/outdoor environments where the temperature remains above freezing. Model meets all current Federal Regulations for the disabled including those in the Americans with Disabilities Act. Haws manufactures drinking fountains, faucets and electric water coolers to be lead-free by all known definitions including NSF/ANSI/CAN 61-Section 9, NSF/ANSI/ CAN 372, California Proposition 65, and the Federal Safe Drinking Water Act. Product is compliant to California Health and Safety Code 116875 (AB 1953-2006), and 116876 (AB 100) "NSF/ANSI/CAN 61: Q ≤ 1".

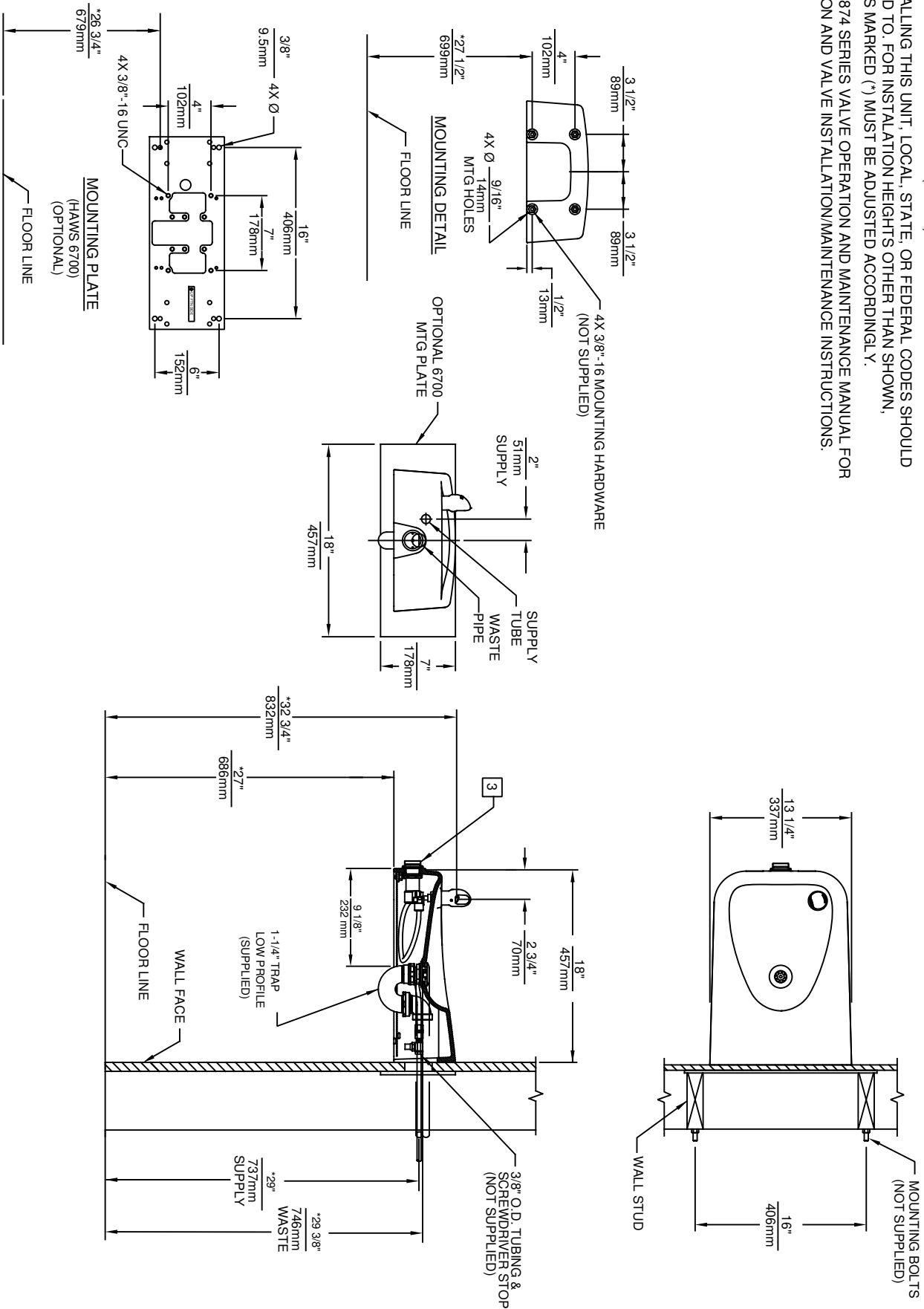

1. HOLD ROUGH-IN DIMENSIONS ± 1/4" (6.4MM).
2. WHEN INSTALLING THIS UNIT, LOCAL, STATE, OR FEDERAL CODES SHOULD BE ADHERED TO. FOR INSTALLATION HEIGHTS OTHER THAN SHOWN, DIMENSIONS MARKED (*) MUST BE ADJUSTED ACCORDINGLY.
3. REFER TO 5874 SERIES VALVE OPERATION AND MAINTENANCE MANUAL FOR PUSH BUTTON AND VALVE INSTALLATION/MAINTENANCE INSTRUCTIONS.

Haws

1459 KLEPPE LANE
SPARKS, NEVADA, 89431
(775) 359-4712 FAX (775) 359-7424
E-MAIL: HAWS@HAWS.CO.COM
WEBSITE: WWW.HAWS.CO.COM

ECN NO. REVISED PER BY:	MODEL(S)
5010 ECN: S258 JP	1311
DATE: 08/25/15	
CHKD: GC	
DATE: 11/23/17	
SCALE: 1:14	DRAWING TYPE: INSTALLATION
SIZE: A	SHEET: 1 OF 1
REVISION: 4	

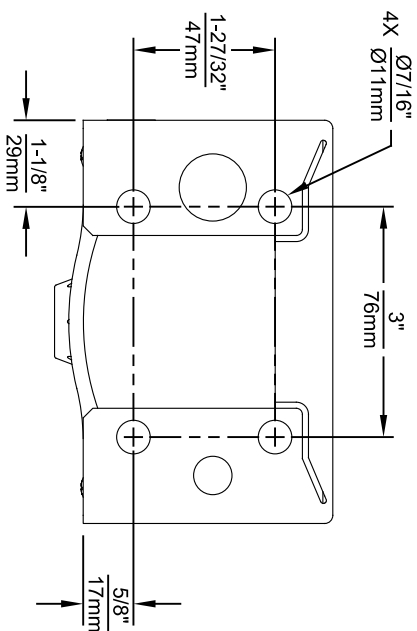
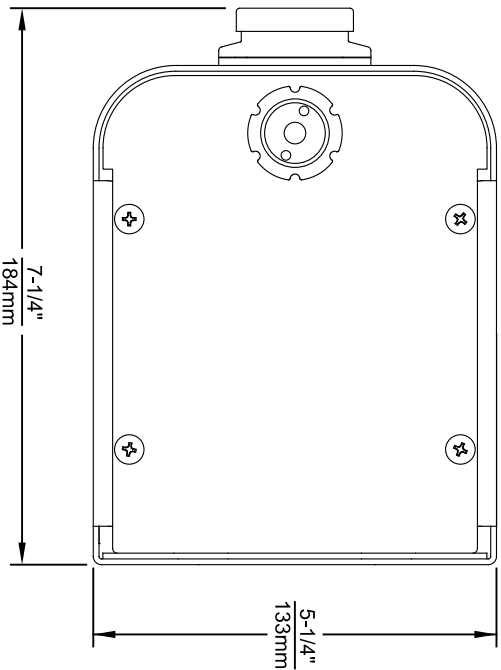
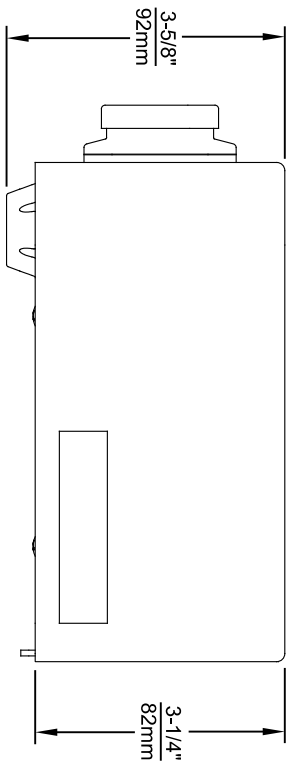

1920 SERIES MOUNTING HOLE LOCATIONS
(3/8\"-16 UNC MOUNTING HARDWARE NOT SUPPLIED)

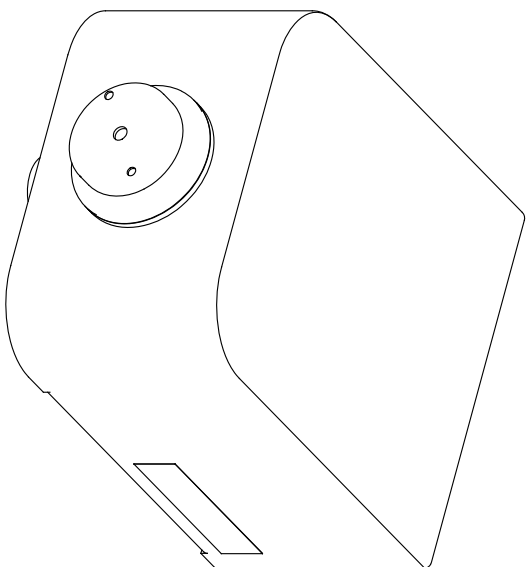

NOTES:

- SEE SHEETS 2 THRU 7 FOR BOTTLE FILLER ADULT ADA HEIGHT APPLICATIONS AND SHEET 8 FOR CHILD ADA HEIGHT APPLICATIONS.
- WHEN INSTALLING THIS UNIT, LOCAL, STATE OR FEDERAL CODES SHOULD BE ADHERED TO FOR INSTALLATION LOCATIONS, WASTE & SUPPLY REQUIREMENTS OTHER THAN SHOWN.

		1455 KLEPPLELANE SPARKS, NEVADA 89431 (775) 359-4712 FAX (775) 359-7424 E-MAIL: HAWS@HAWSCO.COM WEBSITE: WWW.HAWSCO.COM	
EGN NO. REVISED PER BY: 5081 FV	MODEL(S) 1920/1920HPS/1920W	PART NUMBER 0510000490.D	REVISION 12
DRAWN: DS DATE: 05/25/16 CHK'D: JC APPROVED: FV	SCALE: N/A DRAWING TYPE:	INSTALLATION:	SIZE: A1 SHEET: 1 OF 8

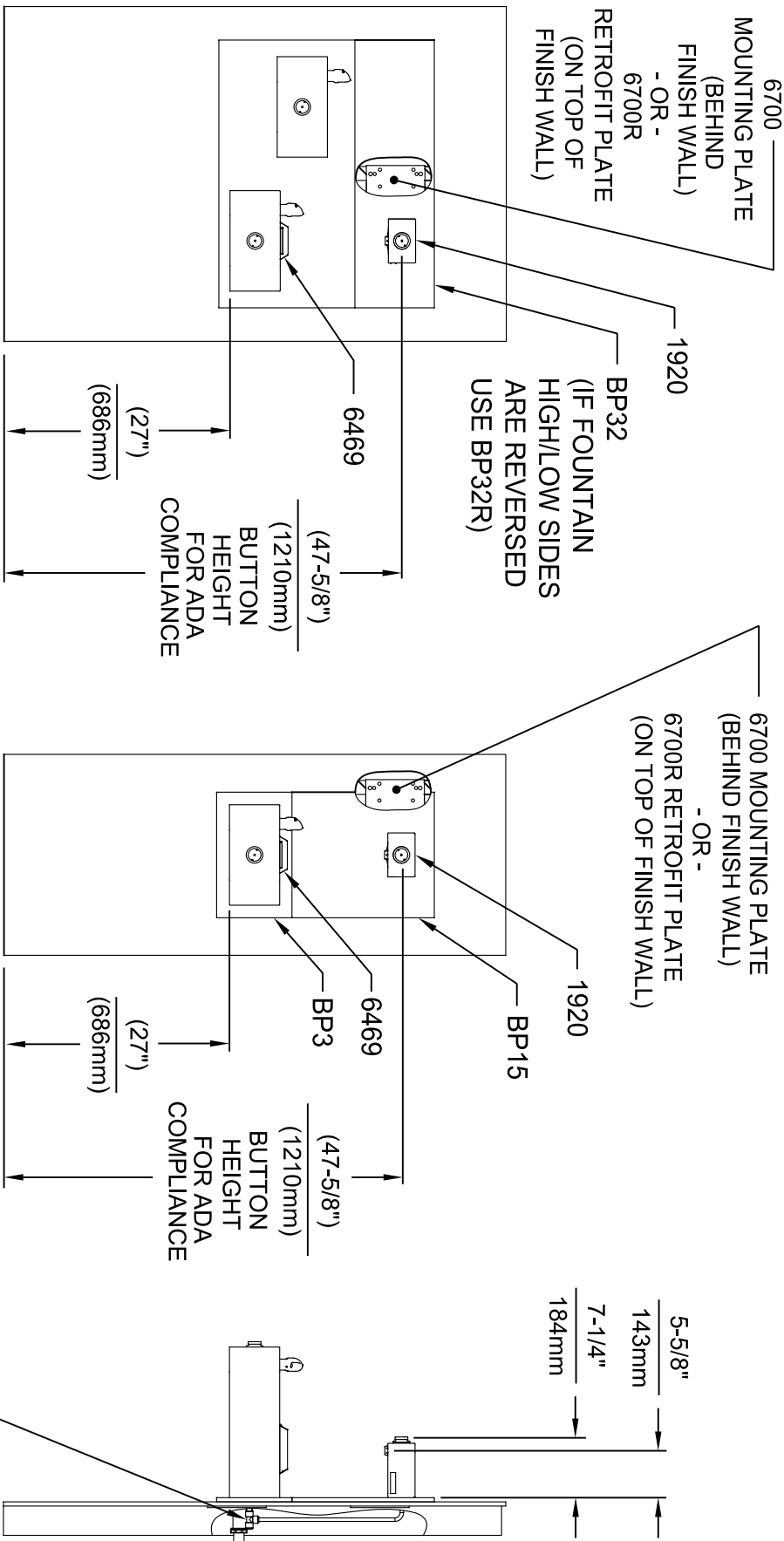

INSTALLATION ABOVE HAWS 1119 & H1119.8 SERIES

**INSTALLATION ABOVE HAWS 1109 & H1109.8 SERIES
SEE SHEET 8 FOR INSTALLATION AT CHILD HEIGHT**

* IF YOUR FOUNTAIN IS THIS STYLE USE THESE DIMENSIONS

1. SEE SEPARATE INSTALLATION DRAWINGS FOR MOUNTING PLATES AND BACK PANELS (SHOWN FOR REFERENCE - NOT SUPPLIED).
2. WHEN INSTALLING THIS UNIT, LOCAL, STATE OR FEDERAL CODES SHOULD BE ADHERED TO FOR INSTALLATION LOCATIONS, WASTE & SUPPLY REQUIREMENTS OTHER THAN SHOWN.

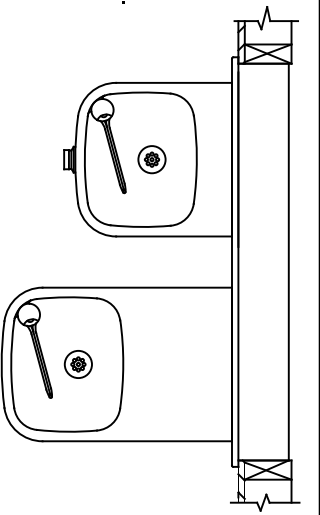

3/8" O.D. SUPPLY TUBING AND 3/8" O.D. PUSH-IN TEE SUPPLIED. (CONNECT TO FOUNTAIN SUPPLY LINE)



1455 KLEPPLE LANE
SPARKS, NE VADA 89431
(775) 359-4712 FAX (775) 359-1424
E-MAIL: HAWS@HAWSCO.COM
WEBSITE: WWW.HAWSCO.COM

EGN NO. REVISED PER BY:	MODEL(S)	SCALE:	DATE:	INSTALLATION:
5081 FV	1920/1920HPS/1920W	N/A	04/19/24	
DRAWN: M.J.		DRAWING TYPE:		SIZE: A1 SHEET 3 OF 8
CHKD: J.C.				REVISION: 12
APPROVED: F.V.				
PART NUMBER: 0510000490.D				

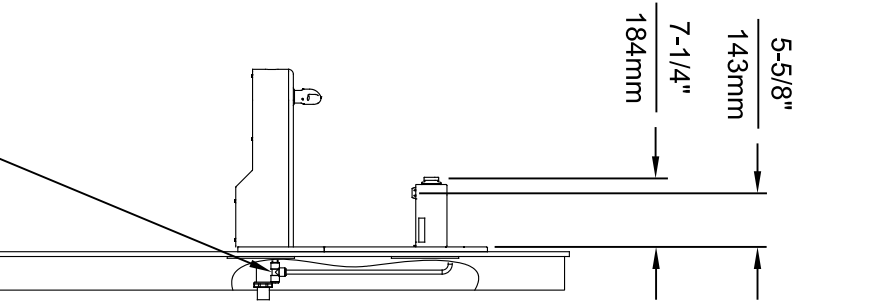
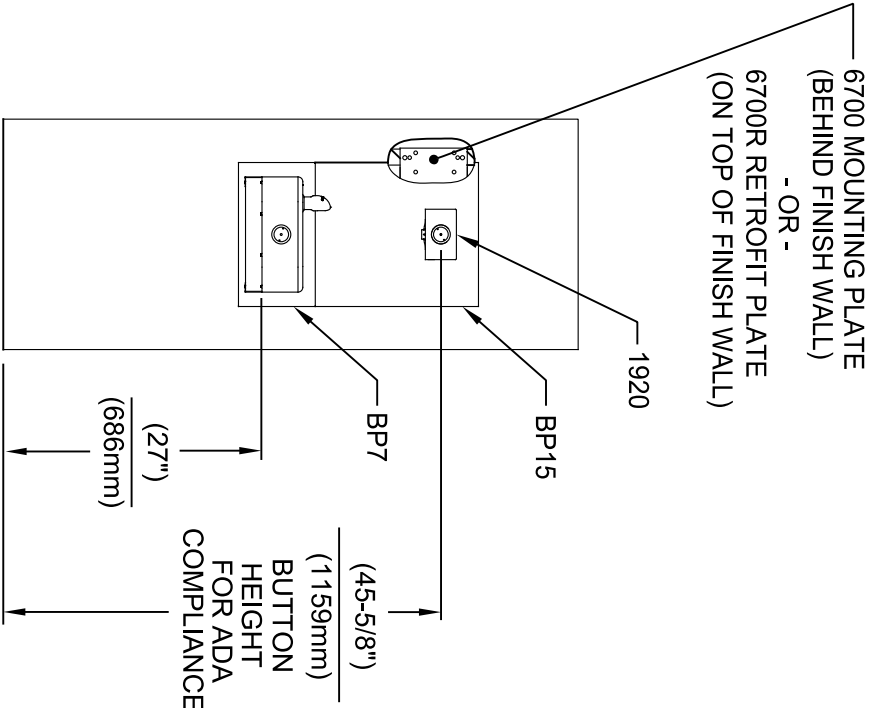
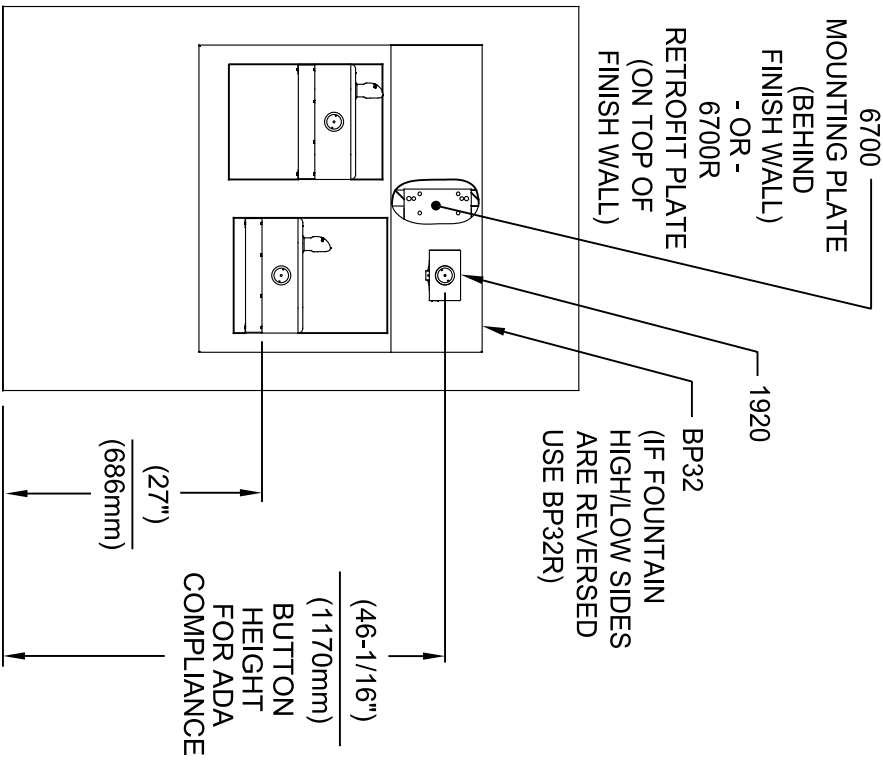

INSTALLATION ABOVE HAWS 1117L & H1117.8 SERIES

**INSTALLATION ABOVE HAWS 1107L & H1107.8 SERIES
SEE SHEET 8 FOR INSTALLATION AT CHILD HEIGHT**

* IF YOUR FOUNTAIN IS THIS STYLE USE THESE DIMENSIONS

1. SEE SEPARATE INSTALLATION DRAWINGS FOR MOUNTING PLATES AND BACK PANELS (SHOWN FOR REFERENCE - NOT SUPPLIED).

2. WHEN INSTALLING THIS UNIT, LOCAL, STATE OR FEDERAL CODES SHOULD BE ADHERED TO FOR INSTALLATION LOCATIONS, WASTE & SUPPLY REQUIREMENTS OTHER THAN SHOWN.

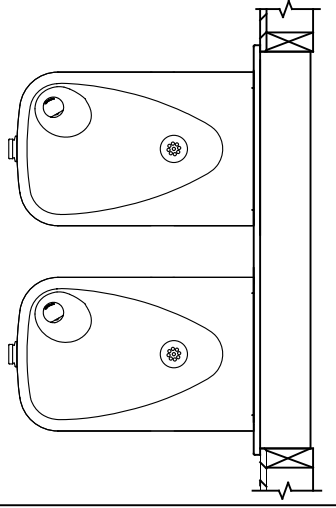

3/8" O.D. SUPPLY TUBING AND 3/8" O.D. PUSH-IN TEE SUPPLIED. (CONNECT TO FOUNTAIN SUPPLY LINE)

Haws
Since 1906

1455 KLEPPLELANE
SPARKS, NEVADA 89431
(775) 359-4712 FAX (775) 359-424
E-MAIL: HAWS@HAWS.CO.COM
WEBSITE: WWW.HAWS.CO.COM

EGN NO. REVISED PER BY:	MODEL(S)	SCALE:	DATE:	INSTALLATION:
5081 FV	1920/1920HPS/1920W	N/A	04/19/24	
DRAWN:	DATE:	CHK'D:	DATE:	SIZE:
ML	01/30/17	JC		A1
APPROVED:	DATE:	SCALE:	N/A	DRAWING TYPE:
FV				12
PART NUMBER:	REVISION:			
0510000490.D				

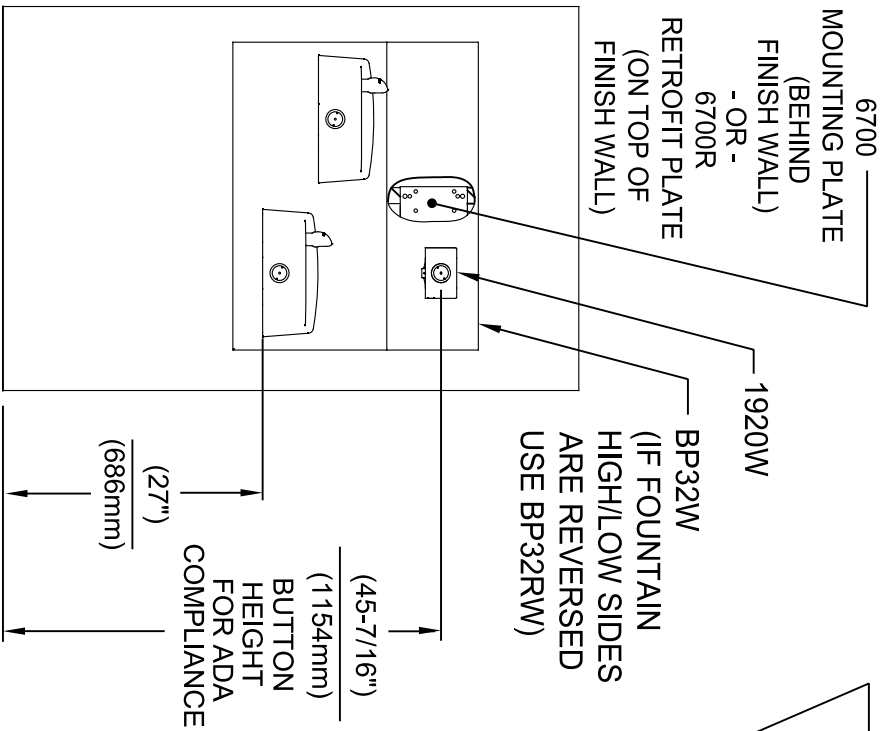

INSTALLATION ABOVE HAWS 1501

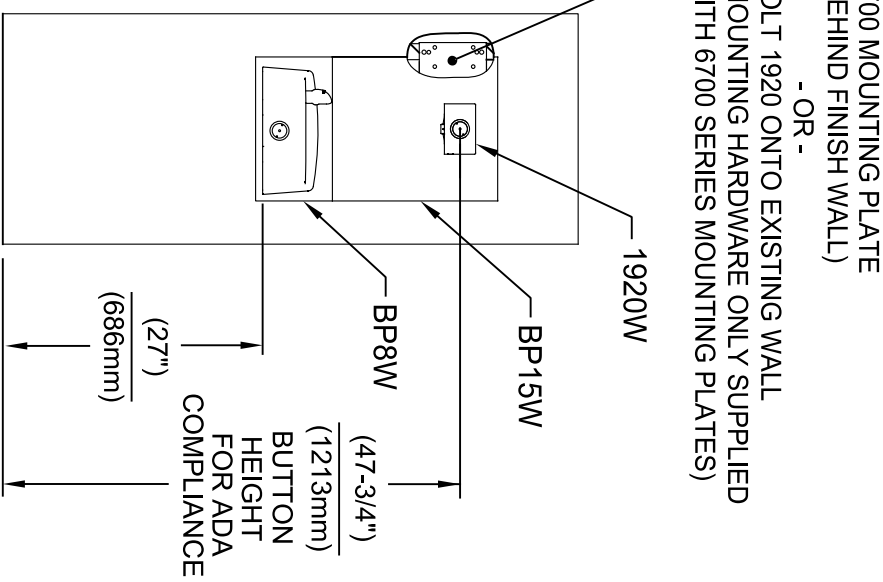

**INSTALLATION ABOVE HAWS 1311
SEE SHEET 8 FOR INSTALLATION AT CHILD HEIGHT**

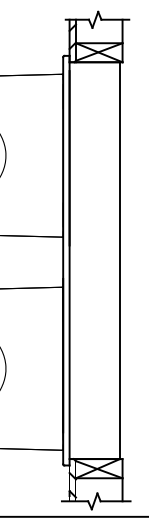
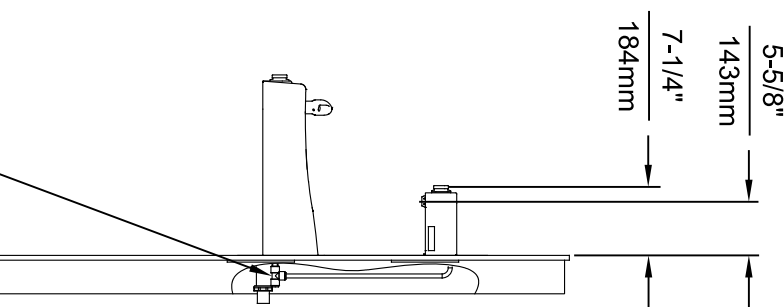

* IF YOUR FOUNTAIN IS THIS STYLE USE THESE DIMENSIONS

1. SEE SEPARATE INSTALLATION DRAWINGS FOR MOUNTING PLATES AND BACK PANELS (SHOWN FOR REFERENCE - NOT SUPPLIED).
2. WHEN INSTALLING THIS UNIT, LOCAL, STATE OR FEDERAL CODES SHOULD BE ADHERED TO FOR INSTALLATION LOCATIONS, WASTE & SUPPLY REQUIREMENTS OTHER THAN SHOWN.

5-5/8"
143mm
7-1/4"
184mm

3/8" O.D. SUPPLY TUBING AND 3/8" O.D. PUSH-IN TEE SUPPLIED. (CONNECT TO FOUNTAIN SUPPLY LINE)

 <p>Haws Since 1906</p>		<p>1455 KLEPPLE LANE SPARKS, NEVADA 89431 (775) 359-4712 FAX (775) 359-7424 E-MAIL: HAWS@HAWSCO.COM WEBSITE: WWW.HAWSCO.COM</p>	
<p>EGN NO. REVISED PER BY: FV 5081 EGN: 5972 DRAWN: DATE: 02/19/17 ML CHK'D: JC APPROVED: DATE: 04/19/24</p>	<p>MODEL(S) 1920/1920HPS/1920W</p>	<p>SCALE: N/A DRAWING TYPE:</p>	<p>INSTALLATION: SIZE: A1 SHEET: 5 OF 8 PART NUMBER: 0510000490.D REVISION: 12</p>

6700 MOUNTING PLATE
(BEHIND FINISH WALL)
- OR -
BOLT 1920 ONTO EXISTING WALL
(MOUNTING HARDWARE ONLY SUPPLIED
WITH 6700 SERIES MOUNTING PLATES)

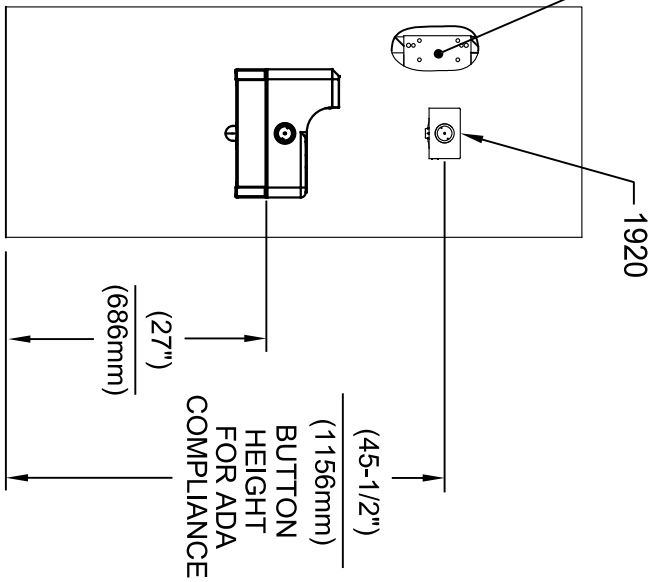

INSTALLATION ABOVE HAWS 1047

* IF YOUR FOUNTAIN IS THIS STYLE USE THESE DIMENSIONS

1. SEE SEPARATE INSTALLATION DRAWINGS FOR MOUNTING PLATES AND BACK PANELS (SHOWN FOR REFERENCE - NOT SUPPLIED).
2. WHEN INSTALLING THIS UNIT, LOCAL, STATE OR FEDERAL CODES SHOULD BE ADHERED TO FOR INSTALLATION LOCATIONS, WASTE & SUPPLY REQUIREMENTS OTHER THAN SHOWN.

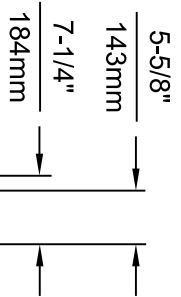
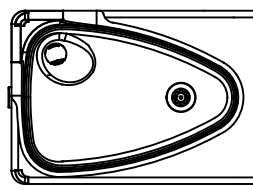

3/8" O.D. SUPPLY TUBING AND 3/8" O.D. PUSH-IN TEE SUPPLIED. (CONNECT TO FOUNTAIN SUPPLY LINE)



EQUIPMENT NO. REVISED PER BY: FV		MODEL(S)		1455 KLEPPLELANE	
DRAWN: JP	DATE: 09/14/17	CHKD: JC	SCALE: N/A	DRAWING TYPE: INSTALLATION	SIZE: A1 SHEET 6 OF 8
APPROVED: FV	DATE: 04/19/24	PART NUMBER: 0510000490.D		REVISION: 12	
SPARKS, NEVADA 89431			1455 KLEPPLELANE		
(775) 359-4712 FAX (775) 359-7424			SPARKS, NEVADA 89431		
E-MAIL: HAWS@HAWS.CO.COM			SPARKS, NEVADA 89431		
WEBSITE: WWW.HAWS.CO.COM			SPARKS, NEVADA 89431		
1920/1920HPS/1920W			SPARKS, NEVADA 89431		

6700 MOUNTING PLATE
(BEHIND FINISH WALL)
- OR -
6700R RETROFIT PLATE
(ON TOP OF FINISH WALL)

* MODELS 1920 (BOTTLE FILLER),
BP15, BP6 (BACK PANELS) AND
6468 (WASTE DRIP TRAY) ARE
ALL AVAILABLE TOGETHER AS
MODEL 1922.

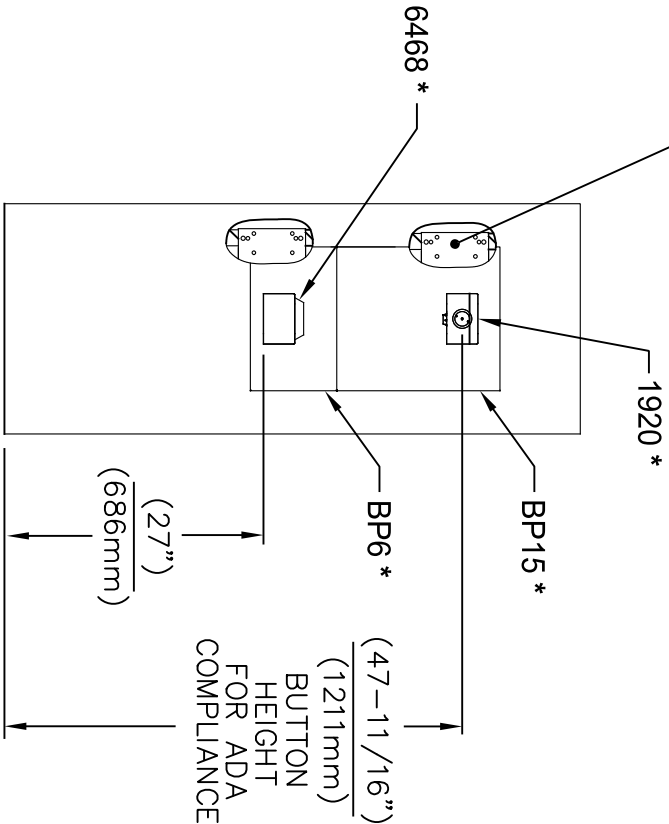

INSTALLATION ABOVE 6468

1. SEE SEPARATE INSTALLATION DRAWINGS FOR MOUNTING PLATE, WASTE DRIP TRAY AND BACK PANELS (SHOWN FOR REFERENCE - NOT SUPPLIED).
2. WHEN INSTALLING THIS UNIT, LOCAL, STATE OR FEDERAL CODES SHOULD BE ADHERED TO FOR INSTALLATION LOCATIONS, WASTE & SUPPLY REQUIREMENTS OTHER THAN SHOWN.

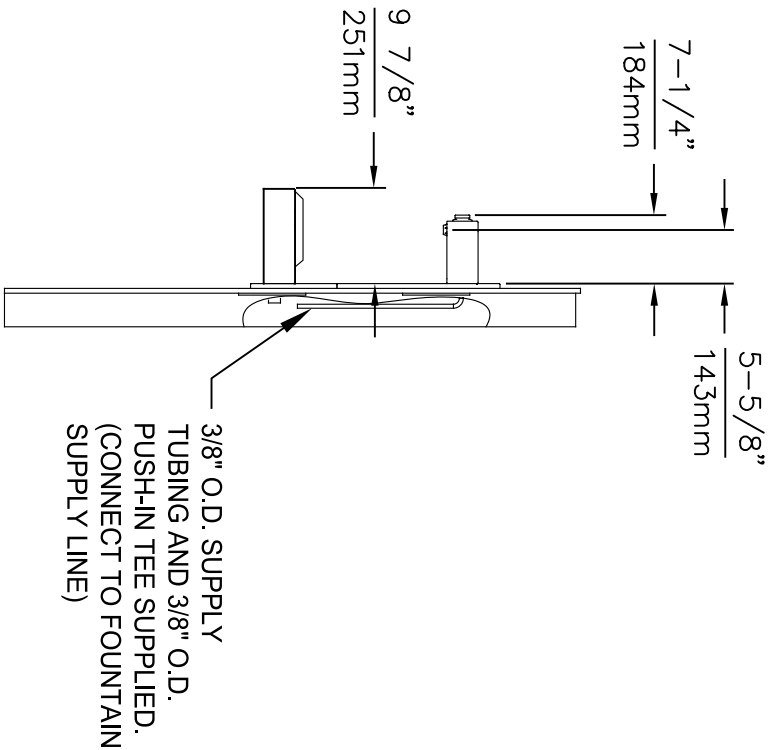

3/8" O.D. SUPPLY
TUBING AND 3/8" O.D.
PUSH-IN TEE SUPPLIED.
(CONNECT TO FOUNTAIN
SUPPLY LINE)



Since 1906

1455 KLEPPLELANE

SPARKS, NEVADA 89431

(775) 359-4712 FAX (775) 359-7424

E-MAIL: HAWS@HAWSCO.COM

WEBSITE: WWW.HAWSCO.COM

ECON. NO. REVISED PER BY: FV

DRAWN: ECON. 3972

DATE: 10/27/20

APPROVED: FV

MODEL(S)

1920/1920HPS/1920W

SCALE: N/A

DRAWING TYPE:

PART NUMBER

0510000490 D

REVISION: 12

SIZE: A1 SHEET: 7 OF 8

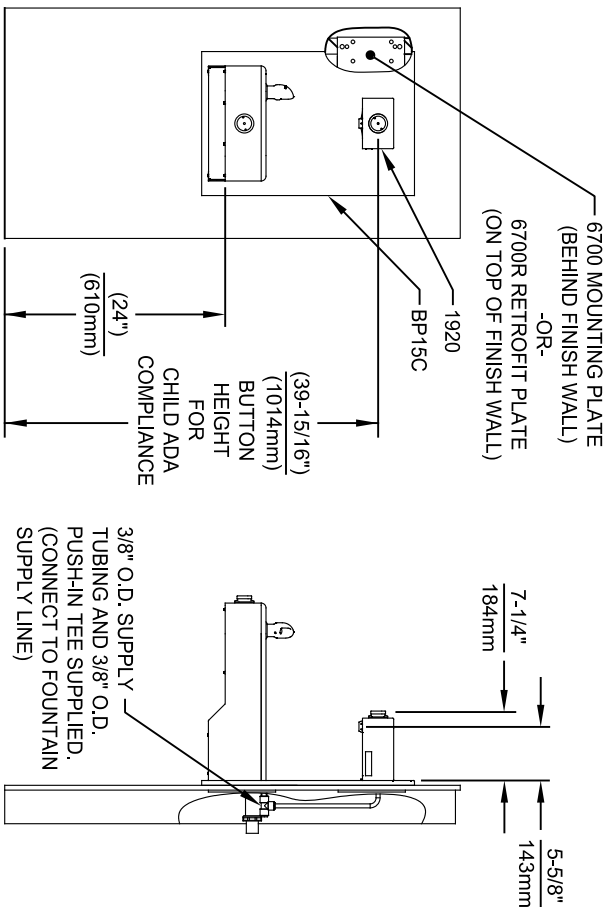

INSTALLATION ABOVE HAWS 1107L & H1107.8 SERIES

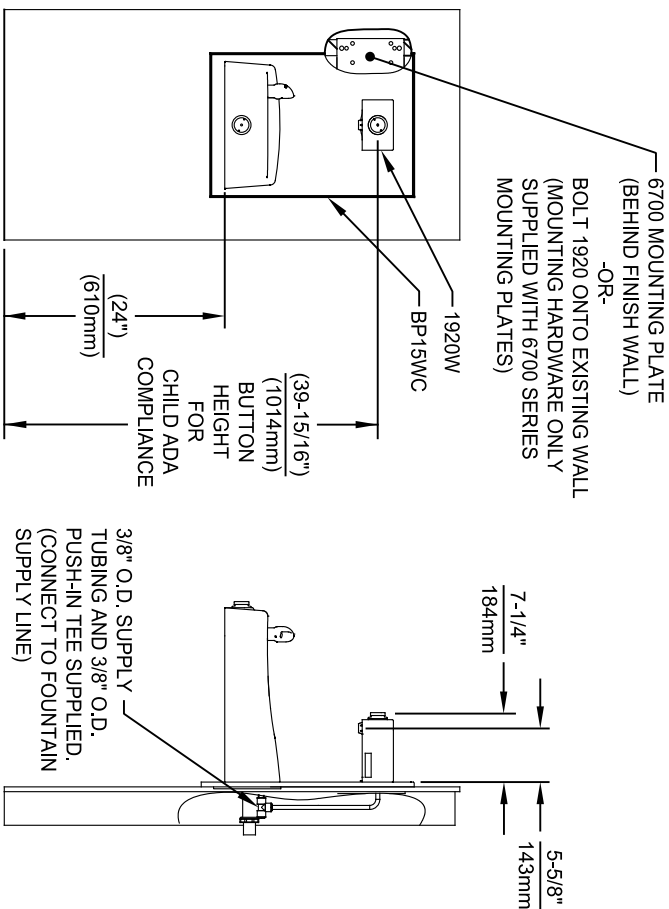

INSTALLATION ABOVE HAWS 1311

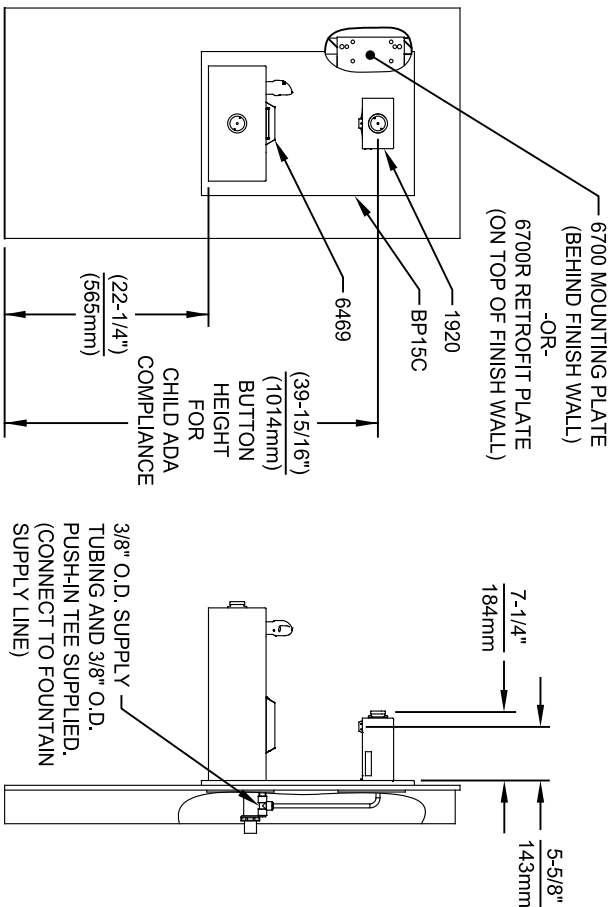

INSTALLATION ABOVE HAWS 1109, 1109.14 & H1109.8 SERIES

- NOTES:
1. HEIGHT DIMENSIONS SHOWN ARE FOR CHILD ADA APPLICATIONS:
- BOTTLE FILLER HEIGHT AT 40" MAX.
- DRINKING FOUNTAIN BUBBLER HEIGHT AT 30" MAX.
(SEE SHEETS 3, 4 & 5 FOR ADULT ADA HEIGHT DIMENSIONS)
 2. SEE SEPARATE INSTALLATION DRAWINGS FOR MOUNTING PLATES AND BACK PANELS (SHOWN FOR REFERENCE - NOT SUPPLIED).
 3. WHEN INSTALLING THIS UNIT, LOCAL, STATE OR FEDERAL CODES SHOULD BE ADHERED TO FOR INSTALLATION LOCATIONS, WASTE & SUPPLY REQUIREMENTS OTHER THAN SHOWN.

Haws
Since 1906

1455 KLEPPLELANE
SPARKS, NEVADA 89431
(775) 359-4712 FAX (775) 359-424
E-MAIL: HAWS@HAWSCO.COM
WEBSITE: WWW.HAWSCO.COM

ECN NO. REVISED PER BY:	MODEL(S)	SCALE:	DATE:	INSTALLATION:	SIZE:	SHEET:
9807	1920/1920HPS/1920W	N/A	04/19/24		A1	8 OF 8
DRAWN:	DATE:	CHK'D:	DATE:	REVISION:		
FV	01/26/24	JC		12		
APPROVED:	DATE:	SCALE:	N/A	DRAWING TYPE:		
FV	04/19/24					
PART NUMBER:	05110000490 D					

THIS DOCUMENT IS TRUE AND CORRECT AT TIME OF PUBLICATION. CONTAINED PRODUCT IMPROVEMENTS HAVE SPECIFICATIONS AND MEASUREMENTS SUBJECT TO CHANGE WITHOUT NOTICE.

DUAL FOUNTAIN
SHOWN FROM REAR

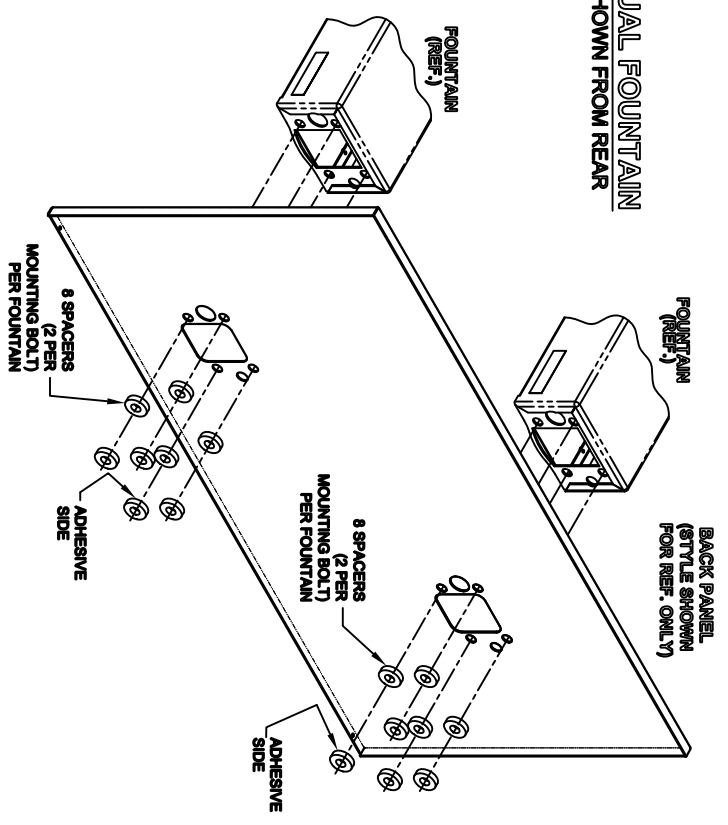

- NOTES:**
- 1 ON ALL BACK PANEL MODELS, SPACERS ARE NOT USED WHEN A MOUNTING FRAME IS USED EXCEPT AS SPECIFIED IN NOTE 2
 - 2 INDICATED SPACERS ARE USED WITH MOUNTING FRAME (DUAL ADJUSTABLE)

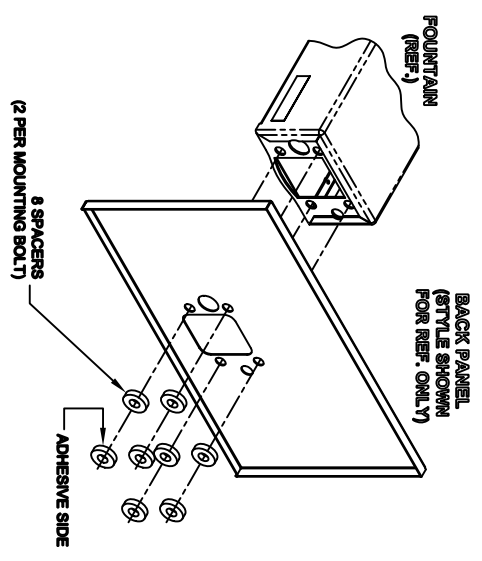

SINGLE FOUNTAIN
SHOWN FROM REAR

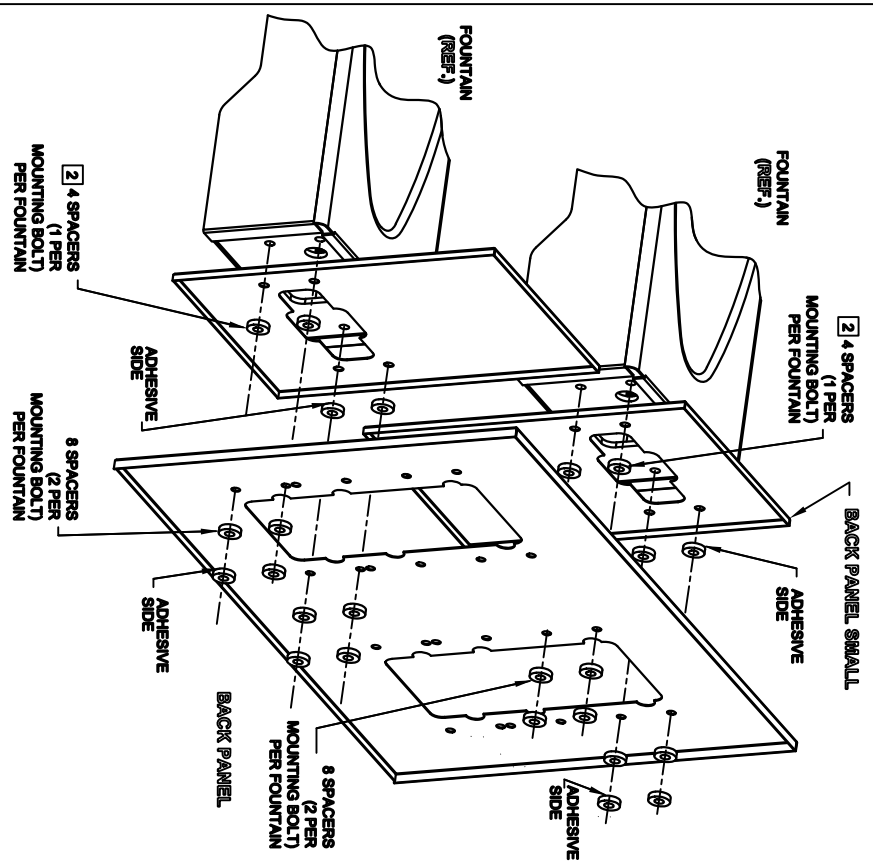

DUAL FOUNTAIN ADJUSTABLE
SHOWN FROM REAR



1465 KLEPPE LANE
SPARKS, NEVADA, 89431
(775) 399-4712 FAX (759) 399-7424
E-MAIL: HAWS@HAWS.CO.COM
WEBSITE: WWW.HAWS.CO.COM

ECN NO. REVISED PER BY:	MODEL(S)	BACK PANEL
DRAWN: []	DATE: []	SPACER INSTRUCTIONS
CHKD: []	DATE: []	INSTALLATION
APPROVED: []	DATE: []	SIZE: A
	SCALE: 1:10	DRAWING TYPE:
		SHEET: 1 OF 1
PART NUMBER:	0002082219	REV: 5

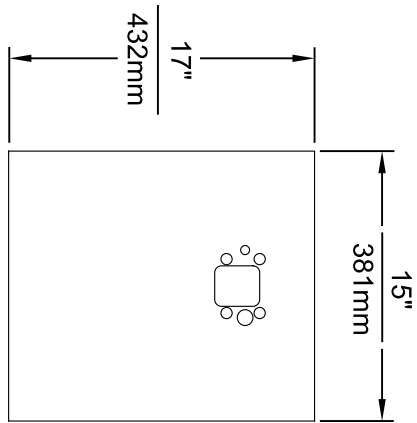

MODEL BP15 / BP15HPS / BP15W

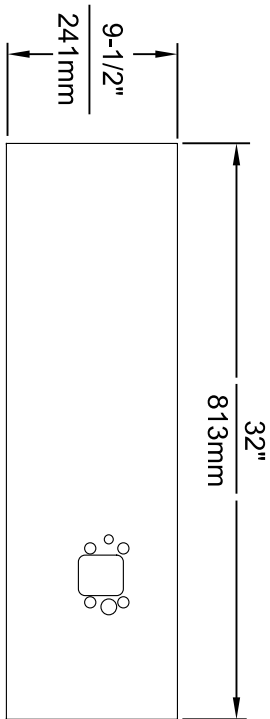
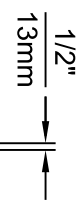

MODEL BP32 / BP32HPS / BP32W

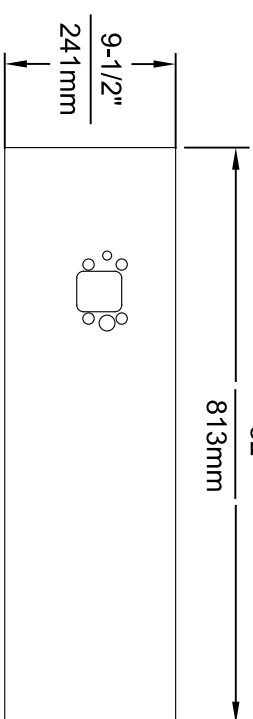
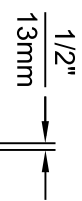

MODEL BP32R / BP32RW

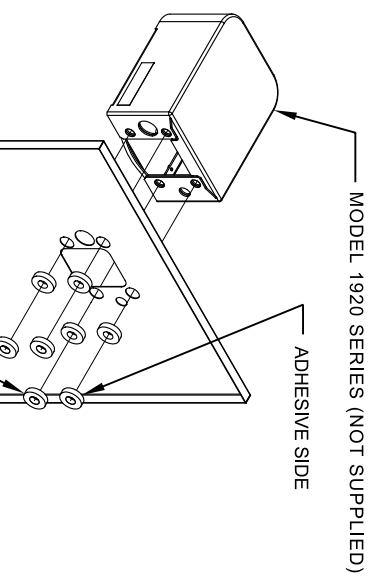
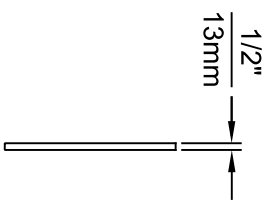

8 SPACERS (2 PER MOUNTING BOLT IF THE MOUNTING PLATE (MODEL 6700 - NOT SUPPLIED) IS INSTALLED BEHIND THE FINISHED WALL. USE 1 SPACER PER BOLT FOR RETROFITS WHERE THE MOUNTING PLATE (MODEL 6700R - NOT SUPPLIED) IS INSTALLED IN FRONT OF THE FINISHED WALL)

INSTALLATION OVER SINGLE FOUNTAIN

SHOWN FROM REAR
 (SEE SHEET 3 OF 3 FOR INSTALLATION OF SPACERS ON COMBINATION BOTTLE FILLER AND FOUNTAIN BACK PANELS FOR CHILD HEIGHT APPLICATIONS - MODELS BP15C & BP15WC)

- NOTES:
1. WHEN INSTALLING THIS UNIT, LOCAL, STATE OR FEDERAL CODES SHOULD BE ADHERED TO.
 2. BOTTLE FILLER SHOWN FOR REFERENCE ONLY (NOT SUPPLIED).

 <p>Haws Since 1906</p>		MODEL(S) DRAWING, BACK PANEL, SPACER INSTALLATION FOR BP15 SERIES & BP32 SERIES, BOTTLE FILLER	PART NUMBER 0510000493
EGN NO. REVISED PER BY: 5081 FV	DATE: 06/27/16 CHK'D: JC APP'D: FV	SCALE: 1"=1" DRAWING TYPE: INSTALLATION	REVISION: 5
SPARKS, NEVADA 89431 (775) 359-4712 FAX (775) 359-7424 E-MAIL: HAWS@HAWSCO.COM WEBSITE: WWW.HAWSCO.COM		1455 KLEPPLELANE	SIZE: A1 SHEET: 1 OF 3

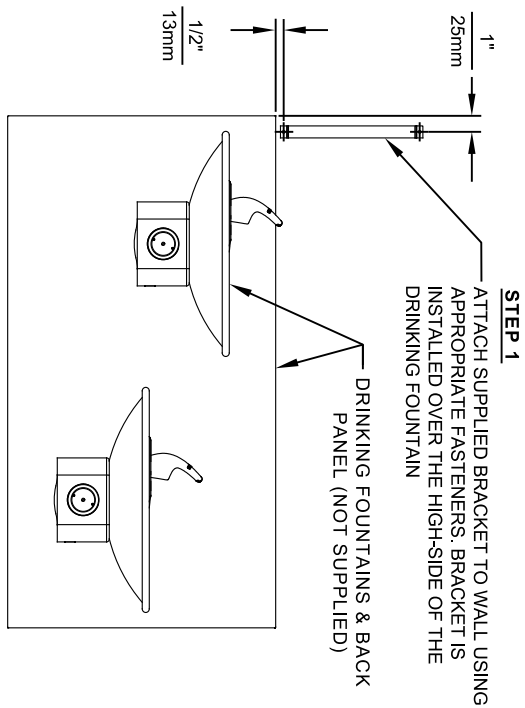

STEP 2
PLACE THE BACKPLATE AGAINST THE WALL AND SLIDE SIDEWAYS SO THE TABS CATCH UNDER THE BRACKET.

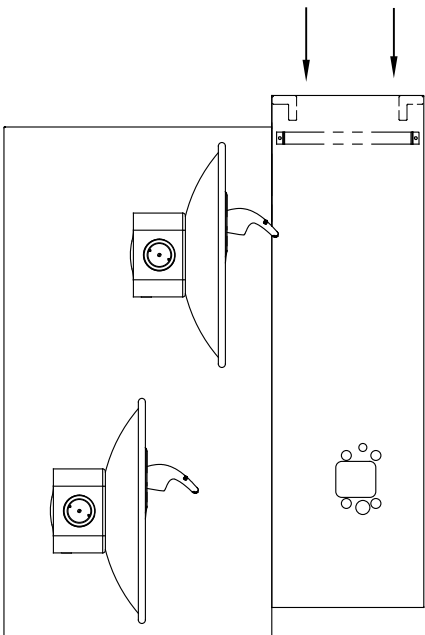

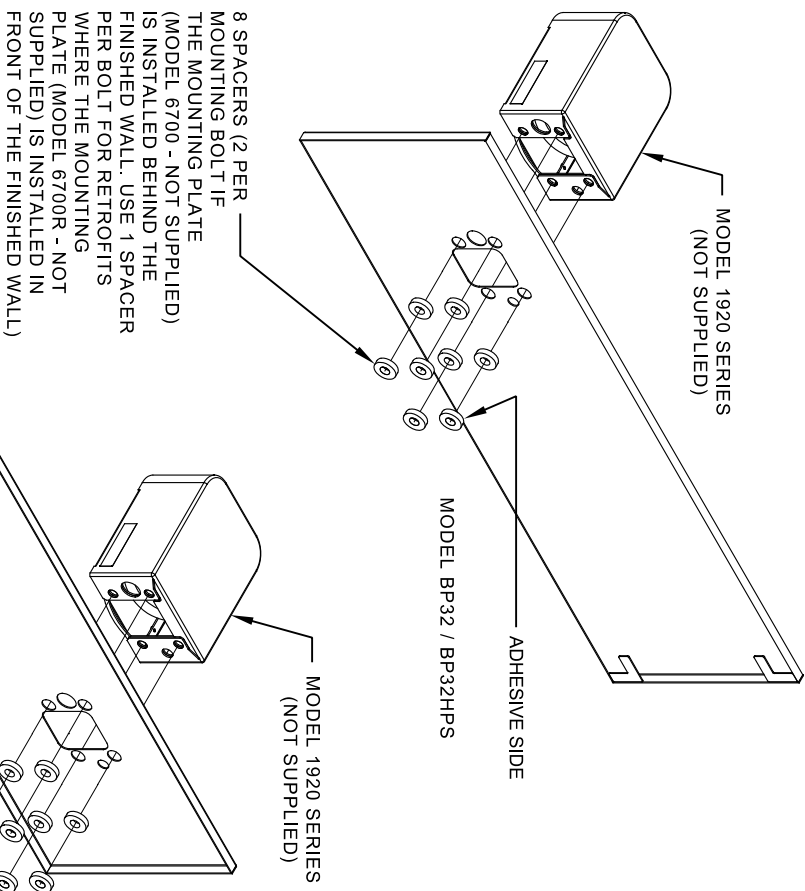

STEP 3
INSTALL THE BOTTLE FILLER (NOT SUPPLIED) PER THE INSTRUCTIONS SUPPLIED WITH THE UNIT.

- NOTES:
1. WHEN INSTALLING THIS UNIT, LOCAL, STATE OR FEDERAL CODES SHOULD BE ADHERED TO.
 2. BOTTLE FILLERS, DRINKING FOUNTAINS & DRINKING FOUNTAIN BACK PANELS SHOWN FOR REFERENCE ONLY (NOT SUPPLIED).

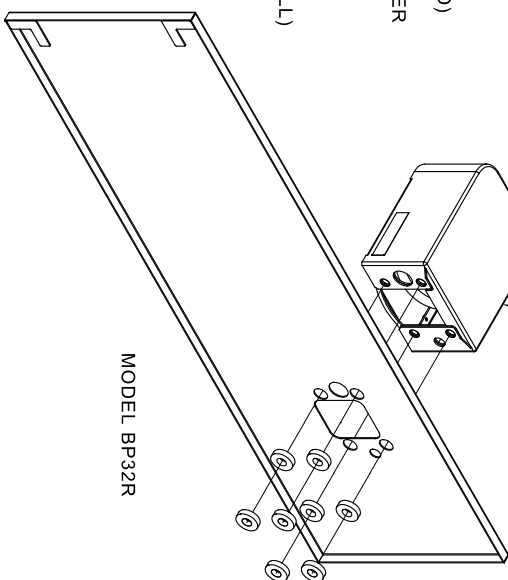

INSTALLATION OVER DOUBLE FOUNTAIN SHOWN FROM REAR



		MODEL(S) DRAWING, BACK PANEL, SPACER INSTALLATION FOR BP15 SERIES & BP32 SERIES, BOTTLE FILLER	
EGN NO. REVISED PER BY:	5081 FV	SCALE:	1:1
DRAWN:	ECN: 3972	DATE:	02/02/17
CHKD:	JC	DATE:	04/19/24
APPROVED:	FV	SCALE:	1:1
1455 KLEPPLELANE SPARKS, NEVADA 89431 (775) 359-4712 FAX (775) 359-7424 E-MAIL: HAWS@HAWSCO.COM WEBSITE: WWW.HAWSCO.COM		Since 1906	PART NUMBER 0510000493 REVISION 5
INSTALLATION		SIZE: A1	SHEET: 2 OF 3

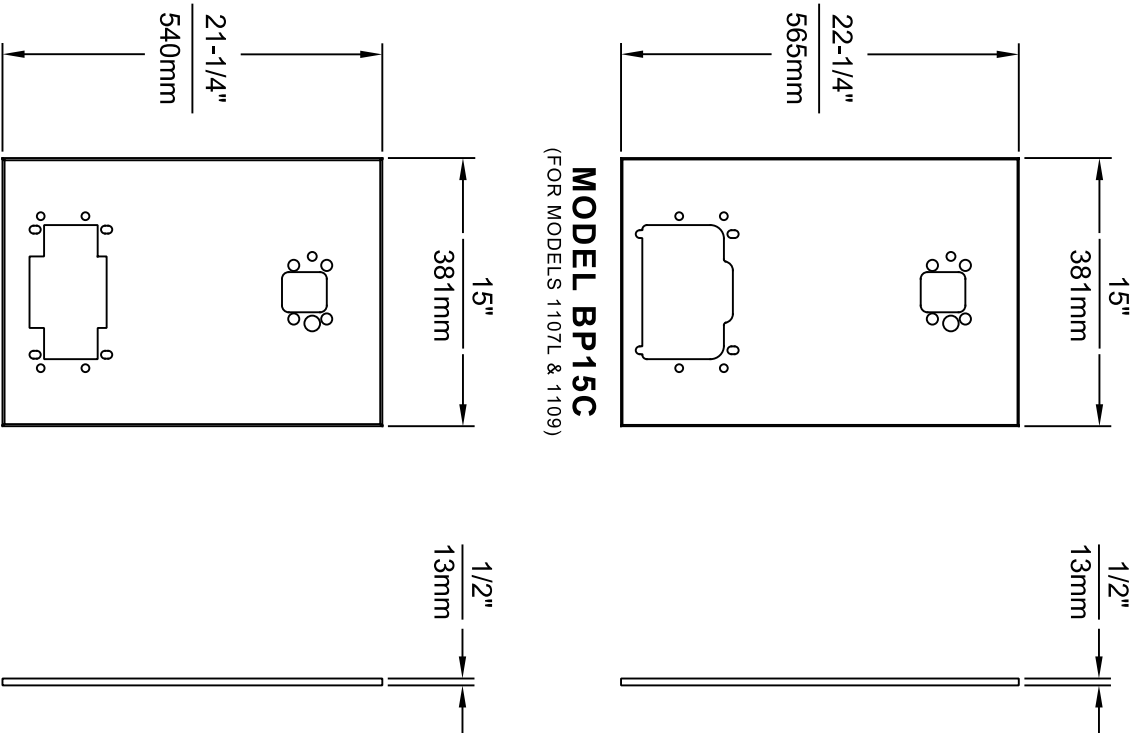

MODEL BP15WC
(FOR MODEL 1311)

- NOTES:
1. WHEN INSTALLING THIS UNIT, LOCAL, STATE OR FEDERAL CODES SHOULD BE ADHERED TO.
 2. BOTTLE FILLER AND DRINKING FOUNTAIN SHOWN FOR REFERENCE ONLY (NOT SUPPLIED).

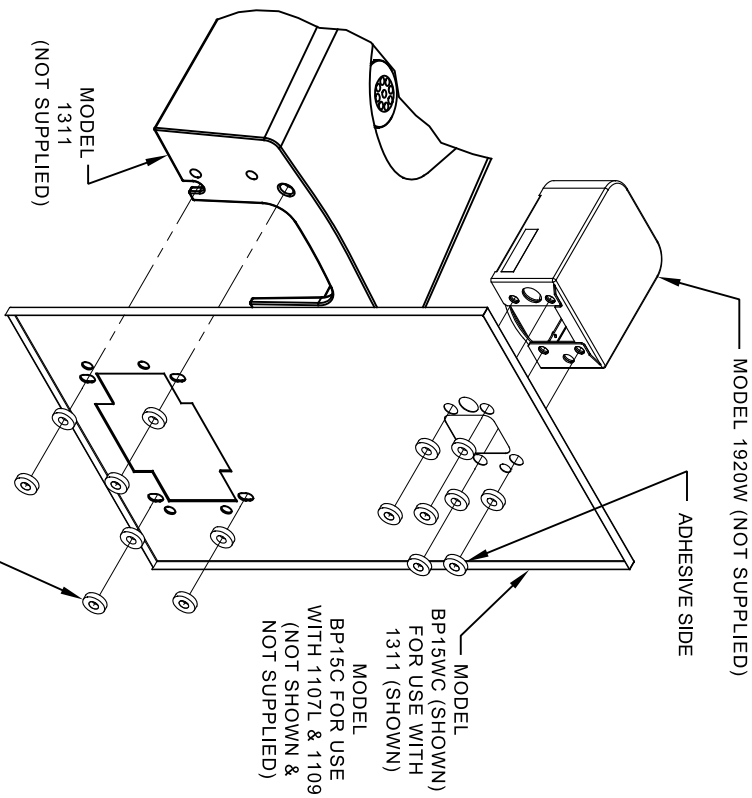

16 SPACERS (2 PER MOUNTING BOLT IF BOTH MOUNTING PLATES (MODEL 6700 - NOT SUPPLIED) ARE INSTALLED BEHIND THE FINISHED WALL. USE 1 SPACER PER BOLT FOR RETROFITS WHERE BOTH MOUNTING PLATES (MODEL 6700R - NOT SUPPLIED) ARE INSTALLED IN FRONT OF THE FINISHED WALL)

ONE PIECE INSTALLATION ON SINGLE FOUNTAIN

SHOWN FROM REAR

(MODEL BP15C & BP15WC ARE COMBINATION BOTTLE FILLER AND FOUNTAIN BACK PANELS USED FOR CHILD HEIGHT APPLICATIONS ONLY ON MODELS 1107L, 1109 & 1311 - BOTTLE FILLER & DRINKING FOUNTAIN NOT SUPPLIED)

 <p>Haws Since 1906</p>		<p>1455 KLEPPLELANE SPARKS, NEVADA 89431 (775) 359-4712 FAX (775) 359-424 E-MAIL: HAWS@HAWSCO.COM WEBSITE: WWW.HAWSCO.COM</p>	
<p>ECON. NO. 5972 REVISED PER BY: FV DATE: 12/19/23</p>	<p>MODEL(S) DRAWING, BACK PANEL, SPACER INSTALLATION FOR BP15 SERIES & BP32 SERIES, BOTTLE FILLER</p>	<p>SCALE: 1:1 DRAWING TYPE: INSTALLATION</p>	<p>PART NUMBER: 0510000493 REVISION: 5</p>
<p>APPROVED: FV DATE: 04/19/24</p>	<p>DATE: 04/19/24</p>	<p>SIZE: A1 SHEET: 3 OF 3</p>	

6700 INDEX

INSTALLATION WITH:	TYPICAL USES	SEE SHEET...
GENERAL INSTALLATION		IMPORTANT INFORMATION FOR ALL INSTALLATIONS
1001 BOWLS	HAWS SERIES 1001X, H1001.8X	3 OF 6
1107 BOWLS	HAWS SERIES 1107L, H1107.8	3 OF 6
1109 BOWLS	HAWS SERIES 1109X, H1109.8X	3 OF 6
1047 BOWLS	HAWS SERIES 1047	4 OF 6
1011 BOWLS	HAWS SERIES 1011X, H1011.8X	4 OF 6
1119 BOWLS	HAWS SERIES 1119X, H1119.8X	4 OF 6
1117 BOWLS	HAWS SERIES 1117X, H1117.8X	5 OF 6
1311 BOWLS	HAWS SERIES 1311	5 OF 6
1501 BOWLS	HAWS SERIES 1501	5 OF 6
CHILD HEIGHT	HAWS 1107PCH, 1109PCH, 1311PCH	6 OF 6



Haws
Since 1906

1455 KLEPPE LANE
SPARKS, NEVADA 89431
(775) 359-4712 FAX (775) 359-7424
E-MAIL: HAWS@HAWS.CO.COM
WEBSITE: WWW.HAWS.CO.COM

ECON NO. REVISED PER BY:		MODEL(S)		PART NUMBER	
CON. 6131	JG	67/00		0002080016	
DATE: 10/03/24	CHKD: JG			REVISION	
APPROVED: RH	DATE: 11/26/24	SCALE: N/A	DRAWING TYPE:	INSTALLATION:	SHEET: 1 OF 6

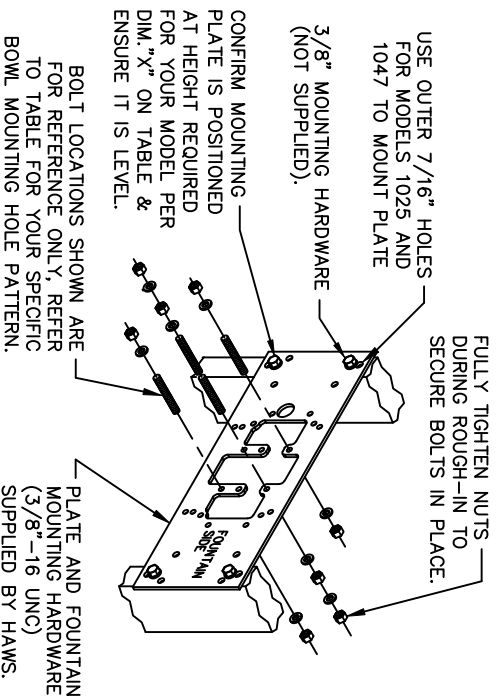
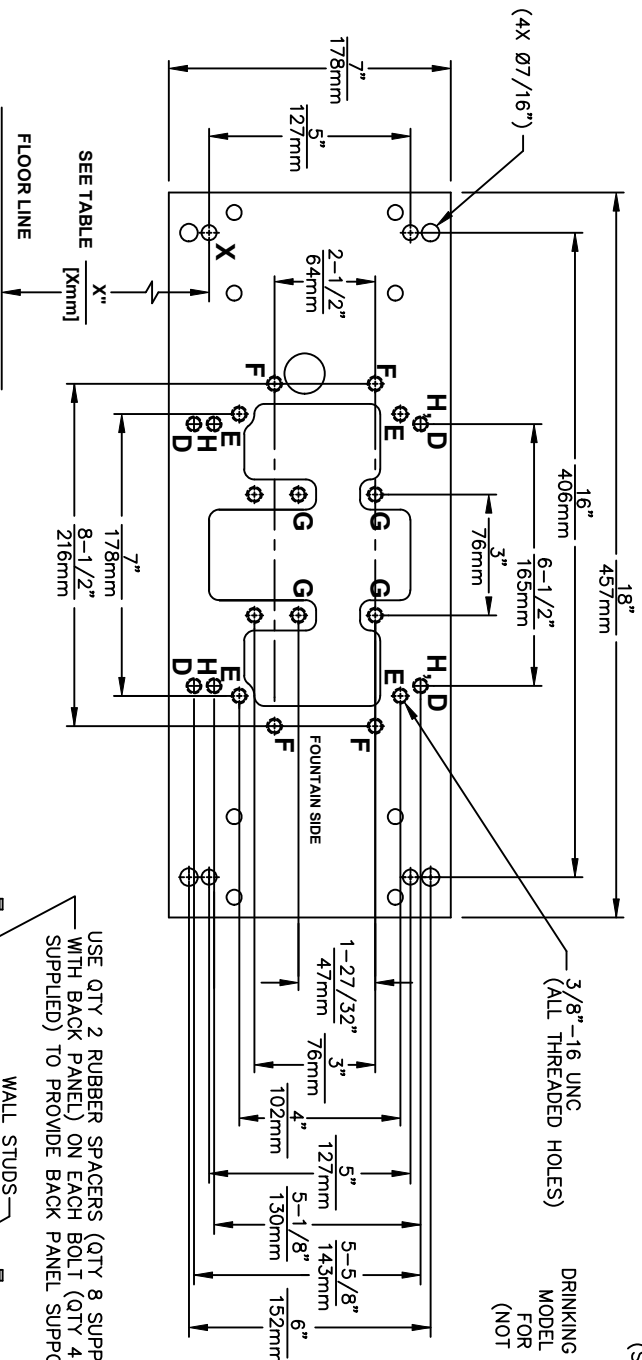

CAUTION

REGARDING CONCRETE/MASONRY WALL MOUNTING: DO NOT SECURE MOUNTING PLATE TO SAME SIDE OF WALL AS FOUNTAIN. AVOID COMPROMISING INTEGRITY OF WALL WHEN ANCHORING FOUNTAIN. IT IS RECOMMENDED THAT INSTALLER CALL TECHNICAL SUPPORT IF THERE ARE ANY QUESTIONS AS TO HOW TO OBTAIN A PROPER ANCHOR IN CONCRETE/MASONRY WALLS. 1-800-766-5612

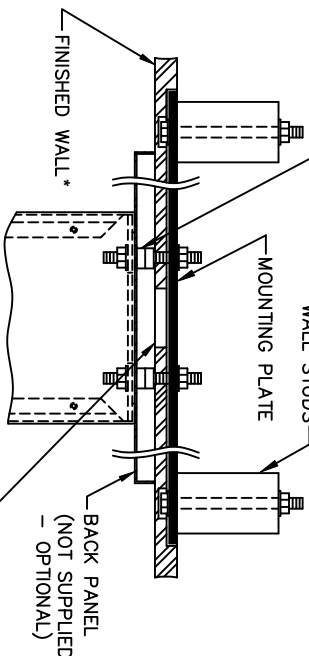

TOP VIEW

USE QTY 2 RUBBER SPACERS (QTY 8 SUPPLIED WITH BACK PANEL) ON EACH BOLT (QTY 4 SUPPLIED) TO PROVIDE BACK PANEL SUPPORT.

6700 MOUNTING PLATE
FOR USE WITH
DRINKING FOUNTAINS
AND WASTE DRIP TRAYS
AT 27" ADULT HEIGHT
(SEE SHEETS 2 - 5 FOR USE WITH
BOTTLE FILLER 1920/1920HO SERIES
AND CHILD HEIGHT APPLICATIONS)

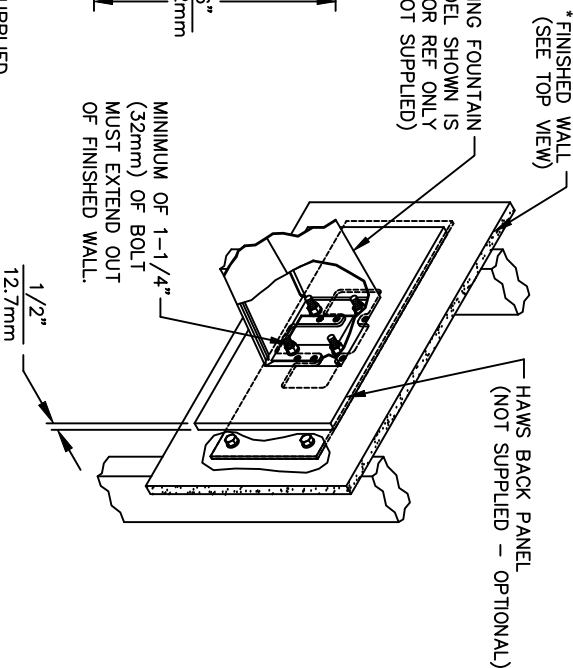

MODEL	USE BOWL MTG. HOLE PATTERN	USE "X" DIM. BELOW TO POSITION MOUNTING PLATE HOLE "X"
1001	"G"	25-3/8" [645mm]
1025	"D"	28-1/8" [714mm]
1047	"E"	24-3/8" [619mm]
1105	"H"	34-5/16" [872mm]
1107L	"F"	26-3/16" [665mm]
1109	"H"	27-5/16" [694mm]
1109.14	"H"	27-5/16" [694mm]
1109FR	"H"	27-5/16" [694mm]
1311	"E"	26-3/4" [679mm]

MODEL	WASTE DRIP TRAY (ONLY) AT 27" ADULT HEIGHT
6468	"G"
1922	"G"

* FINISH WALL OVER MOUNTING PLATE AND BEHIND BACK PANEL. MAKE SURE THAT FINISHED WALL EXTENDS WITHIN THE BRACKET/BOWL MOUNTING HOLES (TO PROVIDE SURFACE AREA FOR RUBBER SPACERS TO CONTACT).

1455 KLEPPE LANE
 SPARKS, NEVADA, 89431
 (775) 359-4712 FAX (775) 359-7424
 E-MAIL: HAWS@HAWS.CO.COM
 WEBSITE: WWW.HAWS.CO.COM

ECN NO. REVISED PER BY:	MODEL(S)
DRAWN: C.L.	6700
DATE: 09-03-03	
CHKD: J.G.	
DATE:	
APPROVED: RH	SCALE: N/A
DATE: 11/26/24	DRAWING TYPE: INSTALLATION
	SIZE: A
	SHEET: 2 OF 6
	REVISION: 25

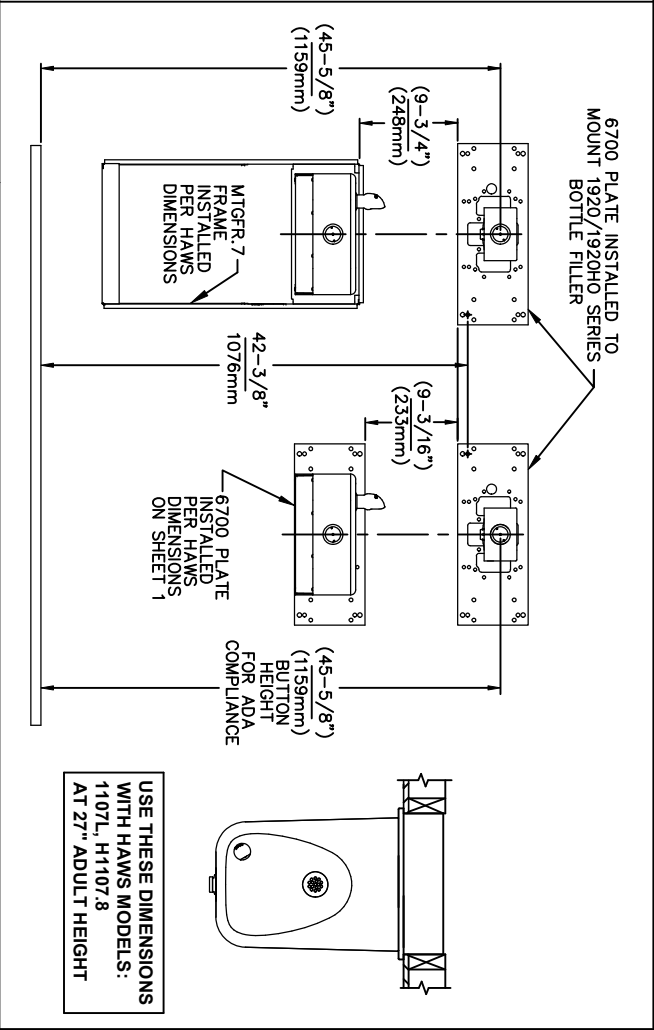
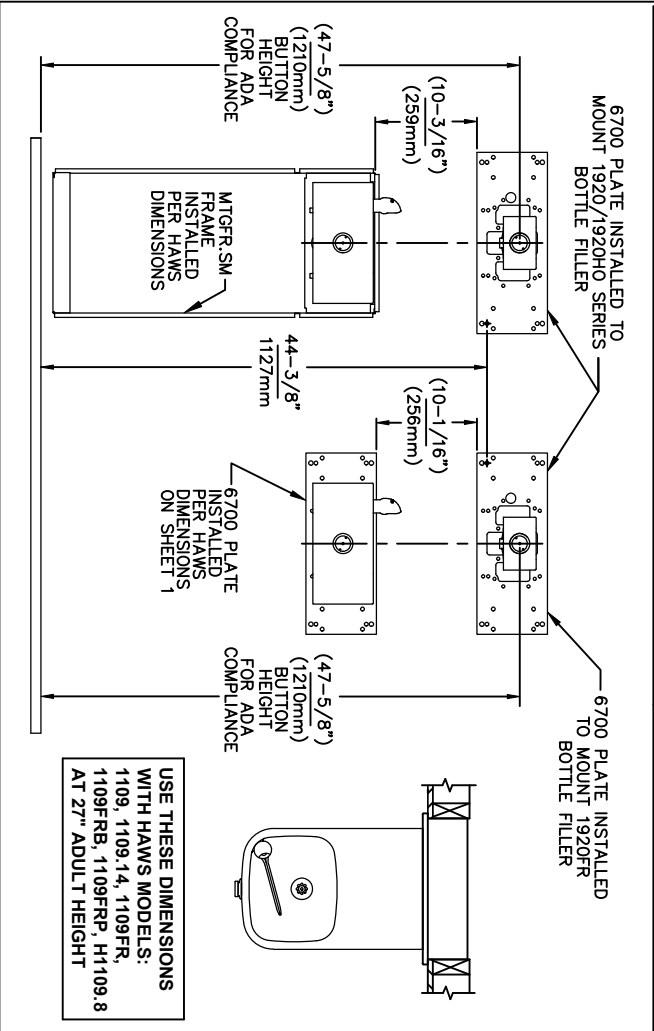
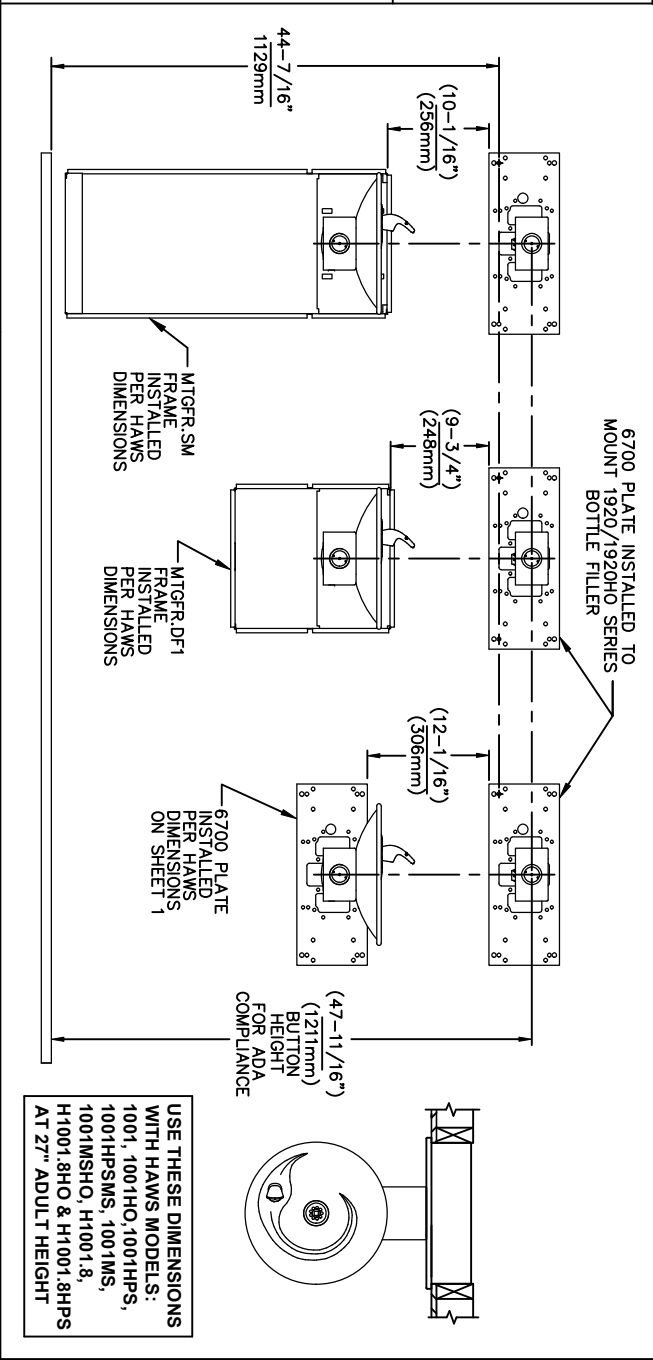
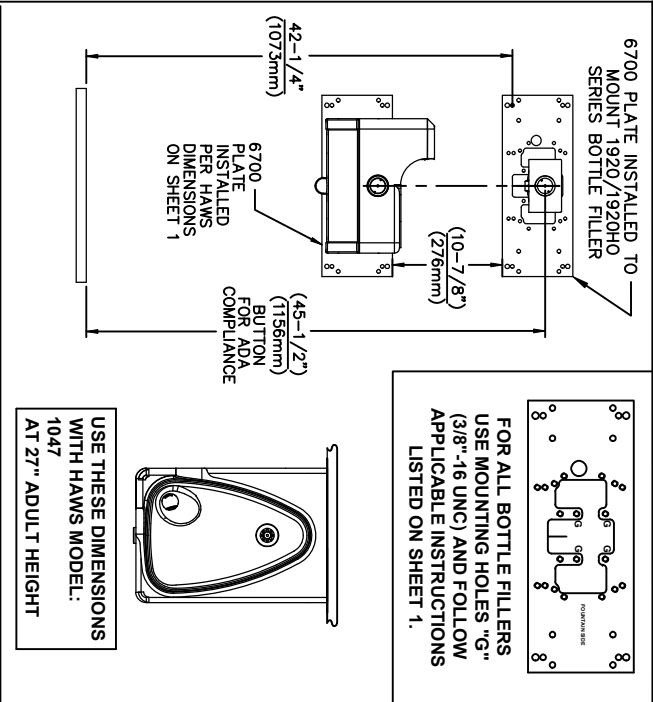

NOTES:
 1. WHEN INSTALLING THIS UNIT, LOCAL, STATE OR FEDERAL CODES SHOULD BE ADHERED TO.
 2. BACK PANELS (OPTIONAL) NOT SHOWN FOR CLARITY.

6700 MOUNTING PLATE
 FOR USE WITH BOTTLE FILLER
 (SEE SHEET 1 FOR USE WITH
 DRINKING FOUNTAINS)

1455 KLEPPE LANE
 SPARKS, NEVADA, 89431
 (775) 359-4712 FAX (775) 359-7424
 E-MAIL: HAWS@HAWS.CO.COM
 WEBSITE: WWW.HAWS.CO.COM

Since 1906

ECN NO.	REVISED PER BY:	MODEL(S)
0002080016	EV	67/00
DATE:	CHKD:	
02/09/17	JG	
DRAWN:	DATE:	
MJ	11/26/24	
APPROVED:	SCALE:	DRAWING TYPE:
RH	N/A	INSTALLATION
	SIZE:	SHEET:
	A	3 OF 6
		25

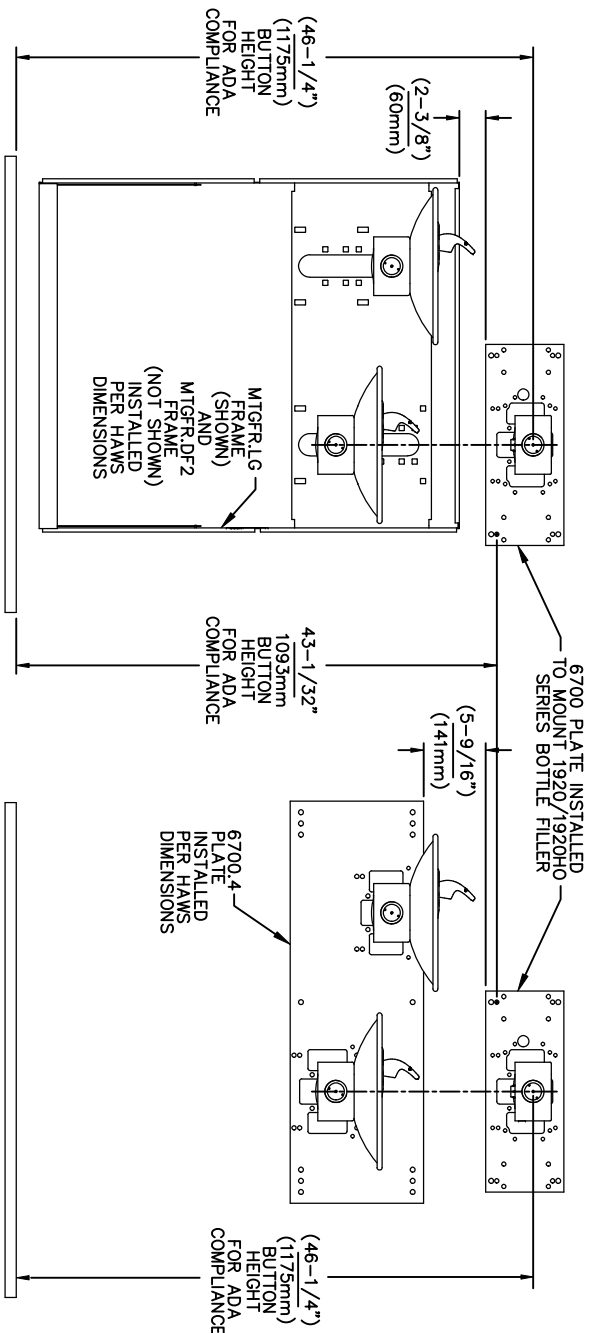

USE THESE MOUNTING DIMENSIONS IF INSTALLING OVER HAWS FOUNTAIN
 MODEL: 1011, 1011HO, 1011HO2, 1011HPS, 1011HPSHO, 1011HPSHO2, 1011HPSMS, 1011HMS, 1011HMSHO, 1011HMSHO2, H1011.8, H1011.8HO, H1011.8HO2 & H1011.8HPSM AT 27" ADULT HEIGHT
 INSTALL THE 6700 ABOVE THE FOUNTAIN MOUNTING PLATE OR FRAME AT THE DIMENSION SHOWN FOR CORRECT BACKPANEL SPACING
 BACK PANELS FOR BOTTLE FILLERS (NOT SUPPLIED - OPTIONAL) ARE NOT SHOWN FOR CLARITY.

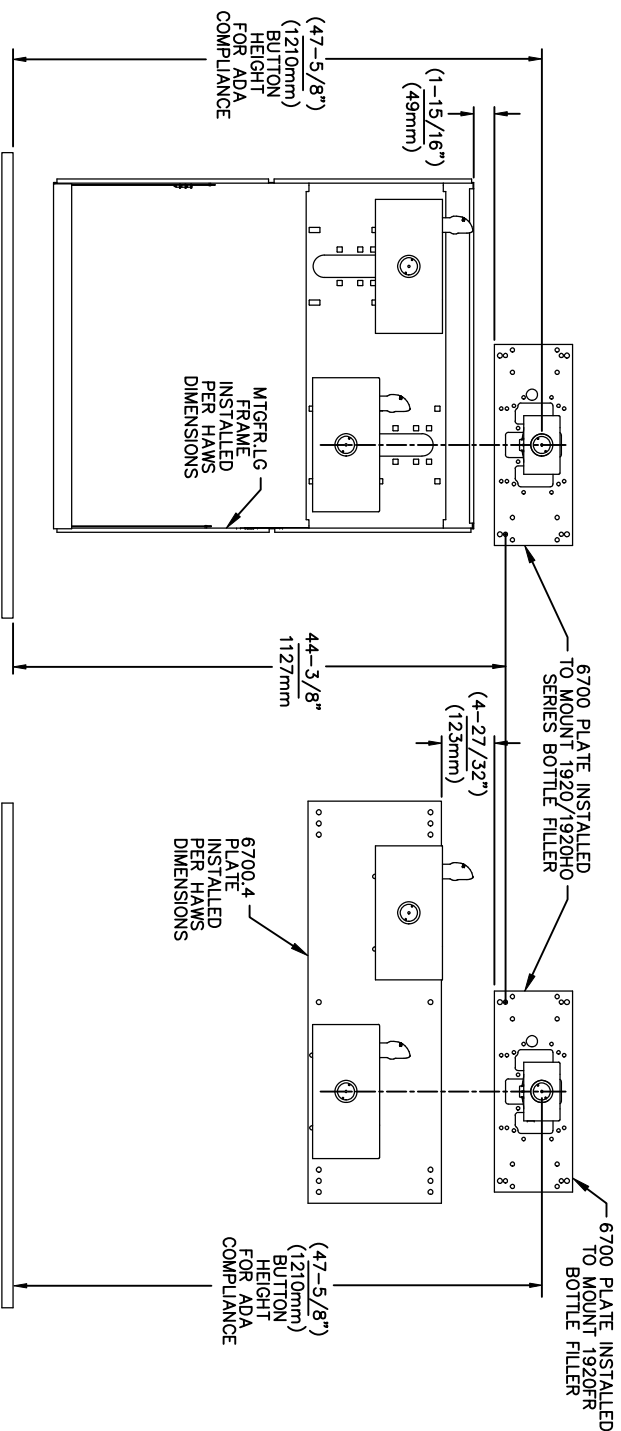
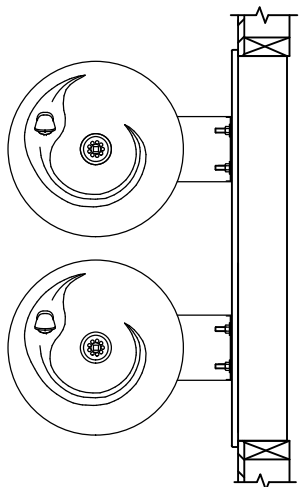

USE THESE MOUNTING DIMENSIONS IF INSTALLING OVER HAWS FOUNTAIN
 MODEL: 1119, 1119.14, 1119.14HO, 1119.14HO2, 1119FR, 1119FRB, 1119FRP, 1119HO, 1119HO2 & H1119.8 AT 27" ADULT HEIGHT
 INSTALL THE 6700 ABOVE THE FOUNTAIN MOUNTING PLATE OR FRAME AT THE DIMENSION SHOWN FOR CORRECT BACKPANEL SPACING
 BACK PANELS FOR BOTTLE FILLERS (NOT SUPPLIED - OPTIONAL) ARE NOT SHOWN FOR CLARITY.

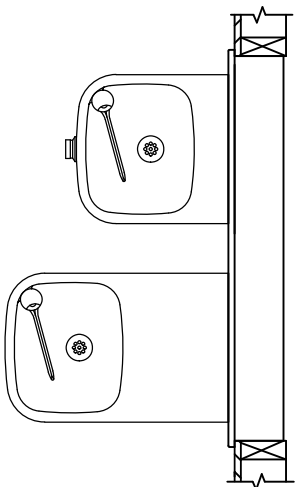

- NOTES:
- WHEN INSTALLING THIS UNIT, LOCAL, STATE OR FEDERAL CODES SHOULD BE ADHERED TO.
 - BACK PANELS (OPTIONAL) NOT SHOWN FOR CLARITY.

6700 MOUNTING PLATE
 FOR USE WITH BOTTLE FILLER
 (SEE SHEET 1 FOR USE WITH
 DRINKING FOUNTAINS)

Since 1906

1458 KLEPPE LANE
 SPARKS, NEVADA 89431
 (775) 359-4712 FAX (775) 359-7424
 E-MAIL: HAWS@HAWSCO.COM
 WEBSITE: WWW.HAWSCO.COM

ECN NO. REVISED PERBY:	MODEL(S)	6700	PART NUMBER
5550	6700		0002080016
DATE: 05/14/20	DATE: 05/14/20	SCALE: 1:13	REVISION: 25
CHKD: JS	DATE: 11/28/24	SCALE: 1:13	REVISION: 25
APPROVED: RH	DATE: 11/28/24	SCALE: 1:13	REVISION: 25
DRAWING TYPE: INSTALLATION		SIZE: A	SHEET: 4 OF 6

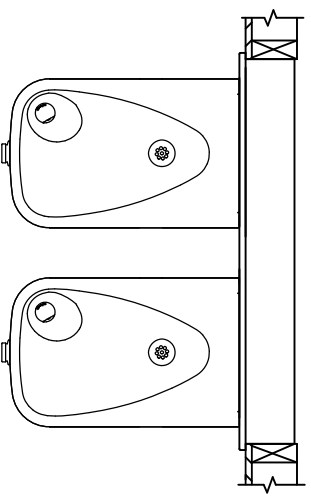
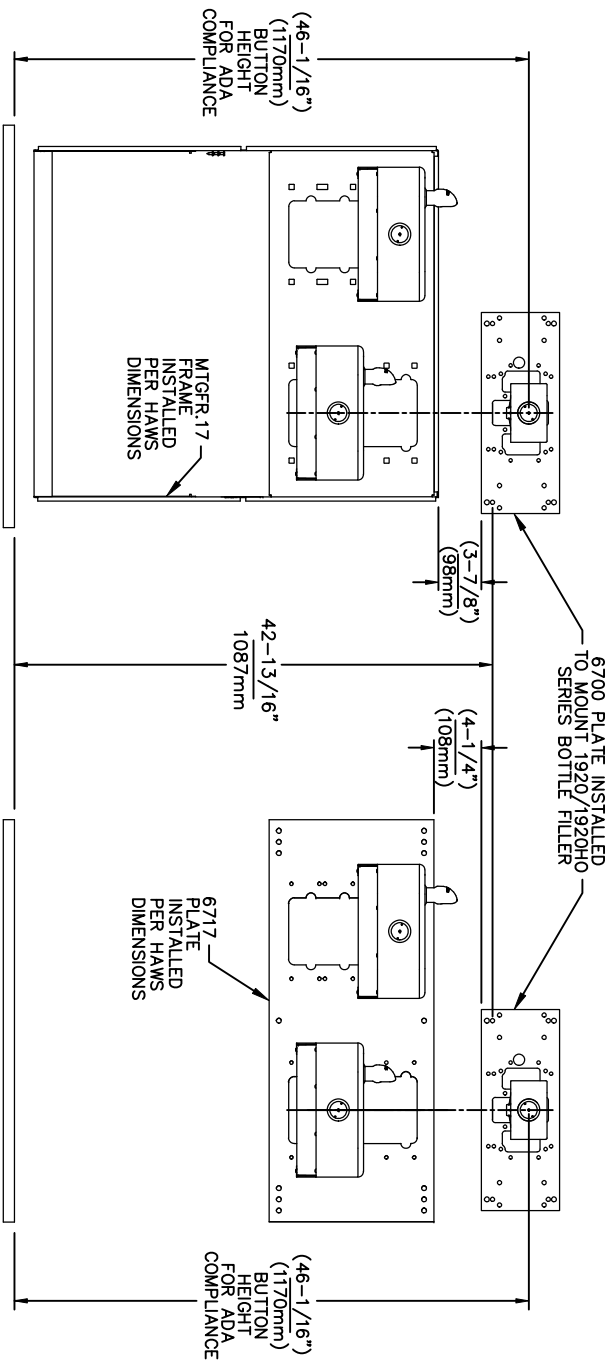

USE THESE MOUNTING DIMENSIONS IF INSTALLING OVER HAWS FOUNTAIN MODEL: 1117L, 1117LHO, 1117LHO2, H1117.8, H1117.8HO, H1117.8HO2, H1117LN, 1117LNHO, 1117LNHO2 AND H1117LN.8 USE A 6700.4 MOUNTING PLATE & NOT SHOWN - SEE MANUAL(S) AT 27" ADULT HEIGHT
 INSTALL THE 6700 ABOVE THE FOUNTAIN MOUNTING PLATE OR FRAME AT THE DIMENSION SHOWN FOR CORRECT BACKPANEL SPACING
 BACK PANELS FOR BOTTLE FILLERS (NOT SUPPLIED - OPTIONAL) ARE NOT SHOWN FOR CLARITY.

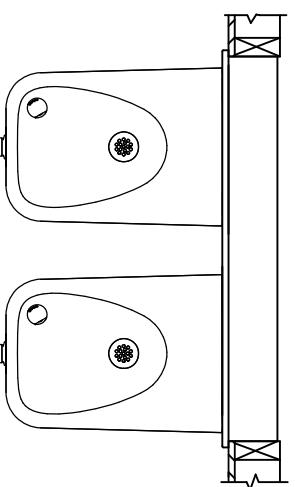
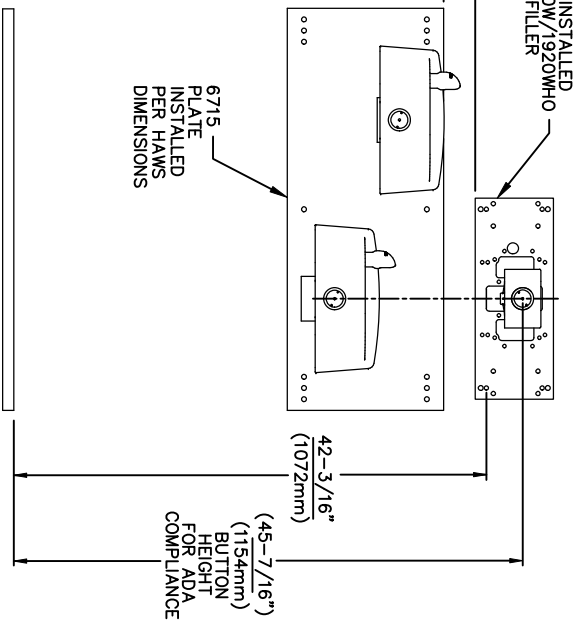
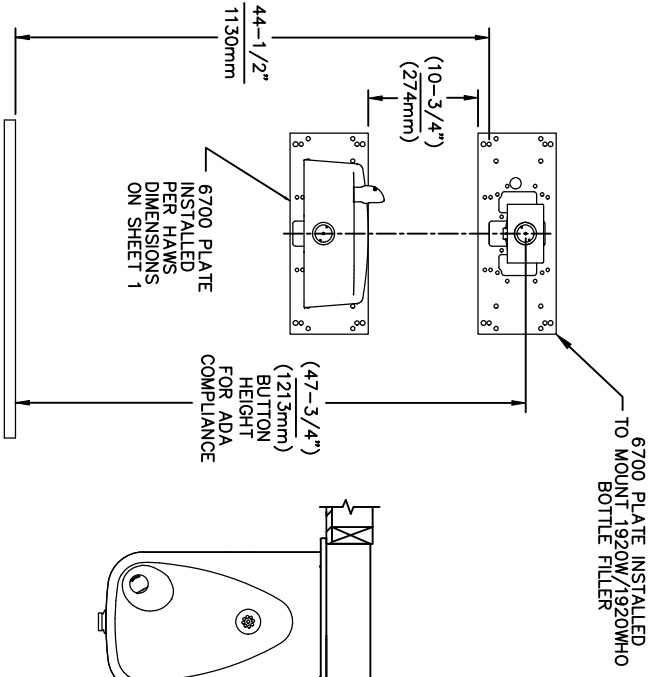

USE THESE MOUNTING DIMENSIONS IF INSTALLING OVER HAWS FOUNTAIN MODEL: 1311, 1501
 INSTALL THE 6700 ABOVE THE FOUNTAIN MOUNTING PLATE AT THE DIMENSION SHOWN FOR CORRECT BACKPANEL SPACING (IF APPLICABLE).
 BACK PANEL FOR BOTTLE FILLER (NOT SUPPLIED - OPTIONAL) IS NOT SHOWN FOR CLARITY.

- NOTES:
 1. WHEN INSTALLING THIS UNIT, LOCAL, STATE OR FEDERAL CODES SHOULD BE ADHERED TO.
 2. BACK PANELS (OPTIONAL) NOT SHOWN FOR CLARITY.

6700 MOUNTING PLATE
 FOR USE WITH BOTTLE FILLER
 (SEE SHEET 1 FOR USE WITH
 DRINKING FOUNTAINS)

Haws
 Since 1906

1458 KLEPPE LANE
 SPARKS, NEVADA, 89431
 (775) 359-4712 FAX (775) 359-7424
 E-MAIL: HAWS@HAWSCO.COM
 WEBSITE: WWW.HAWSCO.COM

ECN NO. REVISED PER BY:	MODEL(S)
5550	6700
DATE: 05/14/20	DATE: 05/14/20
CHKD: JS	CHKD: JS
APPROVED: RH	SCALE: 1:13
DATE: 11/28/24	DRAWING TYPE: INSTALLATION
	SIZE: A
	SHEET 5 OF 6

PART NUMBER	6700
REVISION	0002080016
	25

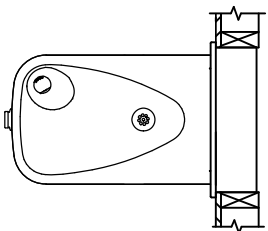
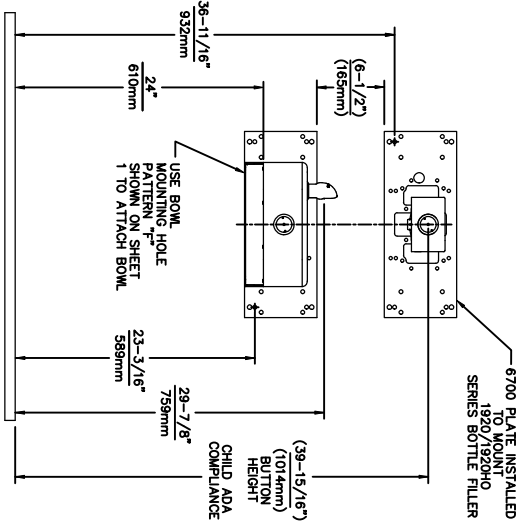

USE THESE DIMENSIONS WITH HAWMS
MODEL:
1107L
AT 24" CHILD HEIGHT *

6700 MOUNTING PLATE
FOR USE WITH BOTTLE FILLER AT
40" MAX. AND
DRINKING FOUNTAIN
AT 24" AND BUBBLER HEIGHT AT 30"
MAX. FOR CHILD ADA HEIGHT
(SEE SHEETS 1 & 2 FOR USE WITH
DRINKING FOUNTAIN AT 27" ADULT
HEIGHT DIMENSIONS)

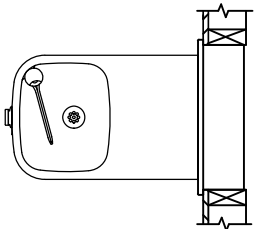
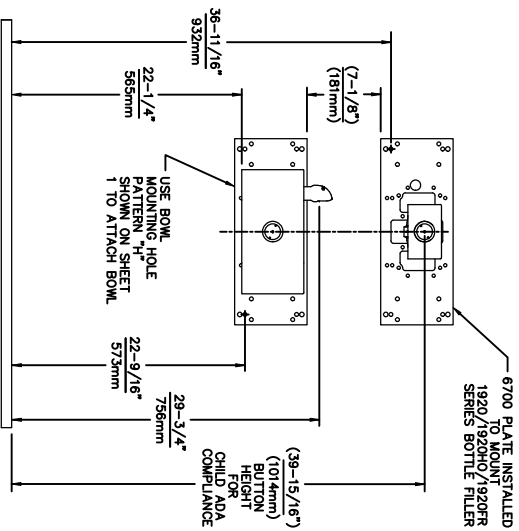

USE THESE DIMENSIONS WITH HAWMS
MODELS:
1109, 1109.14, 1109FR, 1109FRB, 1109FRP
AT 22-1/4" HEIGHT TO ACHIEVE 30" MAX.
CHILD ADA BUBBLER HEIGHT * NOTE:
MUST USE PARALLEL APPROACH WITH
THIS BOWL COMBINATION.

NOTES:
1. WHEN INSTALLING THIS UNIT, LOCAL, STATE
OR FEDERAL CODES SHOULD BE ADHERED TO.
2. ONE PIECE BACK PANELS BP15C (FOR USE WITH MODELS 1107L,
1109 SERIES & BOTTLE FILLER) & BP15WC (FOR USE WITH MODEL
1311 & BOTTLE FILLER) ARE USED FOR CHILD HEIGHT APPLICATIONS
AND ARE OPTIONAL (NOT SHOWN FOR CLARITY).

©2024 Haws Corporation - All Rights Reserved. HAWMS® and other trademarks used in these materials are the exclusive property of Haws Corporation.

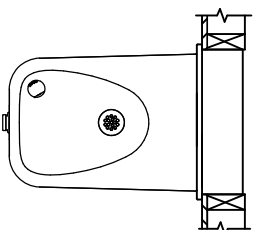
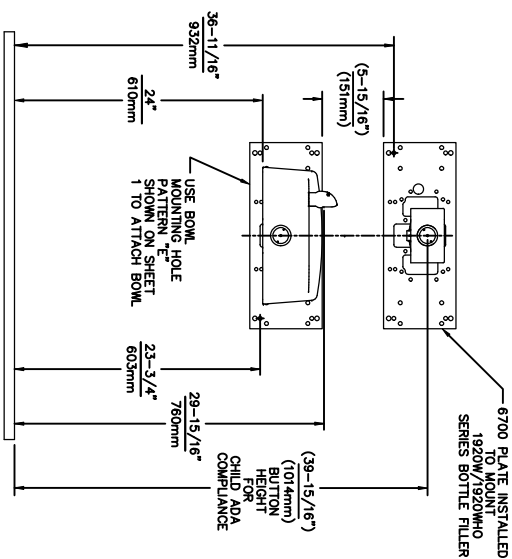

USE THESE DIMENSIONS WITH HAWMS
MODEL:
1107L
AT 24" CHILD HEIGHT *

6700 MOUNTING PLATE
FOR USE WITH BOTTLE FILLER AT
40" MAX. AND
DRINKING FOUNTAIN
AT 24" AND BUBBLER HEIGHT AT 30"
MAX. FOR CHILD ADA HEIGHT
(SEE SHEETS 1 & 4 FOR USE WITH
DRINKING FOUNTAIN AT 27" ADULT
HEIGHT DIMENSIONS)

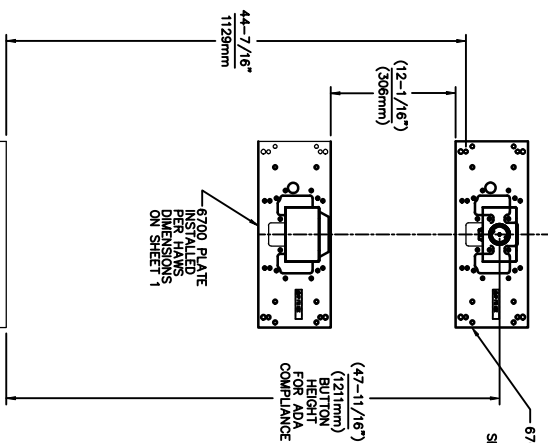

USE THESE MOUNTING DIMENSIONS IF
INSTALLING OVER HAWS WASTE DRIP
TRAY. MODEL: 9468 (SHOWN), 1922
(MODEL 1922 INCLUDES 1920 BOTTLE
FILLER, 1922 BOTTLE FILLER, 1922
BP15, 1922 BACK PANELS (NOT SHOWN),
AT 27" ADULT HEIGHT.

6700 MOUNTING PLATE
FOR USE WITH BOTTLE FILLER
(SEE SHEET 1 FOR USE WITH
DRINKING FOUNTAINS
AND WASTE DRIP TRAY)



Haws
Since 1906

1455 KLEPPE LANE
SPARKS, NEVADA 89431
(775) 359-4712 FAX (775) 359-7424
E-MAIL: HAWS@HAWSCO.COM
WEBSITE: WWW.HAWSCO.COM

ECN NO. REVISED PER BY:	MODEL(S)
5893 1 EON. 6131 FV	6700
DATE: 07/26/23 JS	
CHK'D:	
DATE:	
APPROVED: RH	SCALE: 1:13 DRAWING TYPE: INSTALLATION
	SIZE: A SHEET 6 OF 6
PART NUMBER	REVISION
0002080016	25