

ITEM	DESCRIPTION	PART NO.
1	BOTTLE FILLER, 1011 HS MODELS	HS4
2	BOTTLE FILLER, 1117/1119 HS MODELS	HS6
3	FRAME, MOUNTING, SINGLE, W/CORD, RIVIVE FTN & 2000HSA.8	HS11
4	FRAME, MOUNTING, DUAL, W/CORD, RIVIVE FTN MODELS	HS12
5	FILTER, 12XX EWC, LEAD/CYST/CTO	6428
6	STRAINER, MESH, 110 MICRON, NON-SERVICEABLE	6434
7	PANEL, LOWER, 304 SST, HI-LO	0410000923
8	VALVE, SOLENOID, 3/8 QC, 120VAC	0110000827.4
9	DRAIN BASIN, HS MODELS	0410000894
10	GRATE, 304 SST, HS MODELS	0410000895
11	SCREW, 8-32 UNC X .375, SST, PAN, T-20 TORX	0310000550
12	FUSE, 10A-250VAC, SLOW BLOW, 5MM X 20MM, GLASS	0210001120
13	PCBA, PROXIMITY SENSOR, HS MODELS	0210001175
14	AERATOR, LAMINAR FLOW CONTROL, 1.2 GPM	0110001537
15	AERATOR INSTALLATION TOOL	0510000672
16	RFID BOARD PCBA	0210000745.6
17	COVER, CORNER, HS MODELS	0410000897
18	CLIP, PANEL ATTACHMENT, HS MODELS	0410000903
19	SCREW, 8-32 UNC X .500, SST, PAN, T-20 TORX	0310000551
20	SCREW, 10-24 UNC X .563, SST, BUTTON HEAD, T20 TORX	0310000540
21	BUBBLER HEAD, PCP, 1001 BOWL	5705
22	BUBBLER HEAD, PCP, 1107 AND 1109 FTN	5703M
23	BUTTON, PUSH, 5874, FLANGED W/ VALVE	5874PBF
24	BUTTON, PUSH, 5874, FLANGED	PBA6
25	VALVE REPAIR KIT	VRK5874
26	STRAINER, WASTE ASSEMBLY, SCP OR PCP, 1001 FTN	6463
27	STRAINER, WASTE ASSEMBLY, 1107 AND 1109 FTN	6462
28	PLATE, BOTTOM, 1001 FTN	PBM1000
29	PLATE, BOTTOM, 1107 FTN	PBM1107
30	PLATE, BOTTOM, 1109 FTN	PBM1109
31	PLATE, BOTTOM, 1105 FTN	PBM1105
32	DRIVER, NOZZLE, .25 HEX	0002082253

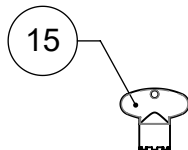

WHEN ORDERING PARTS, PLEASE SPECIFY PART NUMBER

		1455 KLEPPE LANE SPARKS, NEVADA 89431 (775) 359-4712 FAX (775) 359-7424 E-MAIL: HAWS@HAWSO.COM WEBSITE: WWW.HAWSO.COM	
ECN: 6000	REV. ECN: 6000	BY: DHP	MODEL(S)
DRAWN: DHP	DATE: 12/15/22	CHKD: JU	1XXXHSA, DUAL FOUNTAIN MODELS
APPROVED: DHP	DATE: 08/02/24	SCALE: 1:20	DRAWING TYPE: PARTS BREAKDOWN
			PART NUMBER: 0510002202
			REVISION: 1
			SIZE: A SHEET 1 OF 2

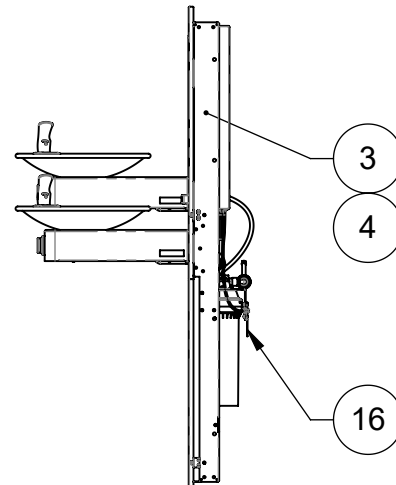
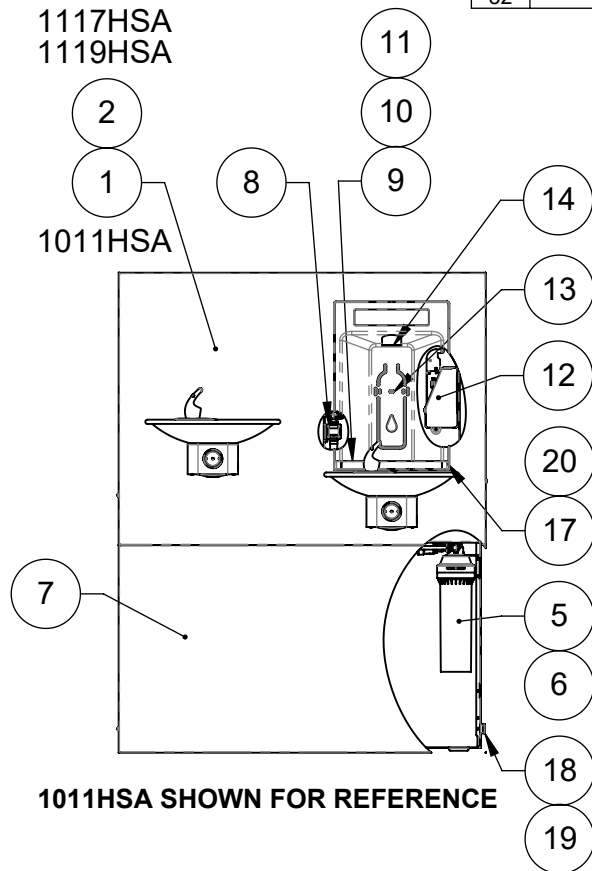
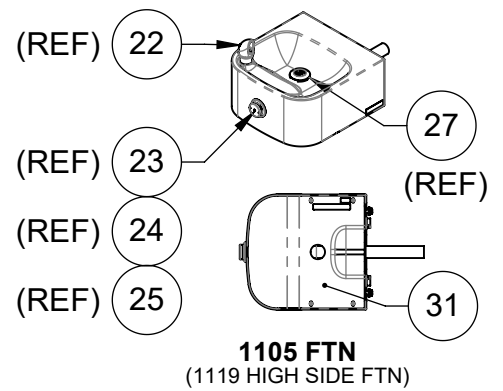
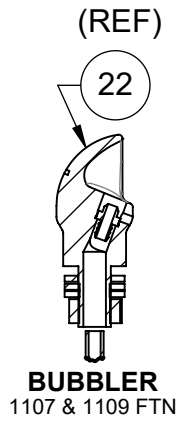
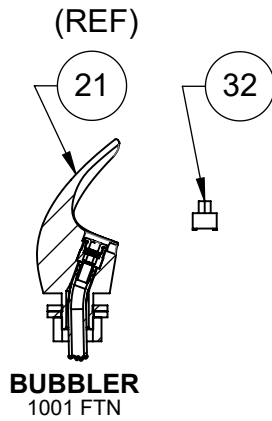
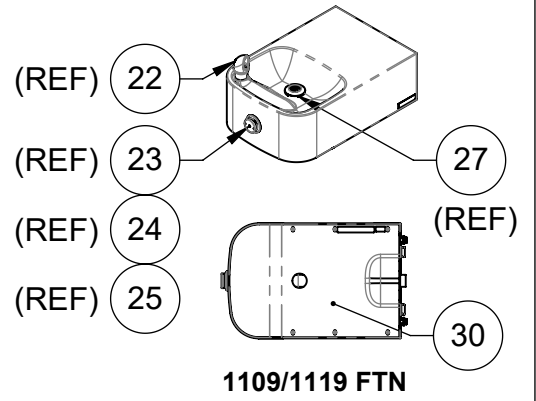
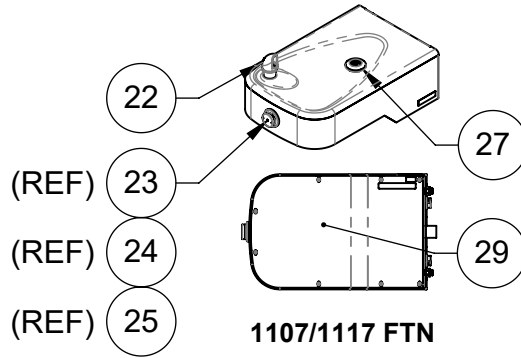
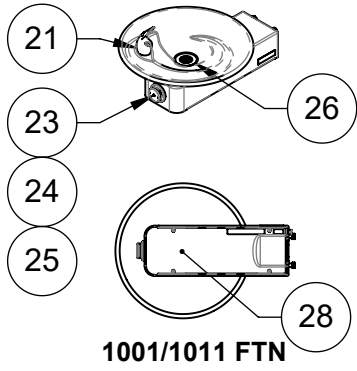

WHEN ORDERING PARTS, PLEASE SPECIFY PART NUMBER

		1455 KLEPPE LANE SPARKS, NEVADA 89431 (775) 359-4712 FAX (775) 359-7424 E-MAIL: HAWS@HAWSO.COM WEBSITE: WWW.HAWSO.COM	
ECN: 6000	REV. ECN: 6000	BY: DHP	MODEL(S) 1XXXHSA, DUAL FOUNTAIN MODELS
DRAWN: DHP	DATE: 12/15/22	CHKD: JU	PART NUMBER 0510002202
APPROVED: DHP	DATE: 08/02/24	SCALE: 1:20	REVISION 1
DRAWING TYPE: PARTS BREAKDOWN		SIZE: A	SHEET 2 OF 2