

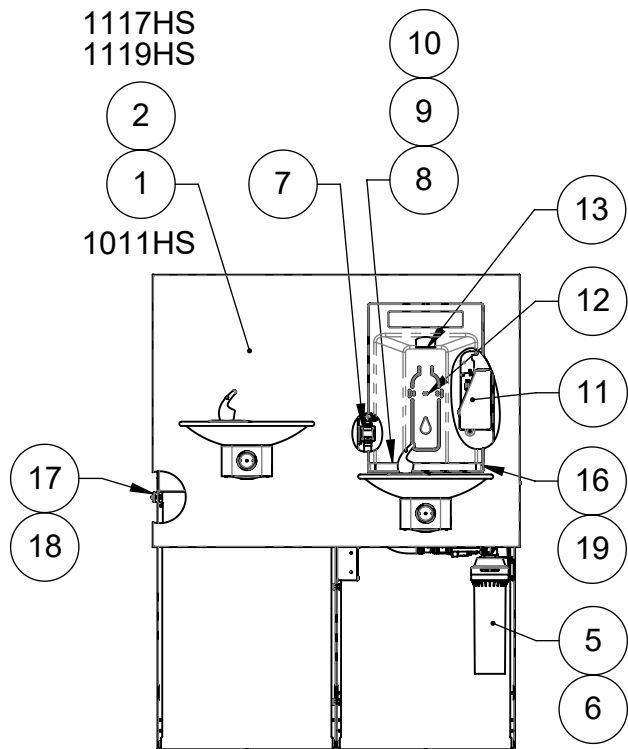

ITEM	DESCRIPTION	PART NO.
1	BOTTLE FILLER, 1011 HS MODELS	HS4
2	BOTTLE FILLER, 1117/1119 HS MODELS	HS6
3	FRAME, MOUNTING, SINGLE, W/CORD, RIVIVE FTN & 2000HSA.8	HS11
4	FRAME, MOUNTING, DUAL, W/CORD, RIVIVE FTN MODELS	HS12
5	FILTER, 12XX EWC, LEAD/CYST/CTO	6428
6	STRAINER, MESH, 110 MICRON, NON-SERVICEABLE	6434
7	VALVE, SOLENOID, 3/8 QC, 120VAC	0110000827.4
8	DRAIN BASIN, HS MODELS	0410000894
9	GRATE, 304 SST, HS MODELS	0410000895
10	SCREW, 8-32 UNC X .375, SST, PAN, T-20 TORX	0310000550
11	FUSE, 10A-250VAC, SLOW BLOW, 5MM X 20MM, GLASS	0210001120
12	PCBA, PROXIMITY SENSOR, HS MODELS	0210001175
13	AERATOR, LAMINAR FLOW CONTROL, 1.2 GPM	0110001537
14	AERATOR INSTALLATION TOOL	0510000672
15	RFID BOARD PCBA	0210000745.6
16	COVER, CORNER, HS MODELS	0410000897
17	CLIP, PANEL ATTACHMENT, HS MODELS	0410000903
18	SCREW, 8-32 UNC X .500, SST, PAN, T-20 TORX	0310000551
19	SCREW, 10-24 UNC X .563, SST, BUTTON HEAD, T20 TORX	0310000540
20	BUBBLER HEAD, PCP, 1001 BOWL	5705
21	BUBBLER HEAD, PCP, 1107 AND 1109 FTN	5703M
22	BUTTON, PUSH, 5874, FLANGED W/ VALVE	5874PBF
23	BUTTON, PUSH, 5874, FLANGED	PBA6
24	VALVE REPAIR KIT	VRK5874
25	STRAINER, WASTE ASSEMBLY, SCP OR PCP, 1001 FTN	6463
26	STRAINER, WASTE ASSEMBLY, 1107 AND 1109 FTN	6462
27	PLATE, BOTTOM, 1001 FTN	PBM1000
28	PLATE, BOTTOM, 1107 FTN	PBM1107
29	PLATE, BOTTOM, 1109 FTN	PBM1109
30	PLATE, BOTTOM, 1105 FTN	PBM1105
31	DRIVER, NOZZLE, .25 HEX	0002082253

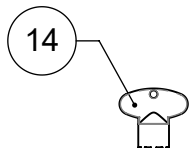

1011HS SHOWN FOR REFERENCE

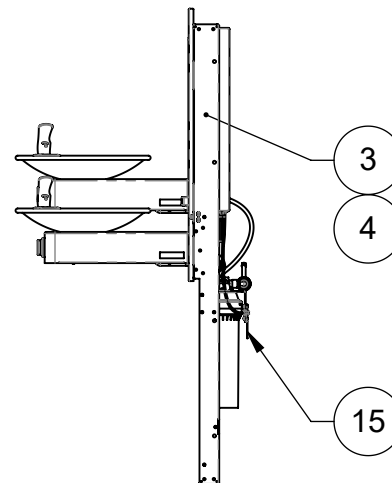

			1455 KLEPPE LANE SPARKS, NEVADA 89431 (775) 359-4712 FAX (775) 359-7424 E-MAIL: HAWS@HAWS.CO.COM WEBSITE: WWW.HAWS.CO.COM	
ECN: 6000	REV. ECN: 6000	BY: DHP	MODEL(S)	PART NUMBER
DRAWN: DHP	DATE: 12/15/22	CHKD: DHP	1XXXHS, DUAL FOUNTAIN MODELS, REAR ACCESS	0510002203
APPROVED: JU	DATE: 07/08/24			REVISION 1
SCALE: 1:20			DRAWING TYPE: PARTS BREAKDOWN	SIZE: A SHEET 1 OF 2

WHEN ORDERING PARTS, PLEASE SPECIFY PART NUMBER

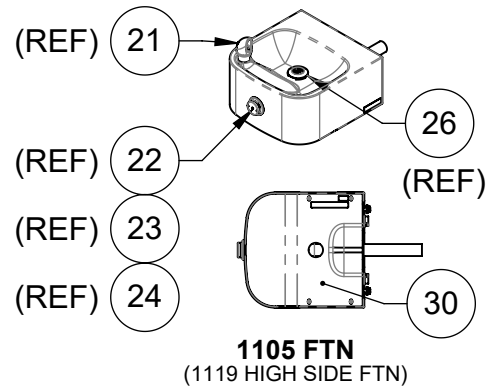
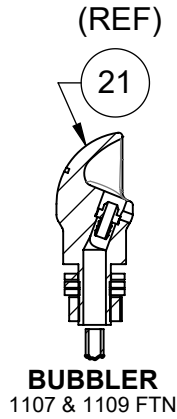
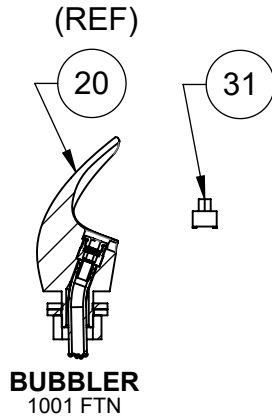
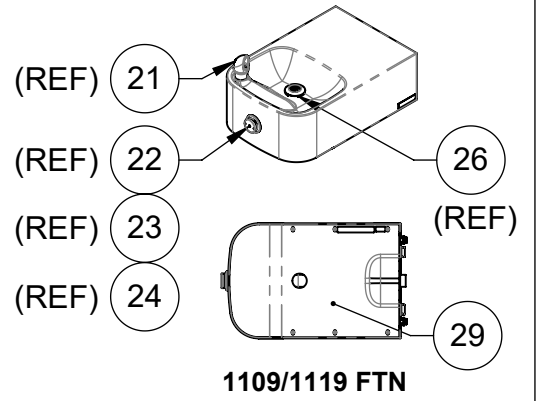
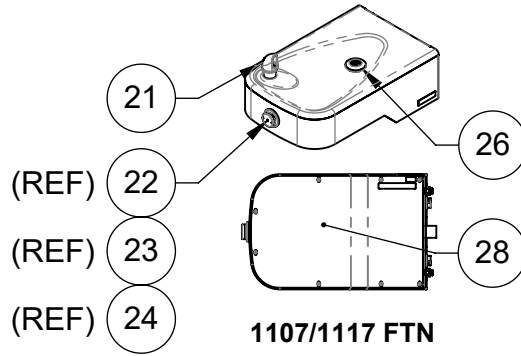
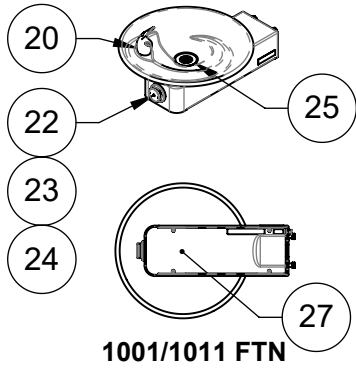

WHEN ORDERING PARTS, PLEASE SPECIFY PART NUMBER

		1455 KLEPPE LANE SPARKS, NEVADA 89431 (775) 359-4712 FAX (775) 359-7424 E-MAIL: HAWS@HAWSO.COM WEBSITE: WWW.HAWSO.COM	
ECN: 6000	REV. ECN: 6000	BY: DHP	MODEL(S) 1XXXHS, DUAL FOUNTAIN MODELS, REAR ACCESS
DRAWN: DHP	DATE: 12/15/22	CHKD: DHP	PART NUMBER 0510002203
APPROVED: JU	DATE: 07/08/24	SCALE: 1:20	REVISION 1
		DRAWING TYPE: PARTS BREAKDOWN	SIZE: A
		SHEET 2 OF 2	