

NOTES:

1. HOLD ROUGH-IN DIMENSIONS $\pm 1/4"$ (6.4mm).
2. WHEN INSTALLING THIS UNIT, LOCAL, STATE, OR FEDERAL CODES SHOULD BE ADHERED TO. INSTALL A TRAP IN THE WASTE LINE AND A SCREWDRIVER STOP IN THE SUPPLY LINE IF REQUIRED.

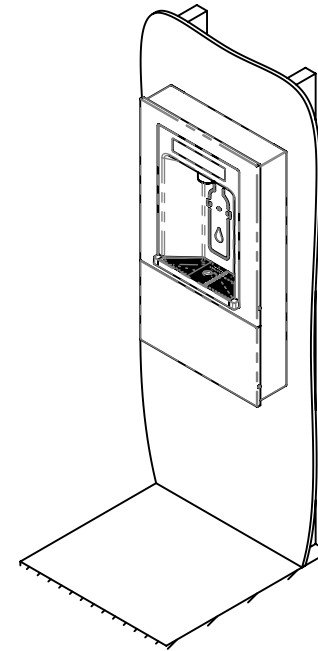
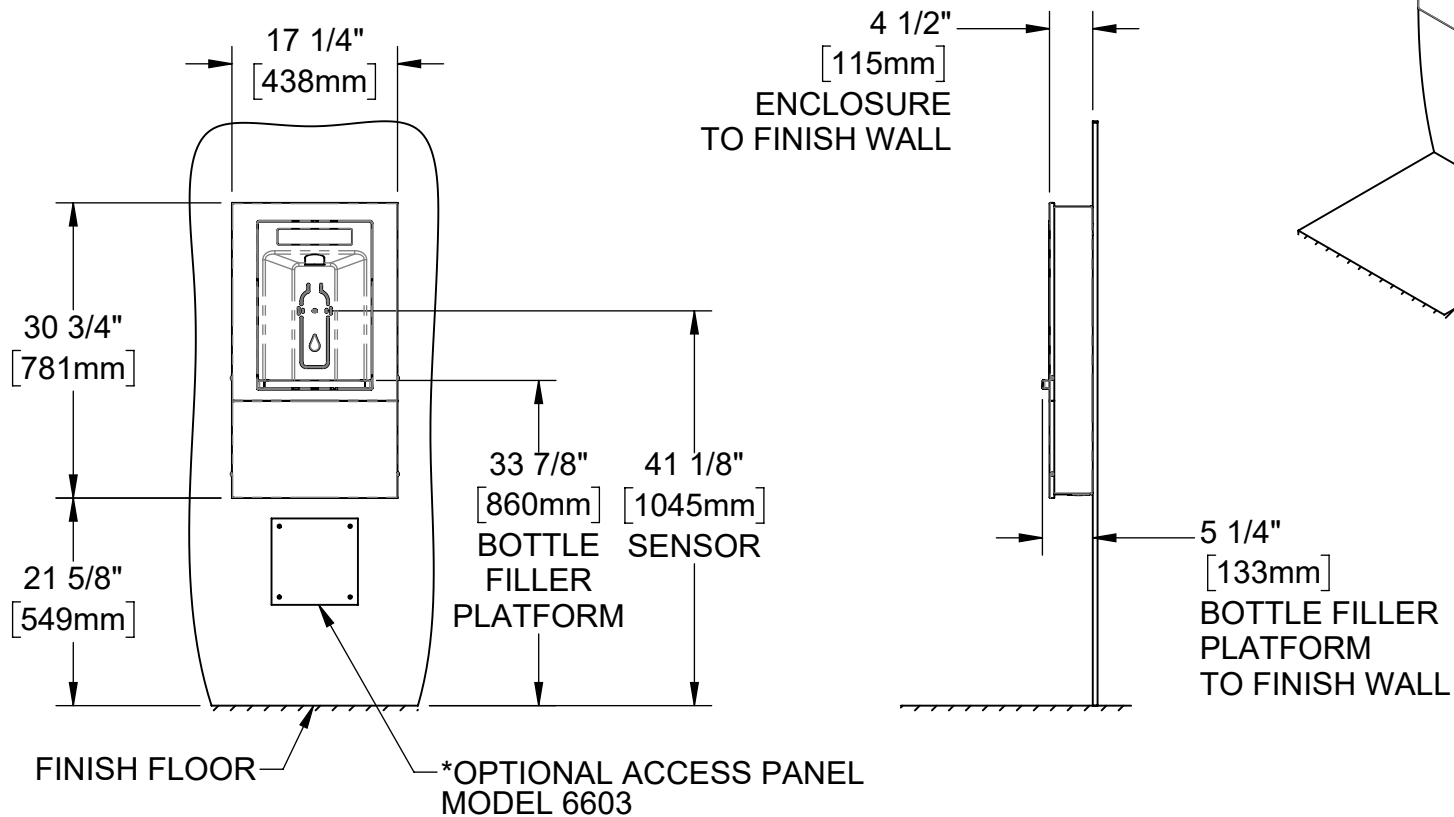

			1455 KLEPPE LANE SPARKS, NEVADA 89431 (775) 359-4712 FAX (775) 359-7424 E-MAIL: HAWS@HAWS.CO.COM WEBSITE: WWW.HAWS.CO.COM	
			ECN: 6000 DRAWN: DHP APPROVED: DHP	REV. ECN: 6000 DATE: 08/16/23 DATE: 08/02/24
SCALE: 1:20 DRAWING TYPE: INSTALLATION SIZE: A			SHEET 1 OF 7	

NOTES:

3. ROUGH IN ELECTRICAL, WASTE PLUMBING, AND WATER SUPPLY WITH DIMENSIONS SHOWN.
4. INSTALL 120V AC (60HZ) 15-AMP GFCI-PROTECTED OUTLET (NOT SUPPLIED) IN SPECIFIED LOCATION.

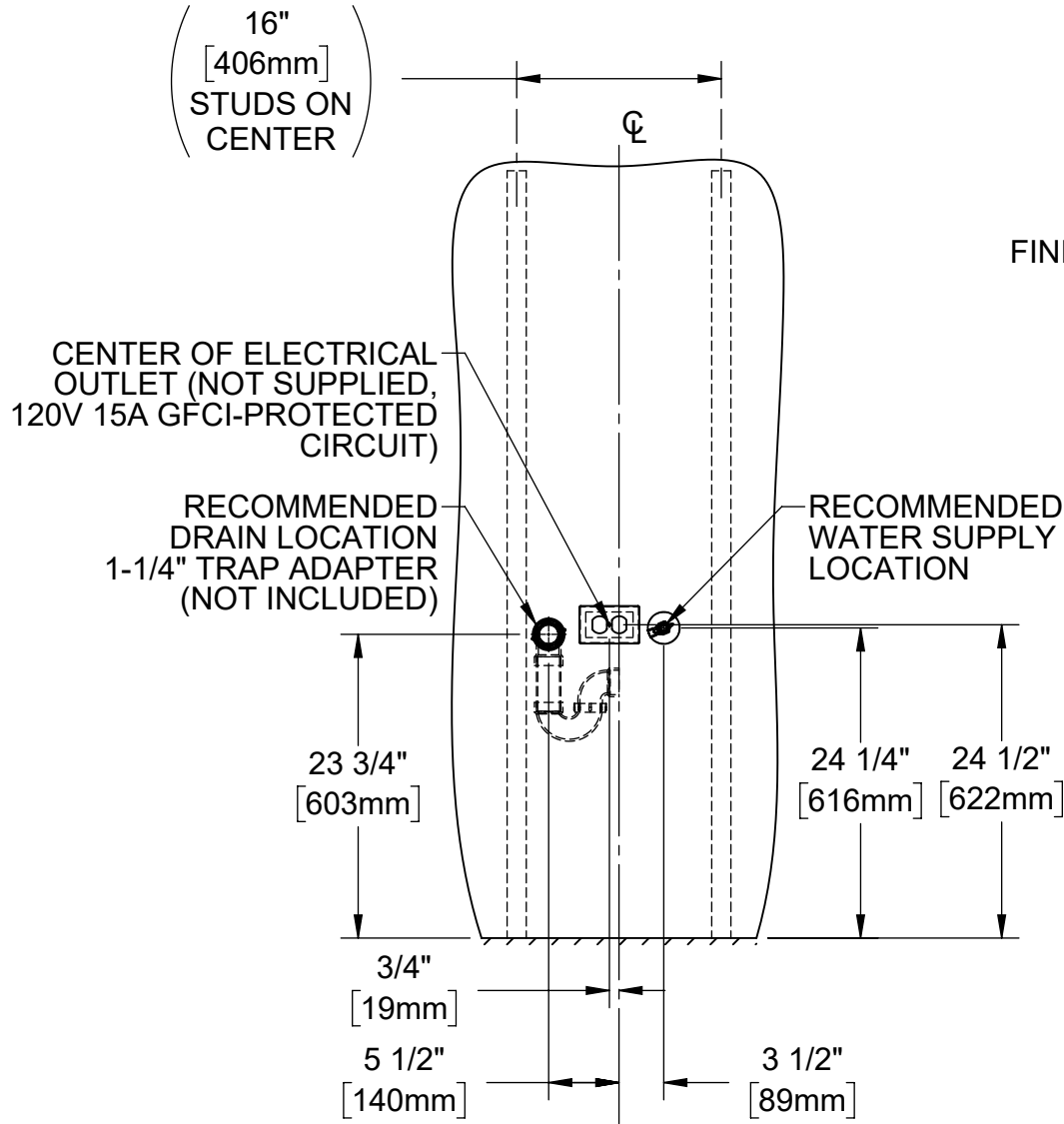

TYPICAL WALL OPENING

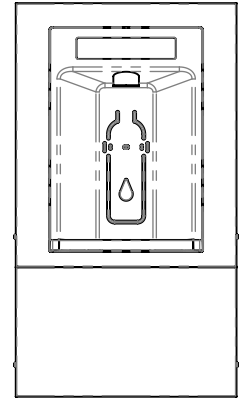
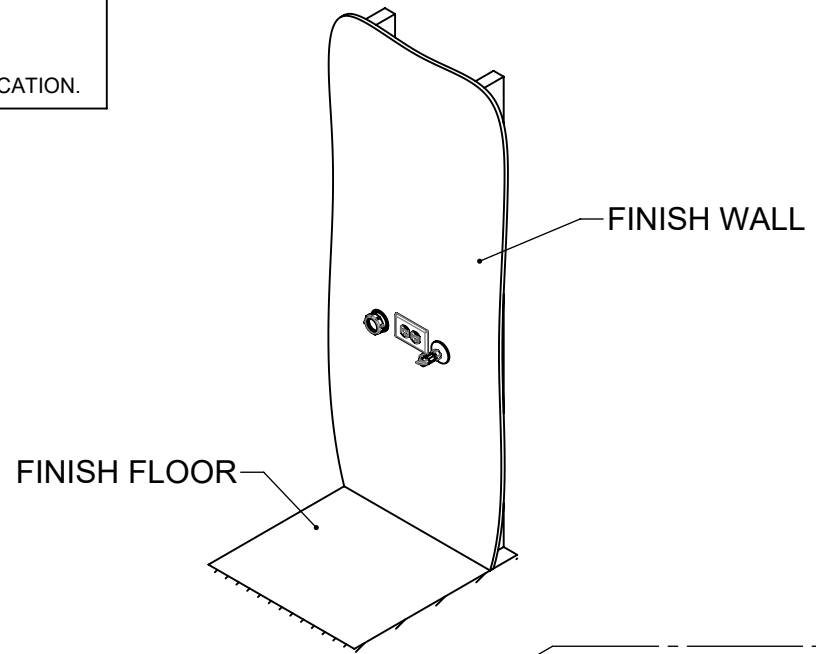

*NOTE:
REMOVABLE HOLE PLUGS ON BOTTOM ALLOW FOR ALTERNATE ROUGH IN CONFIGURATIONS

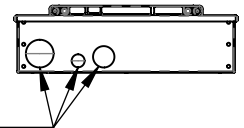

1455 KLEPPE LANE
SPARKS, NEVADA 89431
(775) 359-4712 FAX (775) 359-7424
E-MAIL: HAWS@HAWS.CO.COM
WEBSITE: WWW.HAWS.CO.COM

ECN: 6000	REV. ECN: 6000	BY: DHP	MODEL(S): 2000HSSM, BOTTLE FILLER	PART NUMBER: 0510002226.D
DRAWN: DHP	DATE: 08/16/23	CHKD: DN		REVISION: 1
APPROVED: DHP	DATE: 08/02/24	SCALE: 1:20	DRAWING TYPE: INSTALLATION	SHEET 2 OF 7

NOTES:

5. REMOVE LOWER PANEL BY REMOVING 2X #8-32 PANEL SCREWS (T20 TORX).
6. REMOVE WATER FILTER AND SET ASIDE.
7. REMOVE MOUNTING BRACKET FROM BOTTLE FILLER ASSEMBLY BY REMOVING #10-24 PANEL SCREW IN REAR OF UNIT.
8. INSTALL MOUNTING BRACKET LEVEL TO FLOOR AND CENTERED BETWEEN STUDS USING 4X 1/4" STRUCTURAL SCREWS (NOT SUPPLIED).

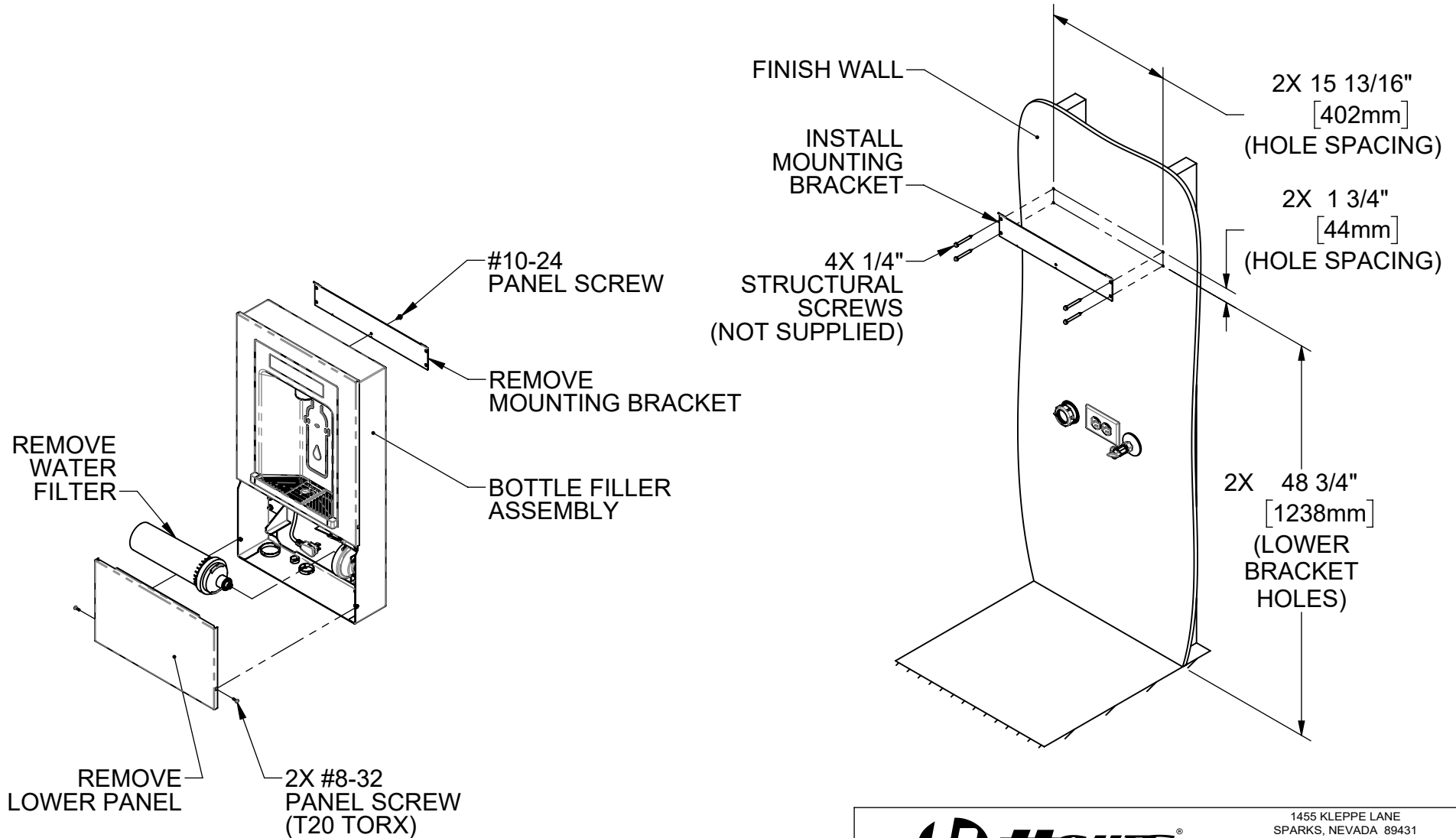

(DRAIN AND WATER SUPPLY COMPONENTS HIDDEN FOR CLARITY)

		1455 KLEPPE LANE SPARKS, NEVADA 89431 (775) 359-4712 FAX (775) 359-7424 E-MAIL: HAWS@HAWSO.COM WEBSITE: WWW.HAWSO.COM	
		ECN: 6000 DRAWN: DHP APPROVED: DHP	REV. ECN: 6000 DATE: 08/16/23 DATE: 08/02/24
MODEL(S) 2000HSSM, BOTTLE FILLER		SCALE: 1:15 DRAWING TYPE: INSTALLATION SIZE: A SHEET 3 OF 7	

NOTES:

- 9. HANG BOTTLE FILLER ON MOUNTING BRACKET.
- 10. INSTALL 2X 1/4" STRUCTURAL SCREWS TO SECURE ENCLOSURE TO WALL.

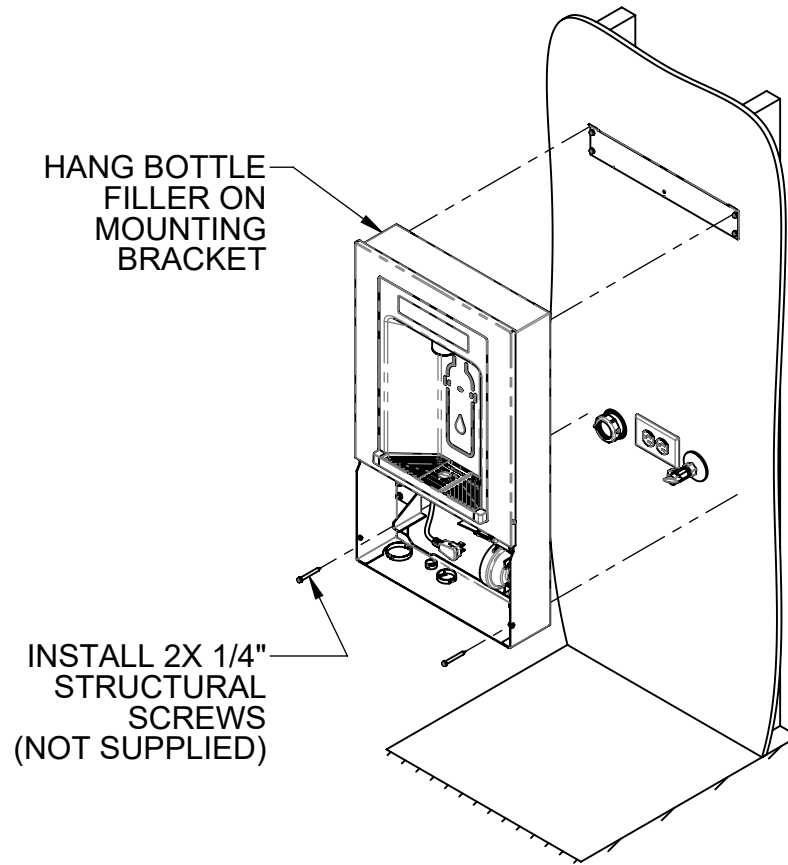

(DRAIN AND WATER SUPPLY COMPONENTS HIDDEN FOR CLARITY)

			1455 KLEPPE LANE SPARKS, NEVADA 89431 (775) 359-4712 FAX (775) 359-7424 E-MAIL: HAWS@HAWS.CO.COM WEBSITE: WWW.HAWS.CO.COM		
			ECN: 6000	REV. ECN: 6000	BY: DHP
DRAWN: DHP	DATE: 08/16/23	CHKD: DN			REVISION 1
APPROVED: DHP	DATE: 08/02/24	SCALE: 1:15	DRAWING TYPE: INSTALLATION	SIZE: A	SHEET 4 OF 7

NOTES:

11. ATTACH DRAIN HOSE TO DRAIN STACK USING SUPPLIED DRAIN HOSE ADAPTER AND HOSE CLAMP. ENSURE THAT DRAIN HOSE HAS A DOWNWARD SLOPE ALONG ITS FULL LENGTH.
12. ADHERE TO LOCAL, STATE, AND/OR FEDERAL CODES FOR PROPER DRAIN STACK AND TRAP INSTALLATION.

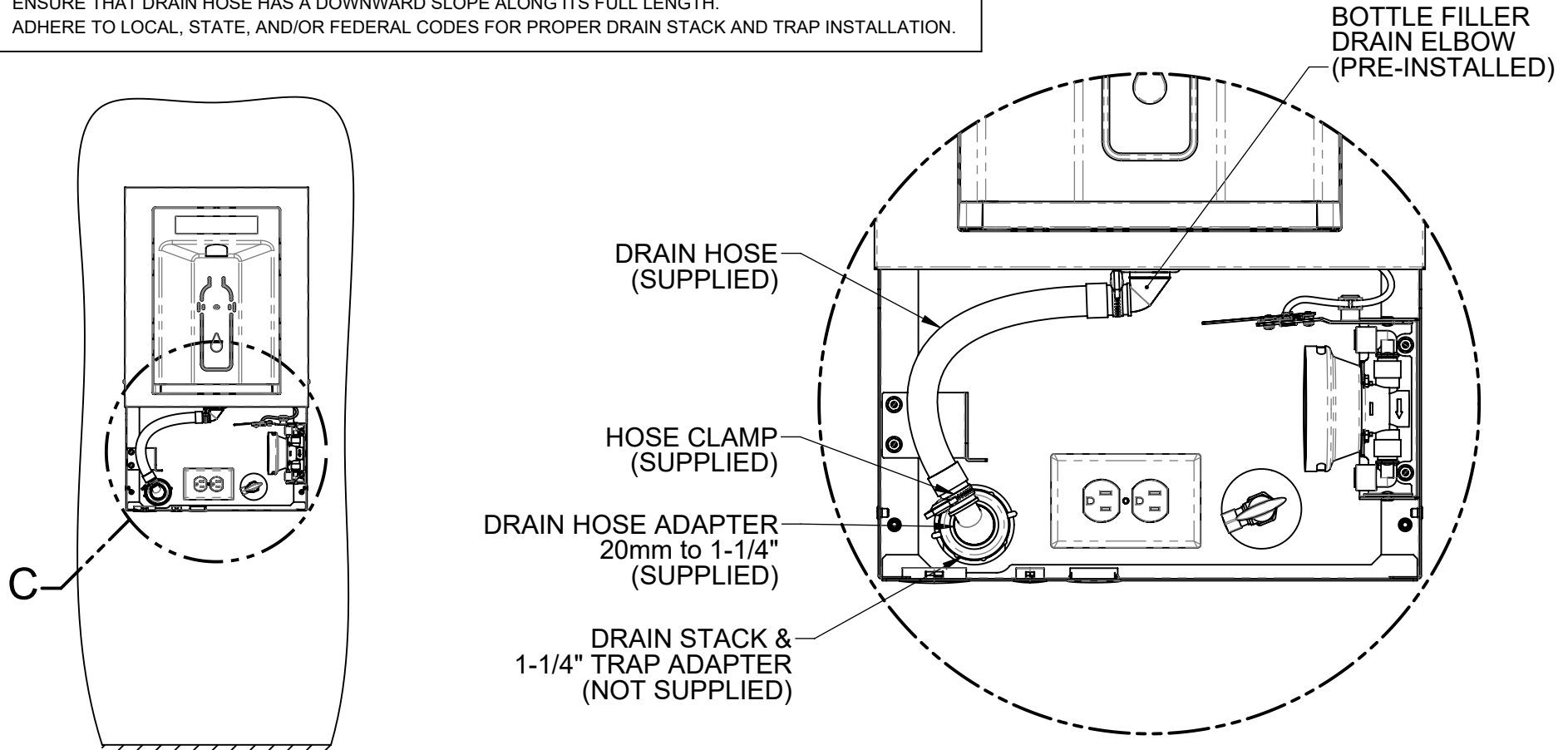

DETAIL C
(ELECTRICAL AND WATER SUPPLY COMPONENTS HIDDEN FOR CLARITY)

DRAIN HOSE ADAPTER INSTALLATION

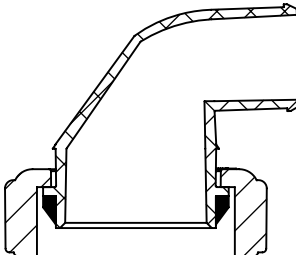

- 1-1/4" TRAP ADAPTER (NOT SUPPLIED)
- 1-1/4" SLIP JOINT WASHER (SUPPLIED)
- 1-1/4" NUT (SUPPLIED)

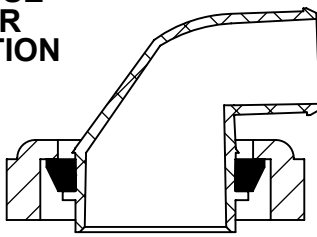

- 1-1/2" TRAP ADAPTER (NOT SUPPLIED)
- 1-1/2" X 1-1/4" SLIP JOINT WASHER (NOT SUPPLIED)
- 1-1/2" NUT (NOT SUPPLIED)



1455 KLEPPE LANE
SPARKS, NEVADA 89431
(775) 359-4712 FAX (775) 359-7424
E-MAIL: HAWS@HAWS.CO.COM
WEBSITE: WWW.HAWS.CO.COM

ECN: 6000	REV. ECN: 6000	BY: DHP	MODEL(S): 2000HSSM, BOTTLE FILLER	PART NUMBER: 0510002226.D
DRAWN: DHP	DATE: 08/16/23	CHKD: DN		REVISION: 1
APPROVED: DHP	DATE: 08/02/24	SCALE: 1:15	DRAWING TYPE: INSTALLATION	SIZE: A SHEET 5 OF 7

NOTES:

12. INSTALL 3/8" TUBING AS SHOWN. NOTE DIRECTION OF FLOW ARROWS ON FILTER. CUT ALL TUBING SQUARE AND CLEAN AS REQUIRED. ENSURE TUBING IS FULLY INSERTED INTO PUSH-TO-CONNECT FITTINGS.
13. CONNECT THE WATER SUPPLY LINE TO THE WATER SUPPLY STOP USING COMPRESSION NUT (INCLUDED WITH YOUR SUPPLY STOP), FOLLOWED BY THE PLASTIC FERRULE (SUPPLIED), AND THE BRASS TUBE SUPPORT (SUPPLIED). INSERT SUPPLY LINE INTO THE SUPPLY STOP UNTIL IT BOTTOMS OUT. THREAD THE NUT ONTO THE SUPPLY STOP UNTIL FINGER TIGHT. PUT A LINE ON THE NUT USING A MARKER. TIGHTEN EXACTLY ONE ADDITIONAL FULL TURN (360 DEG) WITH A WRENCH, USING THE LINE TO COUNT TURNS. *NOTE THE CORRECT ORIENTATION OF THE PLASTIC FERRULE. *DO NOT USE THE BRASS FERRULE INCLUDED WITH YOUR SUPPLY VALVE.

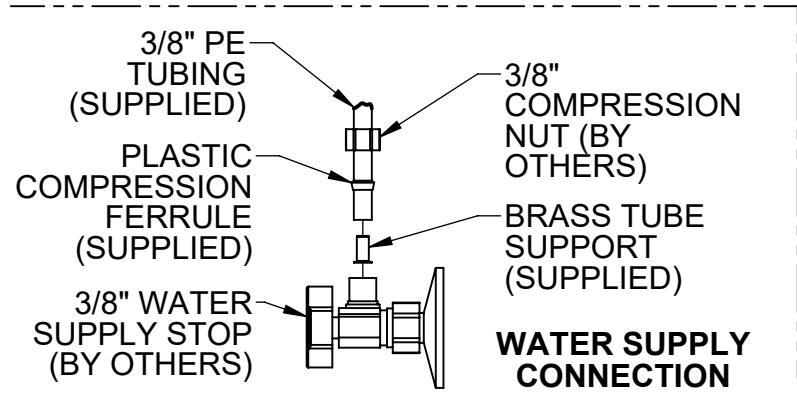
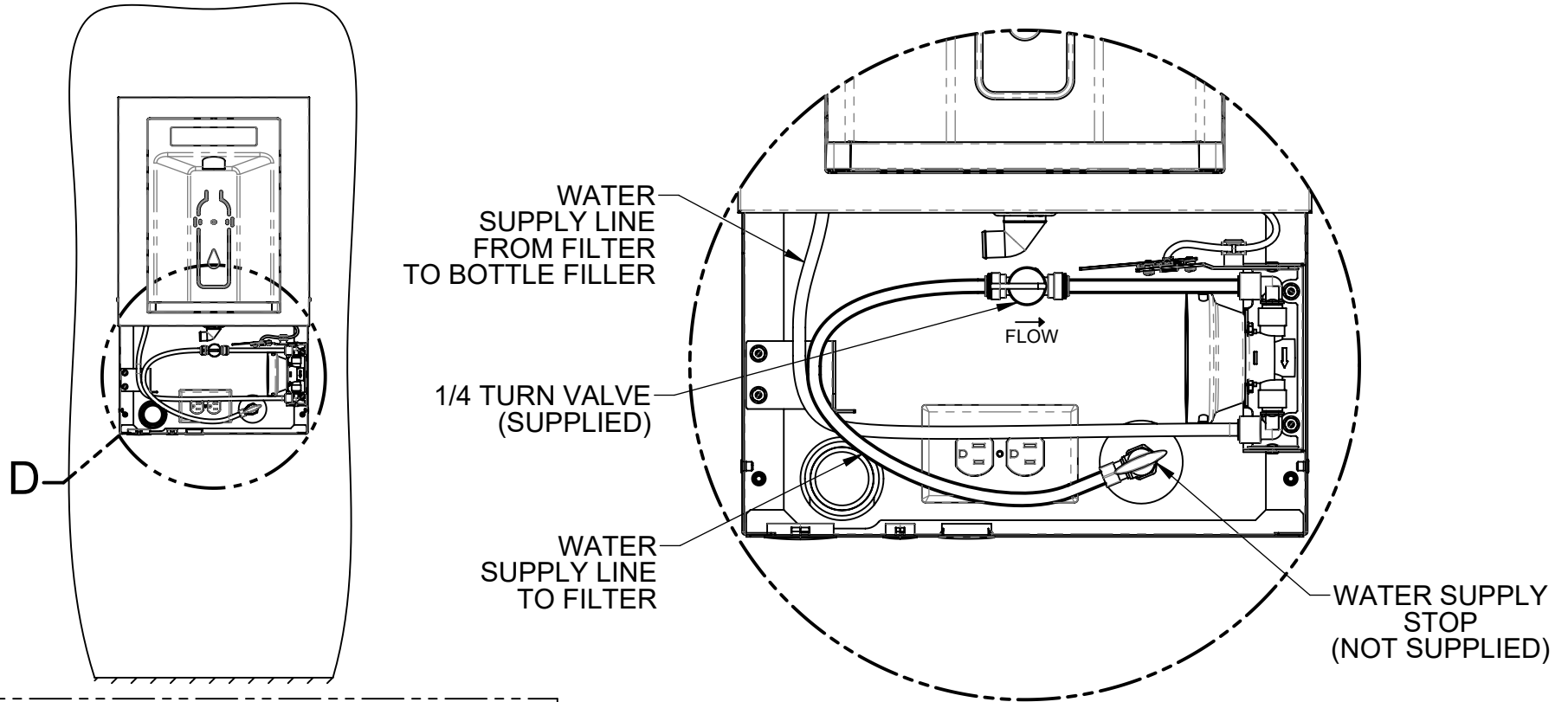

DETAIL D
(DRAIN AND ELECTRICAL COMPONENTS HIDDEN FOR CLARITY)

 Haws Since 1906		1455 KLEPPE LANE SPARKS, NEVADA 89431 (775) 359-4712 FAX (775) 359-7424 E-MAIL: HAWS@HAWS.CO.COM WEBSITE: WWW.HAWS.CO.COM	
		ECN: 6000 REV. ECN: 6000 DRAWN: DHP APPROVED: DHP	BY: DHP DATE: 08/16/23 CHKD: DN DATE: 08/02/24
SCALE: 1:15		DRAWING TYPE: INSTALLATION	
SIZE: A		SHEET 6 OF 7	

NOTES:

14. INSTALL WATER FILTER AND TURN ON WATER SUPPLY.
15. CHECK ALL FITTINGS FOR LEAKS AND ENSURE DRAIN FITTINGS ARE TIGHT.
16. CONNECT BOTTLE FILLER POWER CORD PLUG TO WALL OUTLET.
17. INSTALL LOWER PANEL USING 2X #8-32 PANEL SCREWS (PREVIOUSLY REMOVED).
18. INSTALLATION COMPLETE.

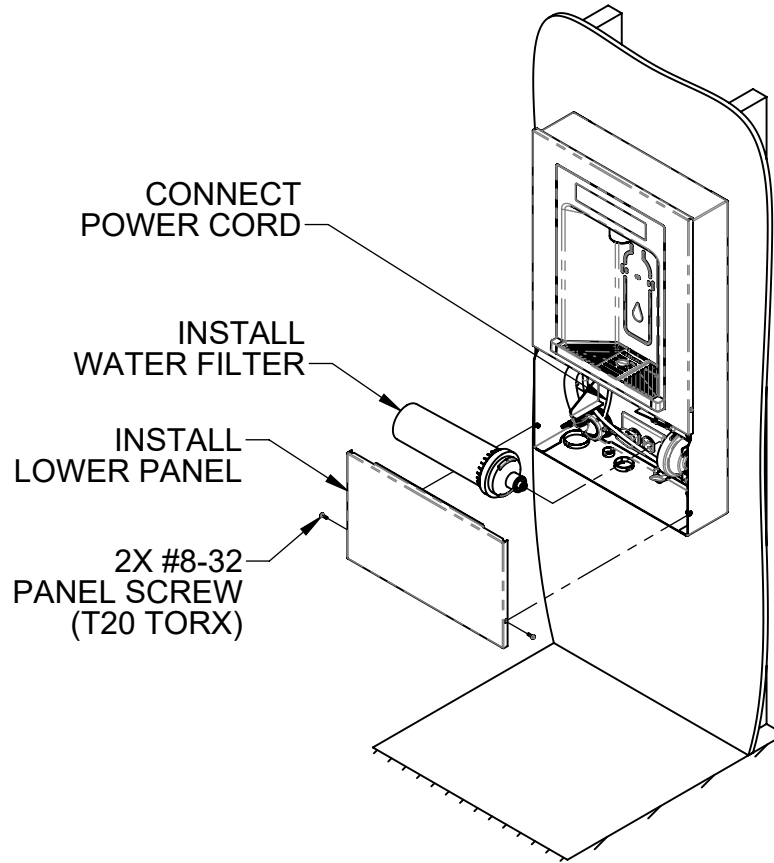

1455 KLEPPE LANE
 SPARKS, NEVADA 89431
 (775) 359-4712 FAX (775) 359-7424
 E-MAIL: HAWS@HAWS.CO.COM
 WEBSITE: WWW.HAWS.CO.COM

ECN: 6000	REV. ECN: 6000	BY: DHP	MODEL(S) 2000HSSM, BOTTLE FILLER	PART NUMBER 0510002226.D
DRAWN: DHP	DATE: 08/16/23	CHKD: DN		REVISION 1
APPROVED: DHP	DATE: 08/02/24	SCALE: 1:15	DRAWING TYPE: INSTALLATION	SIZE: A
				SHEET 7 OF 7