

**NOTES:**

1. HOLD ROUGH-IN DIMENSIONS  $\pm 1/4"$  (6.4mm).
2. WHEN INSTALLING THIS UNIT, LOCAL, STATE, OR FEDERAL CODES SHOULD BE ADHERED TO. FOR CHILD-HEIGHT INSTALLATIONS ON 1107 MODELS, REDUCE DIMENSIONS MARKED (\*) BY 3" [76mm]. INSTALL A TRAP IN THE WASTE LINE AND A SCREWDRIVER STOP IN THE SUPPLY LINE IF REQUIRED.

	A	B	
FOUNTAIN MODELS	BUBBLER HEIGHT	DRAIN HEIGHT	WASTE BEND SIZE
1001/1011	33 13/16" [858mm]	28" [711mm]	1-1/4"
1107/1117	*32 13/16" [834mm]	*27 5/16" [694mm]	1-1/4"
1109/1119	34 7/16" [875mm]	28 1/4" [718mm]	1-1/4"

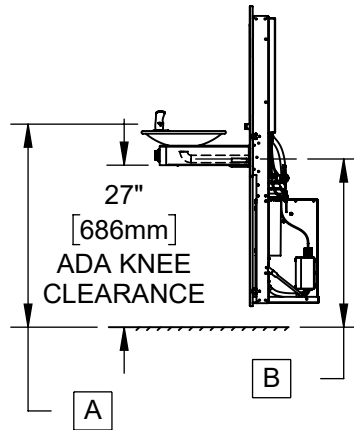
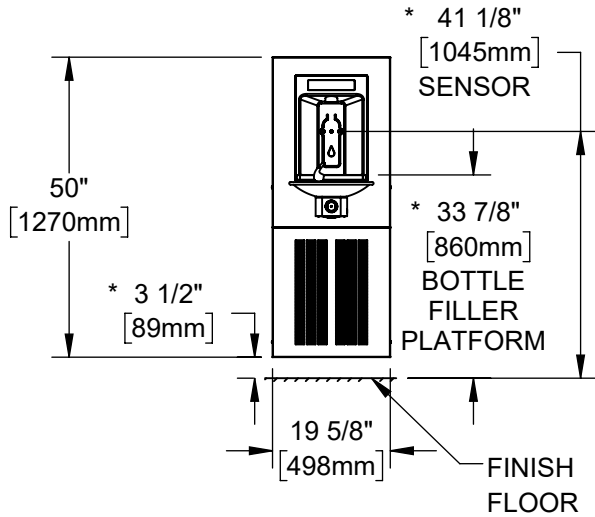
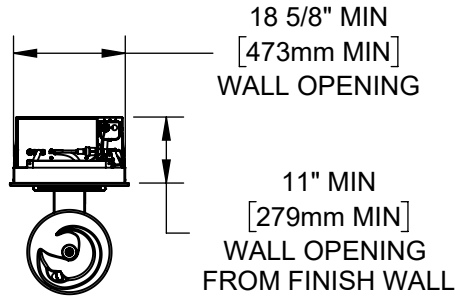

**1001HSA.8**

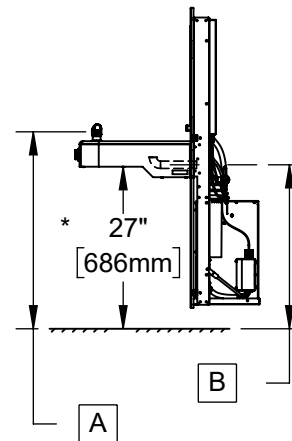

**1107HSA.8**

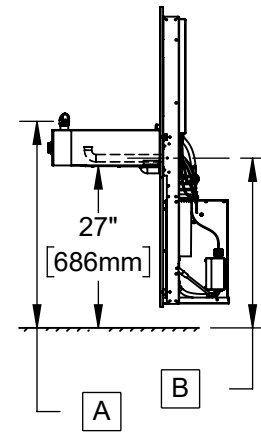

**1109HSA.8**

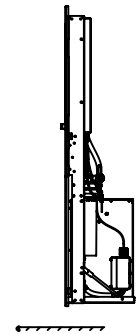

**2000HSA.8**

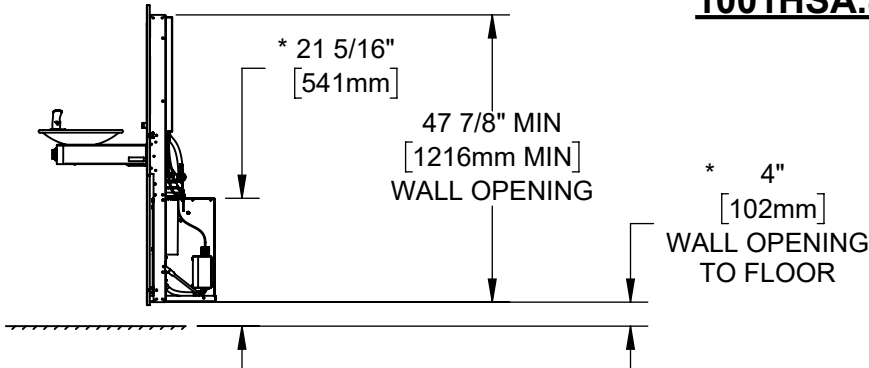

1455 KLEPPE LANE  
SPARKS, NEVADA 89431  
(775) 359-4712 FAX (775) 359-7424  
E-MAIL: HAWS@HAWS.CO.COM  
WEBSITE: WWW.HAWS.CO.COM

ECN: 6000	REV. ECN: 6000	BY: DHP	MODEL(S) 1X0XHSA.8 & 2000HSA.8, SINGLE AND NO FOUNTAIN MODELS, CHILLED	PART NUMBER 0510002218.D
DRAWN: DHP	DATE: 12/15/22	CHKD: DHP		REVISION 1
APPROVED: JU	DATE: 07/08/24	SCALE: 1:32	DRAWING TYPE: INSTALLATION	SIZE: A SHEET 1 OF 11

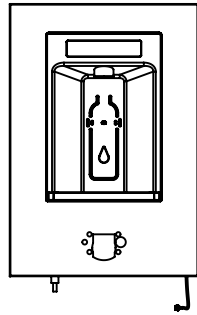

BOTTLE FILLER  
(HS3 SHOWN FOR REFERENCE)

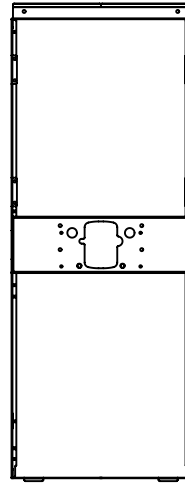

FRAME (HS11)

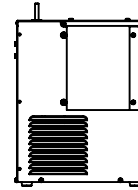

CHILLER  
(HCR8)

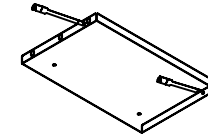

CHILLER TRAY  
(0410000904)

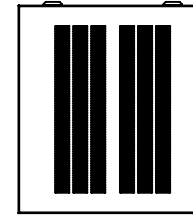

LOWER PANEL  
(0410000922)



1001 FOUNTAIN (HS7)

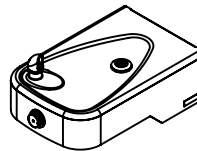

1107 FOUNTAIN (HS8)

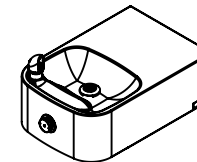

1109 FOUNTAIN (HS9)

HS MODEL #	BOTTLE FILLER	FRAME	CHILLER	CHILLER TRAY	FOUNTAIN	LOWER PANEL	LOOSE PARTS KIT
1001HSA.8	HS3	HS11	HCR8	0410000904	HS7	0410000922	HS102
1107HSA.8	HS5	HS11	HCR8	0410000904	HS8	0410000922	HS102
1109HSA.8	HS5	HS11	HCR8	0410000904	HS9	0410000922	HS102
2000HSA.8	HS2	HS11	HCR8	0410000904	--	0410000922	HS100



1455 KLEPPE LANE  
SPARKS, NEVADA 89431  
(775) 359-4712 FAX (775) 359-7424  
E-MAIL: HAWS@HAWS.CO.COM  
WEBSITE: WWW.HAWS.CO.COM

ECN: 6000	REV. ECN: 6000	BY: DHP	MODEL(S) 1X0XHSA.8 & 2000HSA.8, SINGLE AND NO FOUNTAIN MODELS, CHILLED	PART NUMBER 0510002218.D
DRAWN: DHP	DATE: 12/15/22	CHKD: DHP		REVISION 1
APPROVED: JU	DATE: 07/08/24	SCALE: 1:20	DRAWING TYPE: INSTALLATION	SIZE: A SHEET 2 OF 11

3. ROUGH IN WALL CAVITY WITH DIMENSIONS SHOWN. ROUGH IN ELECTRICAL, WASTE PIPING, AND WATER SUPPLY AS REQUIRED. BE SURE ELECTRICAL, WASTE PIPING, AND WATER SUPPLY IS CLEAR OF THE INSTALLED LOCATION OF THE CHILLER, IN WALL FRAME, AND BOTTLE FILLER.

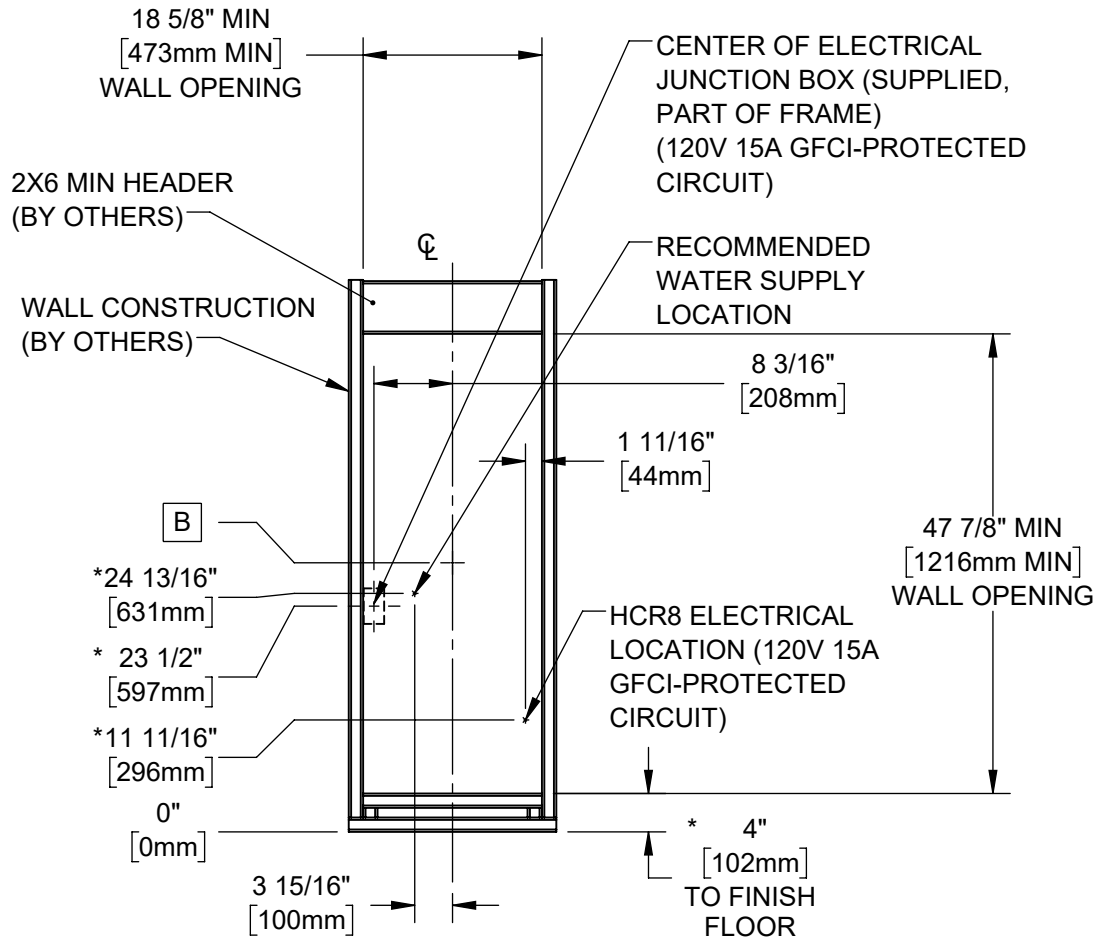

TYPICAL WALL OPENING

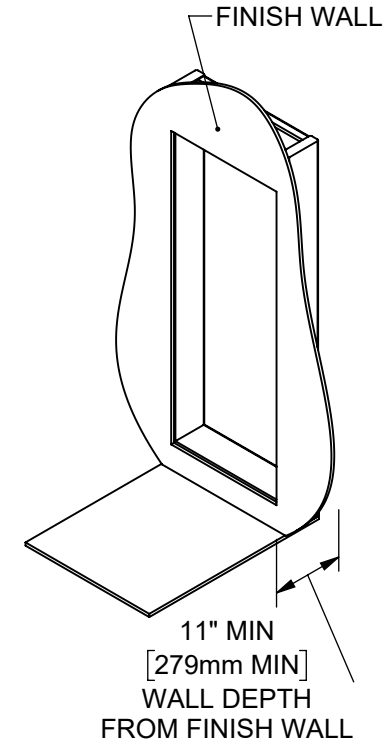

	B	
FOUNTAIN MODELS	DRAIN HEIGHT	WASTE BEND SIZE
1001/1011	28" [711mm]	1-1/4"
1107/1117	*27 5/16" [694mm]	1-1/4"
1109/1119	28 1/4" [718mm]	1-1/4"



**Haws**<sup>®</sup>

Since 1906

1455 KLEPPE LANE  
SPARKS, NEVADA 89431  
(775) 359-4712 FAX (775) 359-7424  
E-MAIL: HAWS@HAWSO.COM  
WEBSITE: WWW.HAWSO.COM

ECN: 6000	REV. ECN: 6000	BY: DHP	MODEL(S): 1X0XHSA.8 & 2000HSA.8, SINGLE AND NO FOUNTAIN MODELS, CHILLED	PART NUMBER: 0510002218.D
DRAWN: DHP	DATE: 12/15/22	CHKD: DHP		REVISION: 1
APPROVED: JU	DATE: 07/08/24	SCALE: 1:20	DRAWING TYPE: INSTALLATION	SHEET 3 OF 11

4. INSTALL HCR8 TRAY USING 2X #10 NUTS (SUPPLIED, DETAIL A). INSTALL 4X PANEL CLIPS (DETAIL B) USING #10 NUTS (SUPPLIED).
5. MOUNT FRAME ASSEMBLY INTO WALL CAVITY USING 12X STRUCTURAL SCREWS (NOT SUPPLIED), USE SHIMS AS NEEDED AND ENSURE THE FRAME IS SQUARE.

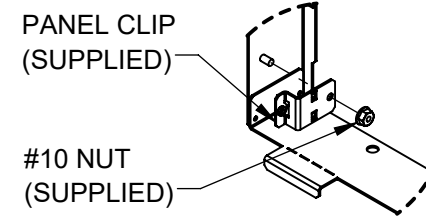

**DETAIL B**  
PANEL CLIP  
INSTALL  
(4 PLACES)

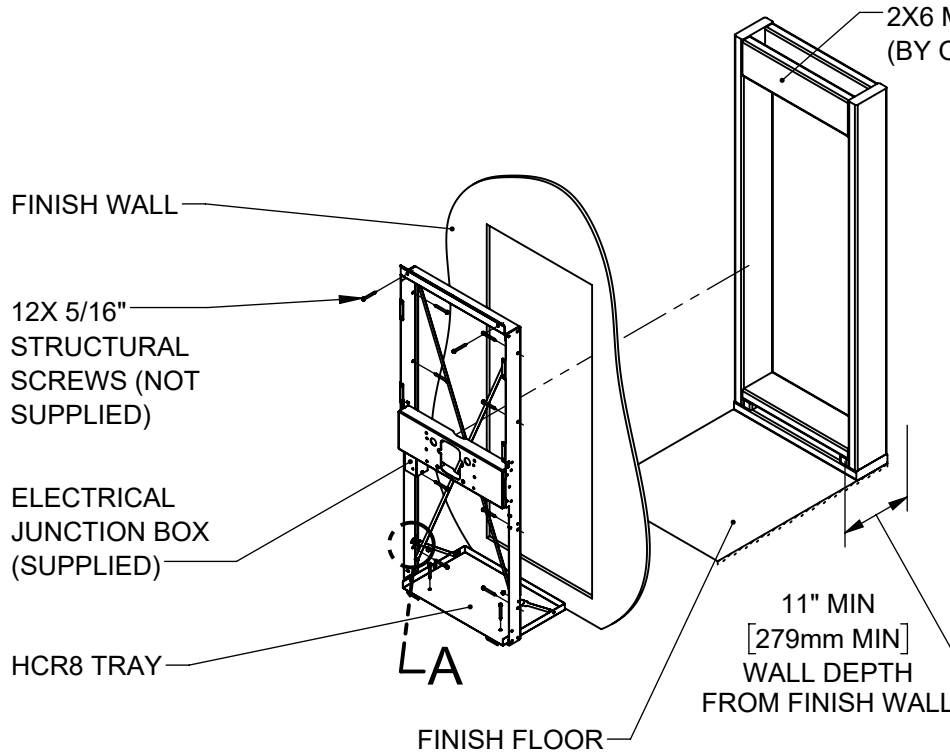

**FRAME INSTALLATION**

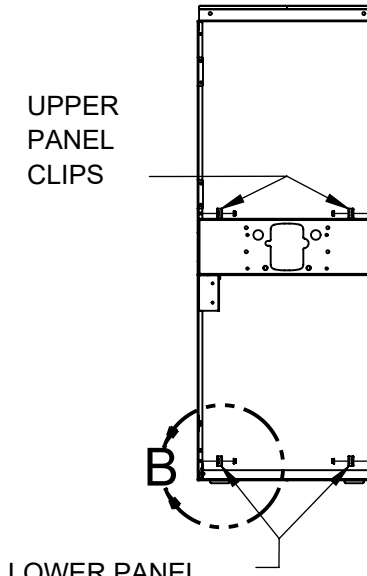

**PANEL CLIP INSTALLATION**

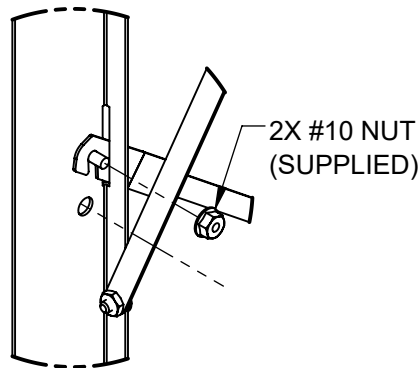

**DETAIL A**

		1455 KLEPPE LANE SPARKS, NEVADA 89431 (775) 359-4712 FAX (775) 359-7424 E-MAIL: HAWS@HAWS.CO.COM WEBSITE: WWW.HAWS.CO.COM	
		ECN: 6000 DRAWN: DHP APPROVED: JU	REV. ECN: 6000 DATE: 12/15/22 DATE: 07/08/24
PART NUMBER 0510002218.D			REVISION 1
SCALE: 1:20   DRAWING TYPE: INSTALLATION		SIZE: A	SHEET 4 OF 11

6. REMOVE SHIPPING BRACKETS FROM FRAME (DETAIL C).
7. INSTALL FILTER HEAD USING 3X SUPPLIED #10 NUTS (DETAIL D).
8. (1001HSA.8 ONLY) INSTALL 1001 DRINKING FOUNTAIN ADAPTER USING 2X SUPPLIED 3/8" NUTS (DETAIL E). ENSURE THE CORRECT ORIENTATION OF THE ADAPTER PLATE, "FRONT" IS PRINTED ON THE ADAPTER PLATE AND SHOULD BE ORIENTED TOWARDS THE FINISH WALL.

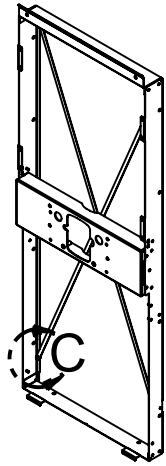

REMOVE SHIPPING  
CROSS BRACING

**DETAIL C**  
(4 PLACES)

**SHIPPING CROSS  
BRACE REMOVAL**

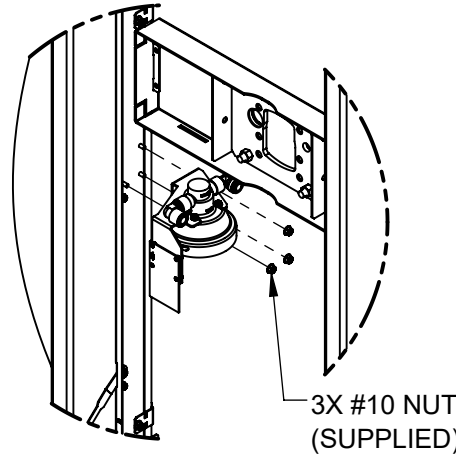

**DETAIL D**  
FILTER/STRAINER HEAD INSTALL  
(ALL MODELS)

3X #10 NUT  
(SUPPLIED)

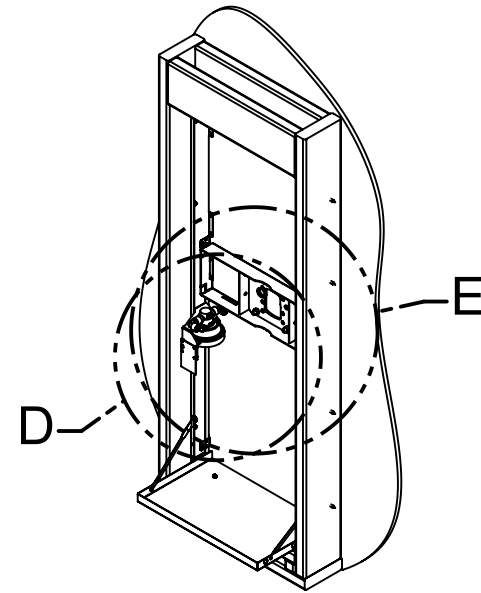

**REAR VIEW**

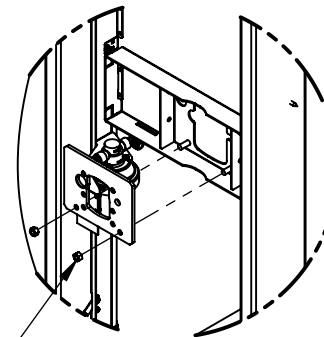

**DETAIL E**  
1001 FOUNTAIN ADAPTER PLATE (1001/1011  
MODELS ONLY)

2X 3/8" NUT  
(SUPPLIED)



1455 KLEPPE LANE  
SPARKS, NEVADA 89431  
(775) 359-4712 FAX (775) 359-7424  
E-MAIL: HAWS@HAWS.CO.COM  
WEBSITE: WWW.HAWS.CO.COM

ECN: 6000	REV. ECN: 6000	BY: DHP	MODEL(S) 1X0XHSA.8 & 2000HSA.8, SINGLE AND NO FOUNTAIN MODELS, CHILLED	PART NUMBER 0510002218.D
DRAWN: DHP	DATE: 12/15/22	CHKD: DHP		REVISION 1
APPROVED: JU	DATE: 07/08/24	SCALE: 1:20	DRAWING TYPE: INSTALLATION	SIZE: A

9. INSTALL 4X 3/8" DRINKING FOUNTAIN BOLTS (SUPPLIED) FROM THE BACK SIDE OF THE FRAME (MODELS WITH FOUNTAINS ONLY).
10. HANG THE BOTTLE FILLER FROM THE TOP OF THE FRAME AND ALIGN THE PANEL SO THE 3/8" DRINKING FOUNTAIN BOLTS PROTRUDE THROUGH THE PANEL IF PRESENT. INSTALL THE 2X #8 PANEL SCREWS (SUPPLIED) ON EITHER SIDE OF THE BOTTLE FILLER PANEL.
11. CONNECT THE FILTER CABLE (RIGHT SIDE OF THE BOTTLE FILLER) TO THE FILTER TRACKING BOARD.

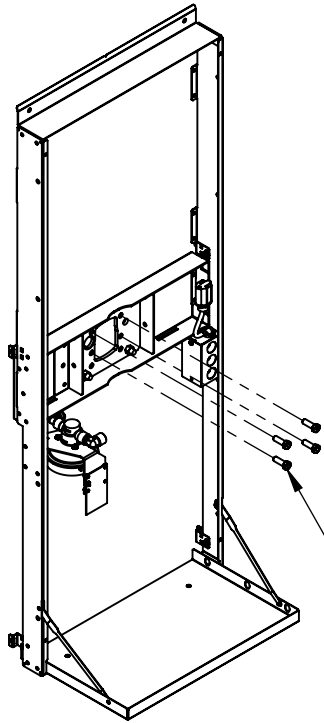

4X DRINKING FOUNTAIN BOLTS (SUPPLIED). USE WASHERS (SUPPLIED) UNDER HEAD OF BOLTS FOR 1107/1117 AND 1109/1119 MODELS

**REAR VIEW**

2X #8-32 BUTTON HEAD PANEL SCREWS (SUPPLIED)

FILTER CABLE

HANG BOTTLE FILLER FROM TOP OF FRAME

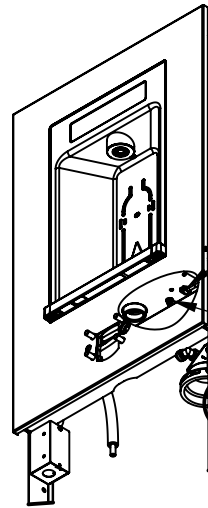
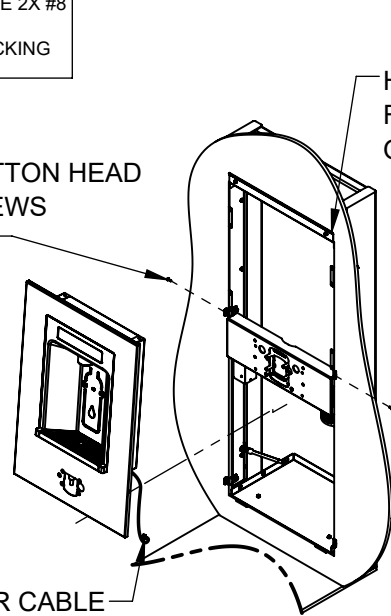

FILTER CABLE

ENERGY SAVINGS COAXIAL RECEPTACLE

F

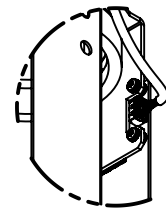
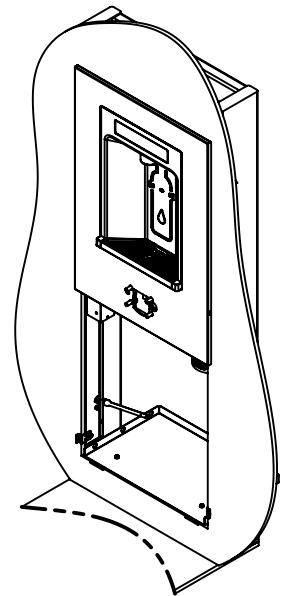

**DETAIL F**  
FILTER TRACKING ELECTRICAL CONNECTION



1455 KLEPPE LANE  
SPARKS, NEVADA 89431  
(775) 359-4712 FAX (775) 359-7424  
E-MAIL: HAWS@HAWSO.COM  
WEBSITE: WWW.HAWSO.COM

ECN: 6000	REV. ECN: 6000	BY: DHP	MODEL(S) 1X0XHSA.8 & 2000HSA.8, SINGLE AND NO FOUNTAIN MODELS, CHILLED	PART NUMBER 0510002218.D
DRAWN: DHP	DATE: 12/15/22	CHKD: DHP		REVISION 1
APPROVED: JU	DATE: 07/08/24	SCALE: 1:14	DRAWING TYPE: INSTALLATION	SIZE: A

- NOTE:** STEPS 12-15 CAN BE PERFORMED LATER IN INSTALLATION IF DESIRED.
- NOTE:** THE BOTTLE FILLER AND HCR8 CHILLER CAN BE SERVICED BY A SINGLE 15AMP GFCI-PROTECTED CIRCUIT IF DESIRED.
- PARTIALLY INSTALL 2X #8 SCREWS (SUPPLIED) INTO RIGHT SIDE OF HCR8 AND HANG THE ENERGY SAVINGS RELAY ENCLOSURE. COMPLETELY TIGHTEN THE 2X #8-32 HEX SCREWS USING A 1/4" OPEN OR BOX END WRENCH TO SECURE THE ENERGY SAVINGS RELAY ENCLOSURE TO THE HCR8.
  - REMOVE THE FRONT PANEL OF THE HCR8 TO ACCESS THE INTERNAL, 120V JUNCTION BOX. REMOVE THE PROVIDED GROMMET, AND HAVE AN ELECTRICIAN CONNECT THE LOOSE LINE, NEUTRAL, AND GROUND CABLES PROVIDED WITH THE ENERGY SAVINGS RELAY ENCLOSURE TO THE RESPECTIVE LINE, NEUTRAL, AND GROUND CONNECTIONS INSIDE THE HCR8 JUNCTION BOX. REPLACE THE HCR8 FRONT PANEL.
  - REMOVE THE 2X COVER SCREWS FOR THE ENERGY SAVINGS RELAY ENCLOSURE AND REMOVE COVER. HAVE AN ELECTRICIAN CONNECT A 120VAC/60HZ 5-AMP GFCI-PROTECTED CIRCUIT TO THE RESPECTIVE LINE, NEUTRAL, AND GROUND CONNECTIONS INSIDE THE ENCLOSURE VIA ONE OF THE AVAILABLE 1/2" KNOCKOUTS.
  - HAVE AN ELECTRICIAN CONNECT A 120VAC/60HZ 15-AMP GFCI-PROTECTED CIRCUIT TO THE RESPECTIVE LINE, NEUTRAL, AND GROUND CONNECTIONS INSIDE THE BOTTLE FILLER JUNCTION BOX VIA ONE OF THE AVAILABLE 1/2" KNOCKOUTS.

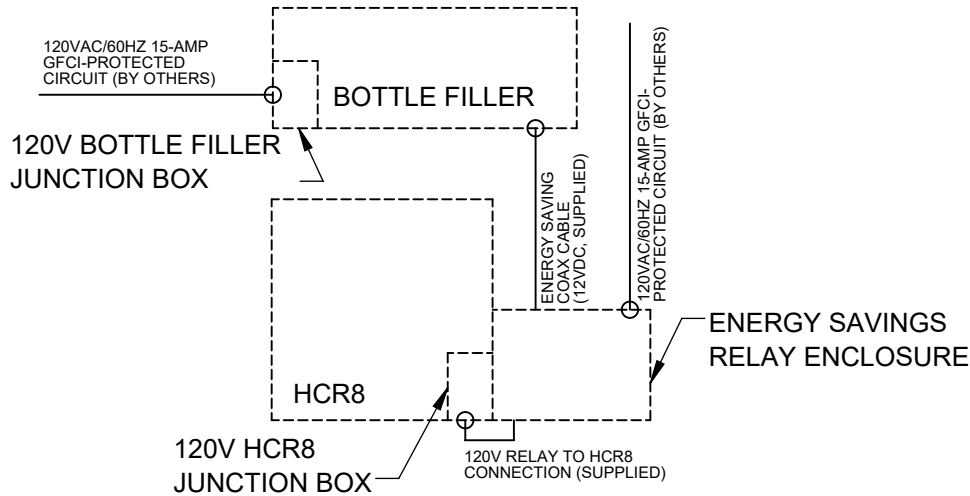
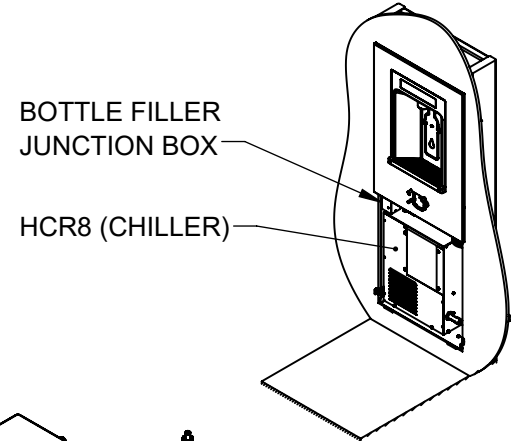

**ELECTRICAL WIRING OVERVIEW**

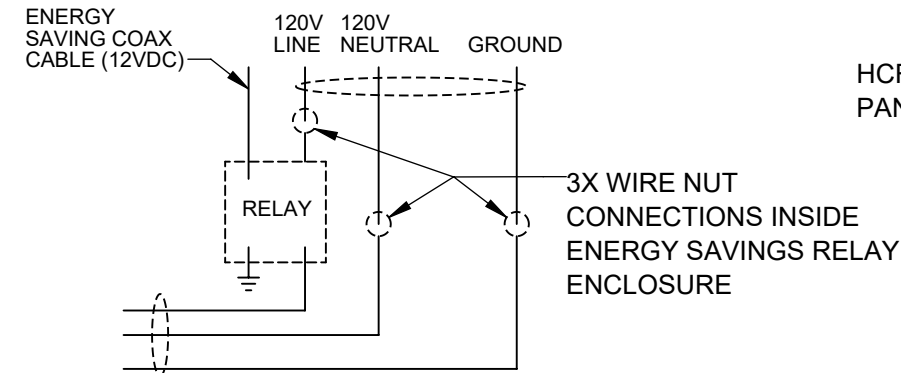

**ENERGY SAVINGS RELAY ENCLOSURE DETAIL**

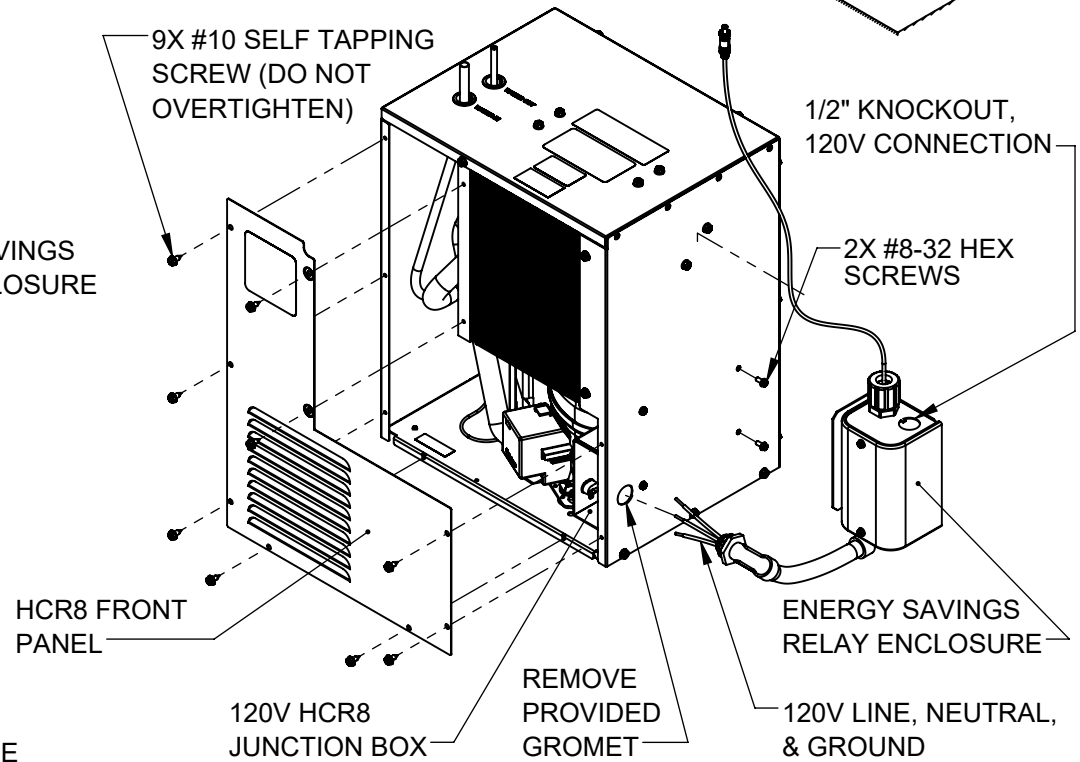

**ENERGY SAVINGS RELAY INSTALLATION**

<p><b>Haws</b> Since 1906</p>		1455 KLEPPE LANE SPARKS, NEVADA 89431 (775) 359-4712 FAX (775) 359-7424 E-MAIL: HAWS@HAWSCO.COM WEBSITE: WWW.HAWSCO.COM	
		ECN: 6000 DRAWN: DHP APPROVED: JU	REV. ECN: 6000 DATE: 12/15/22 DATE: 07/08/24
SCALE: 1:20   DRAWING TYPE: INSTALLATION   SIZE: A		SHEET 7 OF 11	

16. MOUNT THE DRINKING FOUNTAIN TO THE PROTRUDING 3/8" STUDS FROM STEP 9. INSTALL 4X 3/8" NUTS (SUPPLIED) PER DRINKING FOUNTAIN AND TIGHTEN FULLY (25 LB-FT).
17. INSTALL THE WASTE BEND (SUPPLIED), CUT TO LENGTH AS REQUIRED. REFER TO SHEET 3 FOR DRAIN HEIGHTS FOR EACH MODEL. INSTALL THE WATER SUPPLY BUSHING (SUPPLIED) INTO THE CIRCULAR OPENING IN THE MOUNTING PLATE OF THE DRINKING FOUNTAIN. SET LOWER COVER AND #8 PAN HEAD SCREWS ASIDE, THESE WILL BE INSTALLED ONCE THE WATER SUPPLY PLUMBING IS COMPLETE.

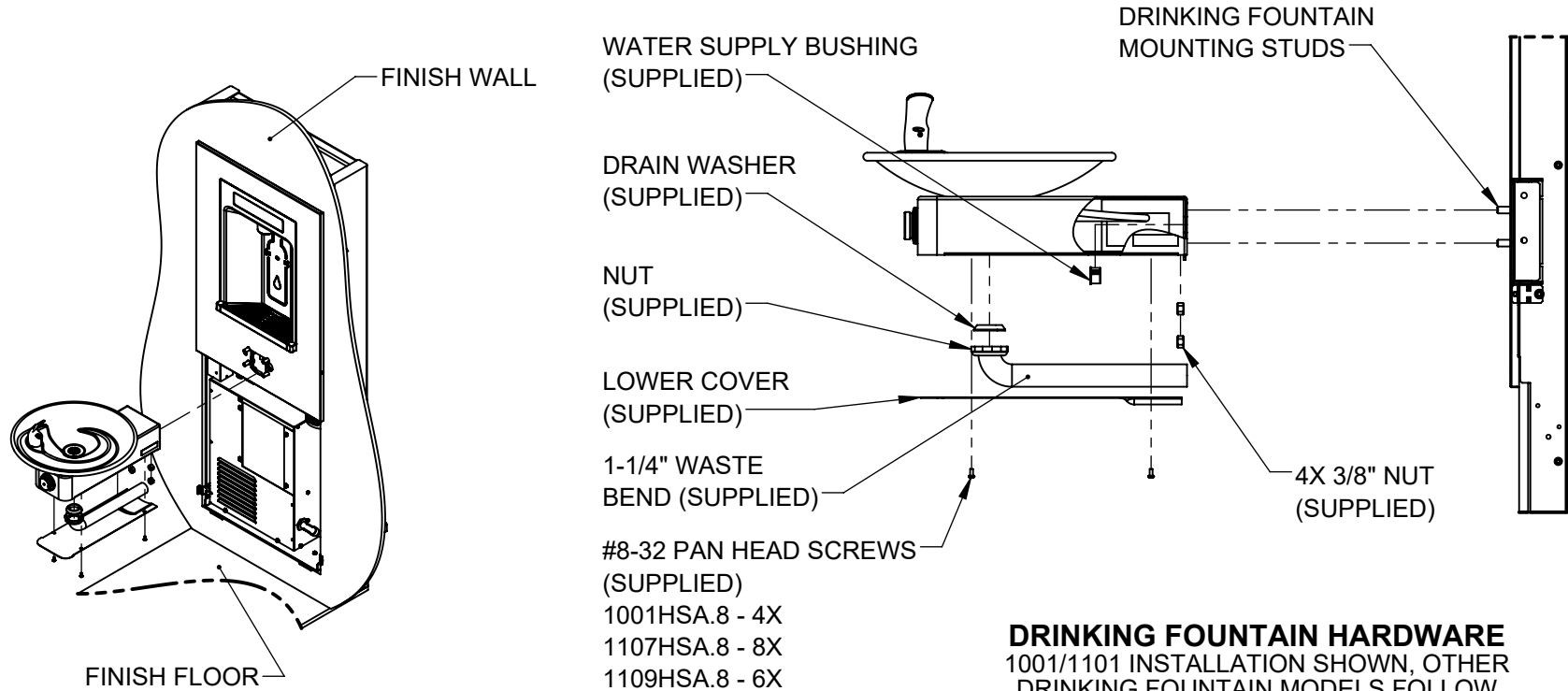

**DRINKING FOUNTAIN HARDWARE**  
 1001/1101 INSTALLATION SHOWN, OTHER DRINKING FOUNTAIN MODELS FOLLOW THE SAME INSTALLATION STEPS AND CONTAIN SIMILAR PARTS.

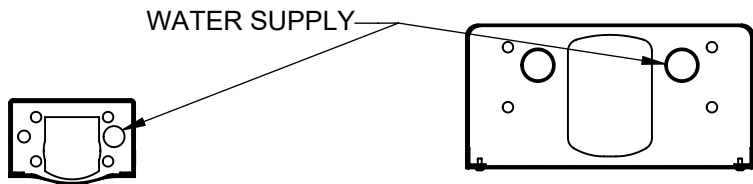

**1001/1101  
 HOLE  
 PATTERN**

**1107/1117 &  
 1109/1119 HOLE  
 PATTERN**

 <b>Haws</b> Since 1906		1455 KLEPPE LANE SPARKS, NEVADA 89431 (775) 359-4712 FAX (775) 359-7424 E-MAIL: HAWS@HAWSO.COM WEBSITE: WWW.HAWSO.COM	
		ECN: 6000 REV. ECN: 6000 DRAWN: DHP APPROVED: JU	BY: DHP DATE: 12/15/22 DATE: 07/08/24
SCALE: 1:20		DRAWING TYPE: INSTALLATION	
SIZE: A		SHEET 8 OF 11	



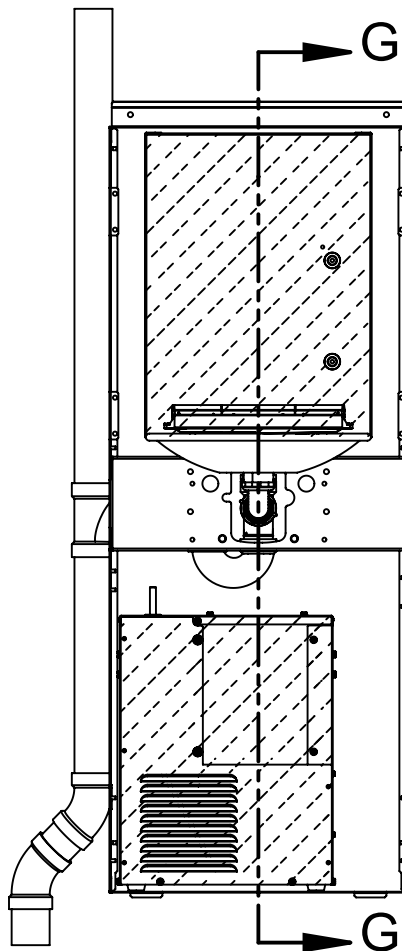

**FRONT VIEW**  
(SOME COMPONENTS HIDDEN FOR CLARITY)

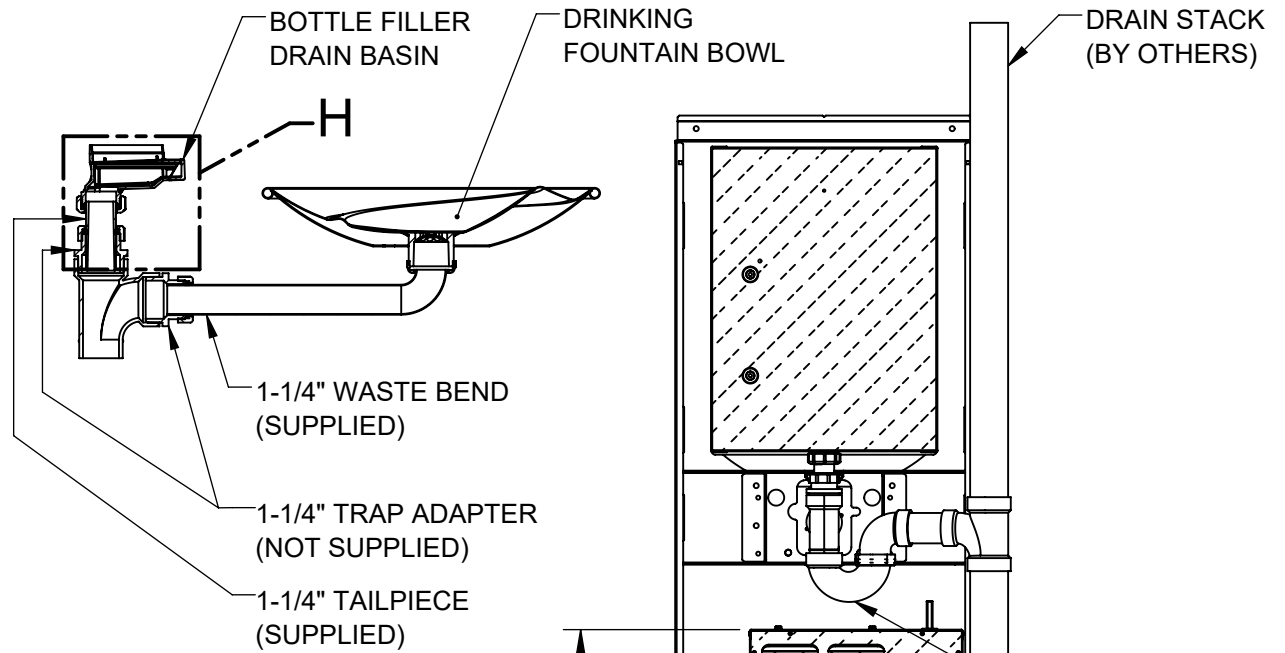

**SECTION G-G**  
(ENLARGED)

21 5/16"  
[541mm]  
TO FINISH FLOOR

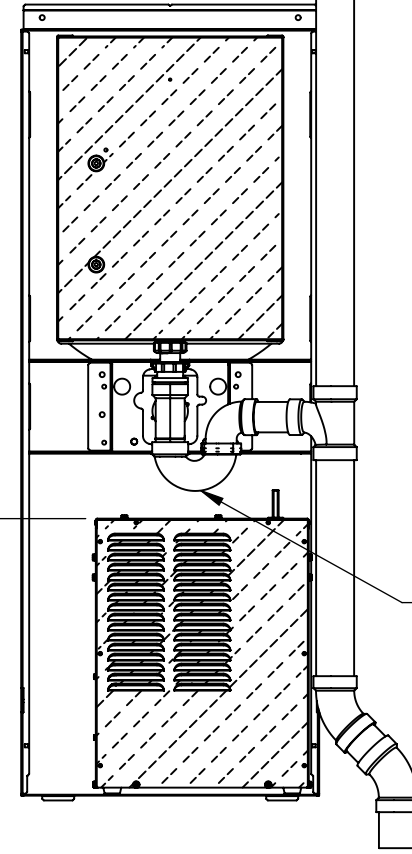

**BACK VIEW**  
(SOME COMPONENTS HIDDEN FOR CLARITY)

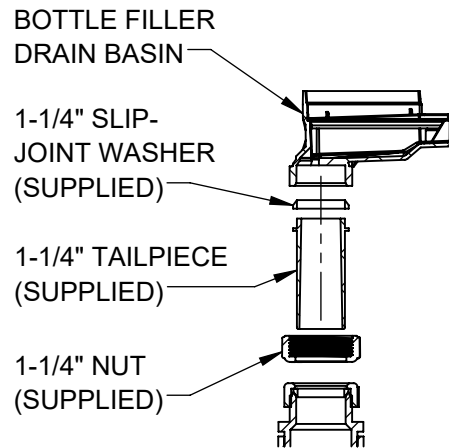

**DETAIL H**  
(EXPLODED VIEW)

**FOR REFERENCE ONLY**

DRAIN STACK SHOWN AS REFERENCE ONLY. LOCAL, STATE, OR FEDERAL CODES SHOULD BE ADHERED TO FOR PROPER DRAIN INSTALLATION.

		1455 KLEPPE LANE SPARKS, NEVADA 89431 (775) 359-4712 FAX (775) 359-7424 E-MAIL: HAWS@HAWS.CO.COM WEBSITE: WWW.HAWS.CO.COM	
		ECN: 6000 DRAWN: DHP APPROVED: JU	REV. ECN: 6000 DATE: 12/15/22 DATE: 07/08/24
SCALE: 1:12   DRAWING TYPE: INSTALLATION   SIZE: A			PART NUMBER: 0510002218.D REVISION: 1 SHEET 9 OF 11

18. INSTALL 3/8" TUBING AS SHOWN. ALL TUBING DOWNSTREAM OF THE HCR8 CHILLER SHOULD BE INSTALLED WITH TUBING INSULATION (SUPPLIED). NOTE DIRECTION OF FLOW ARROWS ON FILTER AND PRESSURE REDUCING VALVE. CUT ALL TUBING AND INSULATION AS REQUIRED. ENSURE TUBING IS CUT SQUARE AND FULLY INSERTED INTO PUSH-TO-CONNECT FITTINGS. MAKE SURE THE POLYETHYLENE WATER TUBES DO NOT CONTACT THE HCR8 CHILLER PANELS. HEAT AND/OR VIBRATIONS FROM THE CHILLER COULD CAUSE DAMAGE TO THE TUBING.

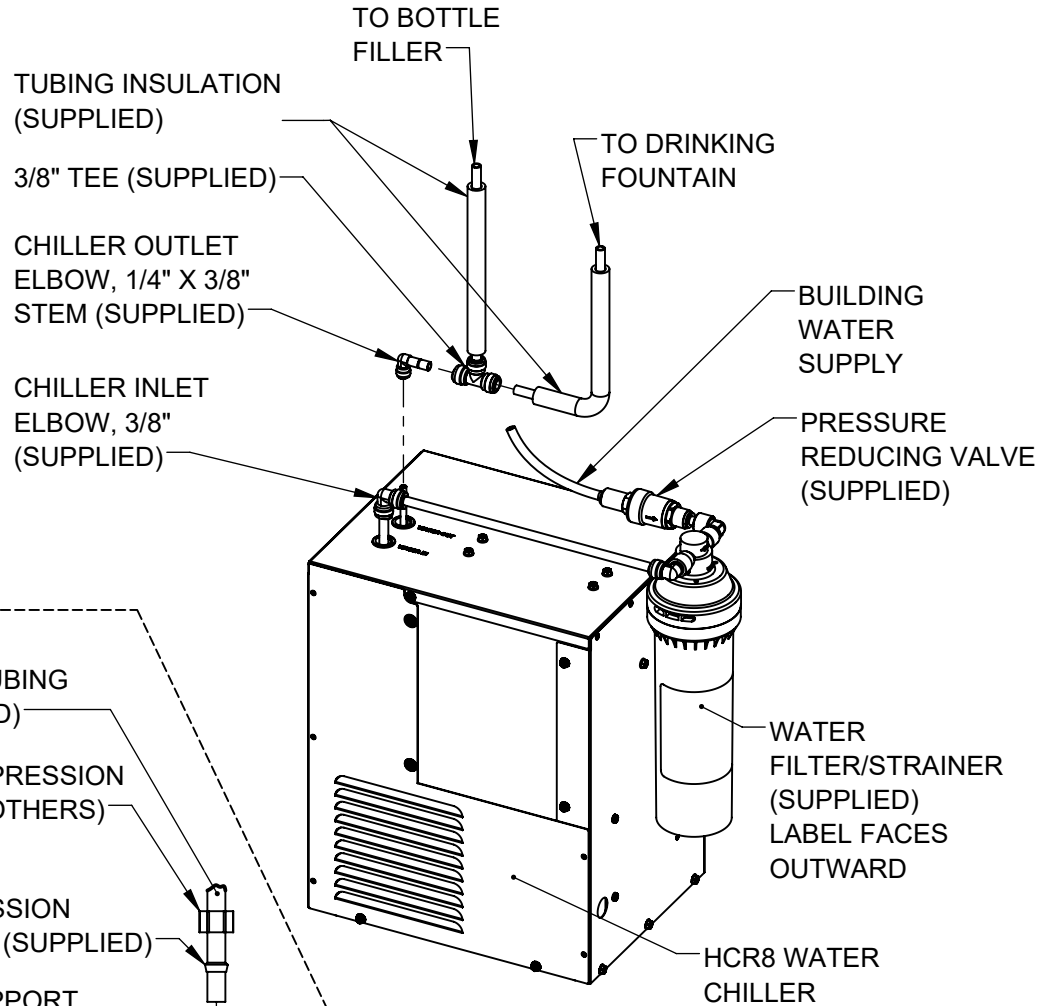

**WATERWAY DIAGRAM**

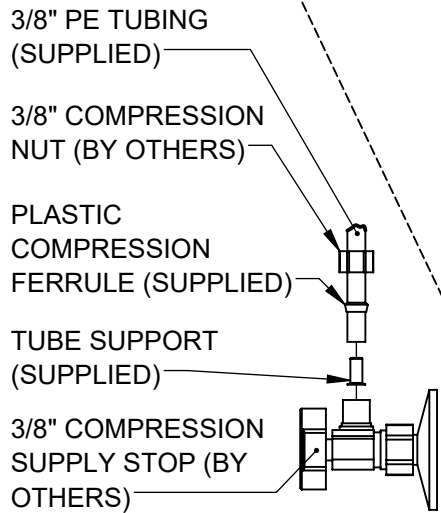

**WATER SUPPLY CONNECTION**

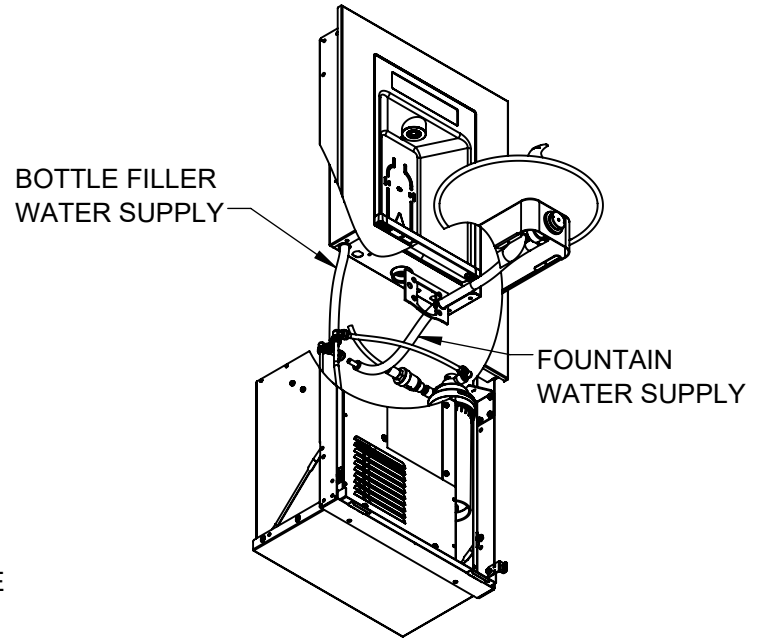

**WATERWAY LAYOUT**  
(SOME COMPONENTS HIDDEN FOR CLARITY)

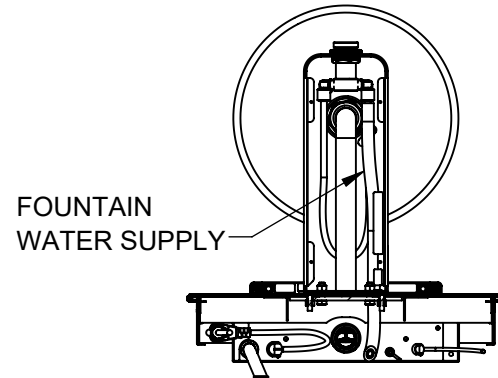

**BOTTOM VIEW**  
(SOME COMPONENTS HIDDEN FOR CLARITY)



1455 KLEPPE LANE  
SPARKS, NEVADA 89431  
(775) 359-4712 FAX (775) 359-7424  
E-MAIL: HAWS@HAWSO.COM  
WEBSITE: WWW.HAWSO.COM

ECN: 6000	REV. ECN: 8000	BY: DHP	MODEL(S) 1X0XHSA.8 & 2000HSA.8, SINGLE AND NO FOUNTAIN MODELS, CHILLED	PART NUMBER 0510002218.D
DRAWN: DHP	DATE: 12/15/22	CHKD: DHP		REVISION 1
APPROVED: JU	DATE: 07/08/24	SCALE: 1:16	DRAWING TYPE: INSTALLATION	SIZE: A

19. CONNECT THE ENERGY SAVINGS RELAY CABLE TO THE ENERGY SAVINGS COAXIAL RECEPTACLE ON THE BOTTLE FILLER.
20. CONNECT THE NEMA 5-15P BOTTLE FILLER PLUG TO THE NEMA 5-15R RECEPTACLE. VERIFY THAT THE BOTTLE FILLER DISPLAY HAS POWERED ON.
21. INSTALL THE FILTER CARTRIDGE INTO THE FILTER HEAD.
22. MOUNT THE LOWER PANEL USING 2X #8 PANEL SCREWS (SUPPLIED).
23. INSTALL DRINKING FOUNTAIN LOWER COVER WITH 4X #8 PAN HEAD SCREWS (SUPPLIED, FOUNTAIN MODELS ONLY).

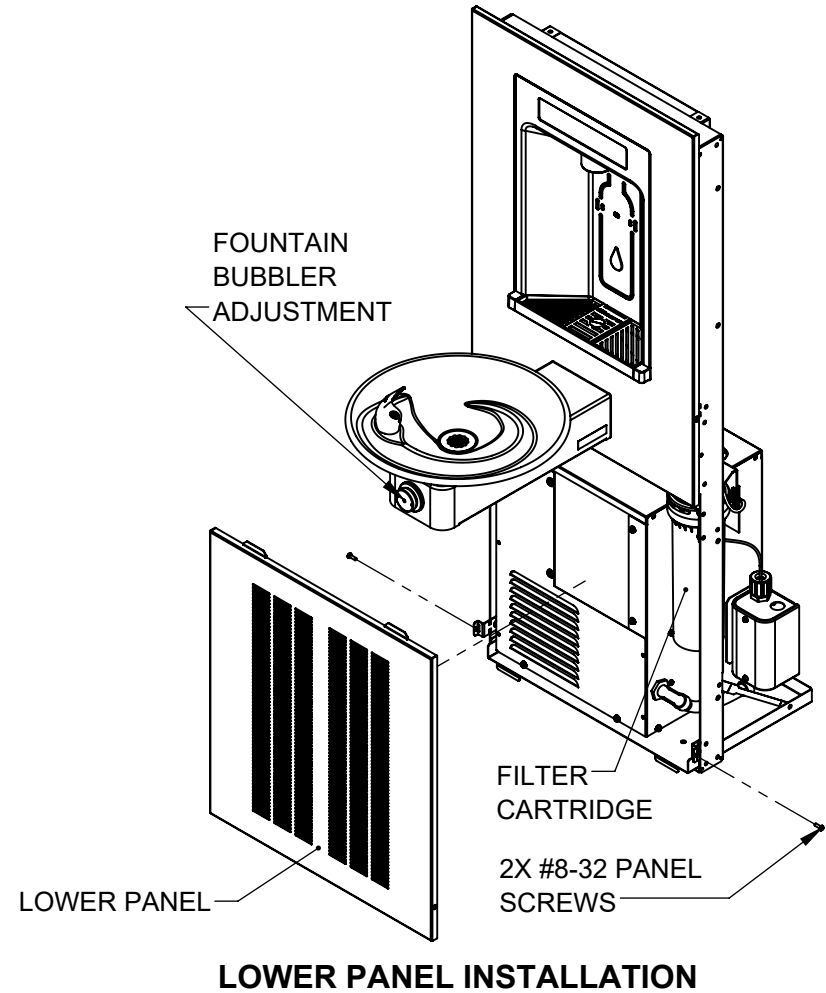
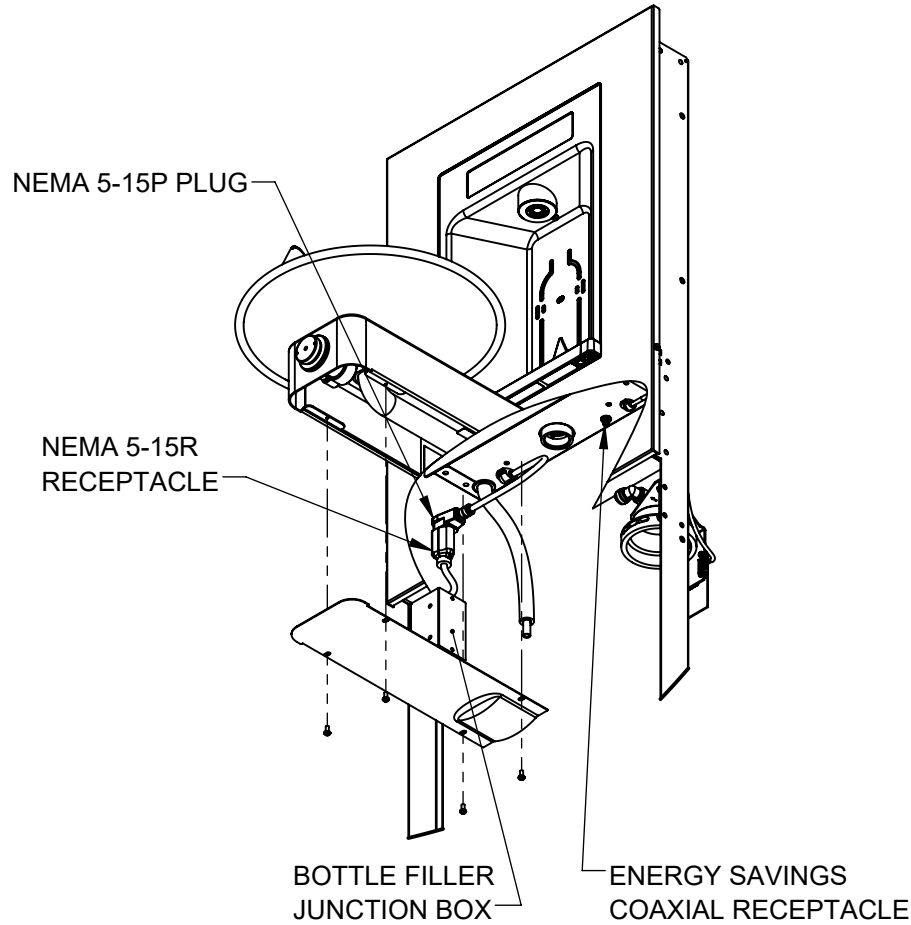

**ELECTRICAL CONNECTIONS AND DRINKING FOUNTAIN LOWER COVER (SOME COMPONENTS HIDDEN FOR CLARITY)**

 <b>Haws</b> Since 1906		1455 KLEPPE LANE SPARKS, NEVADA 89431 (775) 359-4712 FAX (775) 359-7424 E-MAIL: HAWS@HAWS.CO.COM WEBSITE: WWW.HAWS.CO.COM	
		ECN: 6000 REV. ECN: 8000 DRAWN: DHP APPROVED: JU	BY: DHP CHKD: DHP DATE: 12/15/22 DATE: 07/08/24
SCALE: 1:12		DRAWING TYPE: INSTALLATION	
SIZE: A		SHEET 11 OF 11	