

NOTES:

1. HOLD ROUGH-IN DIMENSIONS  $\pm 1/4"$  (6.4mm).
2. WHEN INSTALLING THIS UNIT, LOCAL, STATE, OR FEDERAL CODES SHOULD BE ADHERED TO. INSTALL A TRAP IN THE WASTE LINE AND A SCREWDRIVER STOP IN THE SUPPLY LINE IF REQUIRED.

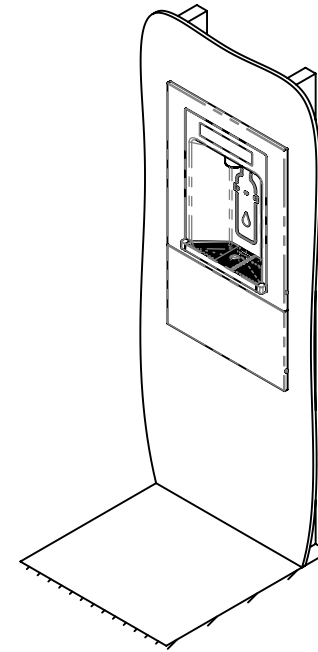
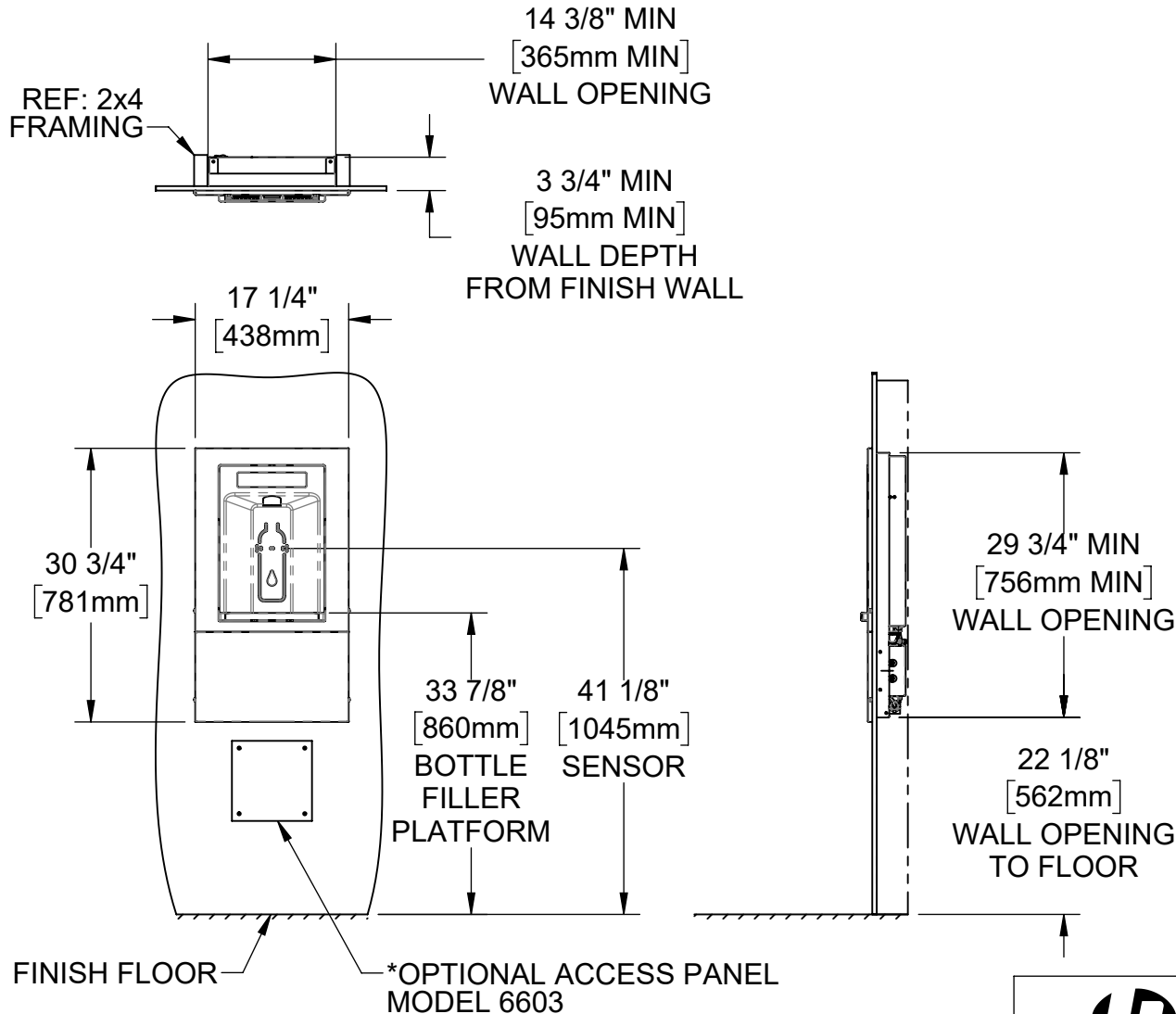

		1455 KLEPPE LANE SPARKS, NEVADA 89431 (775) 359-4712 FAX (775) 359-7424 E-MAIL: HAWS@HAWS.CO.COM WEBSITE: WWW.HAWS.CO.COM	
		ECN: 6000 DRAWN: DHP APPROVED: DHP	REV. ECN: 6000 DATE: 08/16/23 DATE: 08/02/24
PART NUMBER 0510002225.D			REVISION 1
SCALE: 1:20		DRAWING TYPE: INSTALLATION	SIZE: A SHEET 1 OF 7

NOTES:

- ROUGH IN WALL CAVITY WITH DIMENSIONS SHOWN. ROUGH IN ELECTRICAL, WASTE PLUMBING, AND WATER SUPPLY AS REQUIRED.

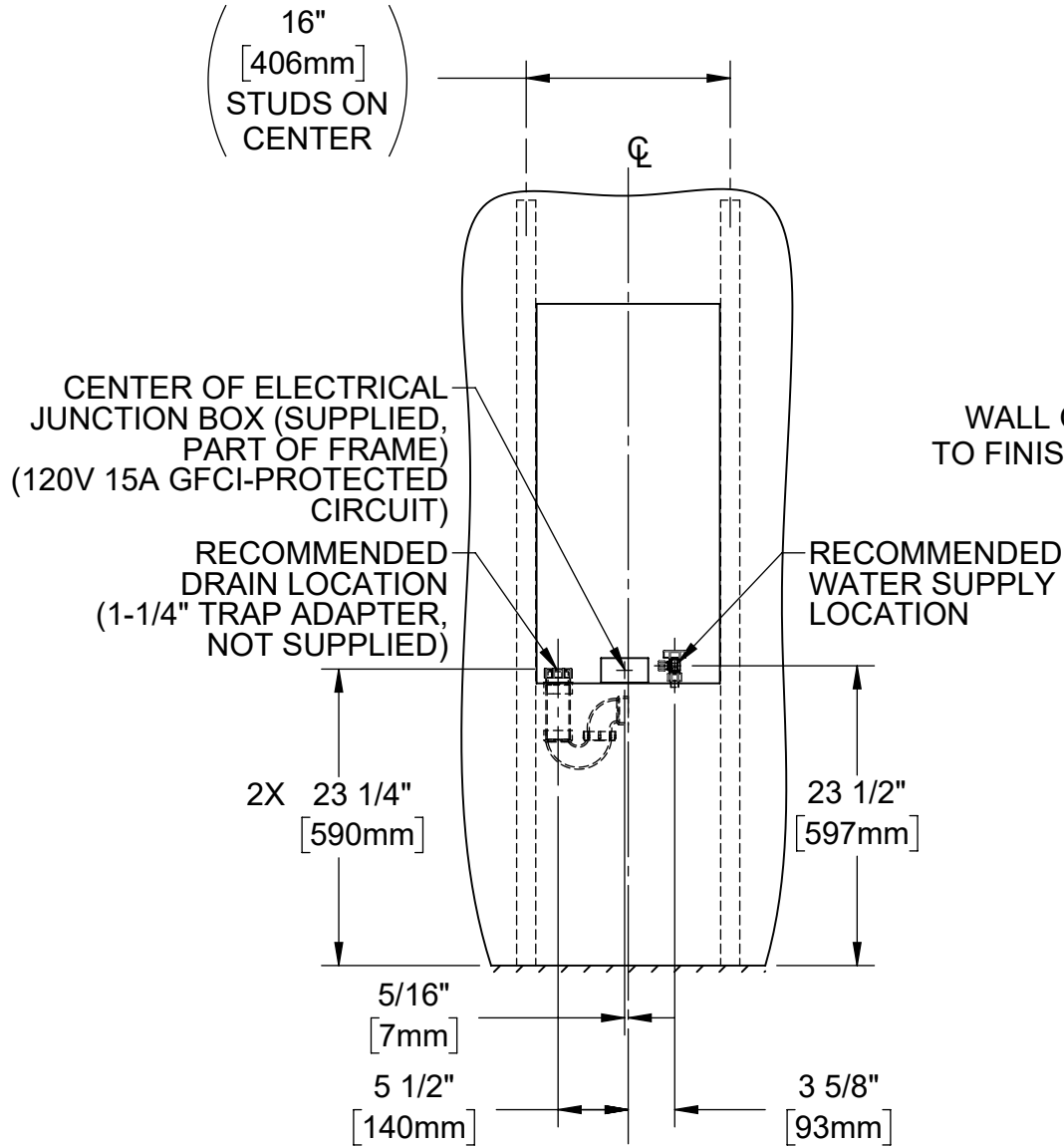

TYPICAL WALL OPENING

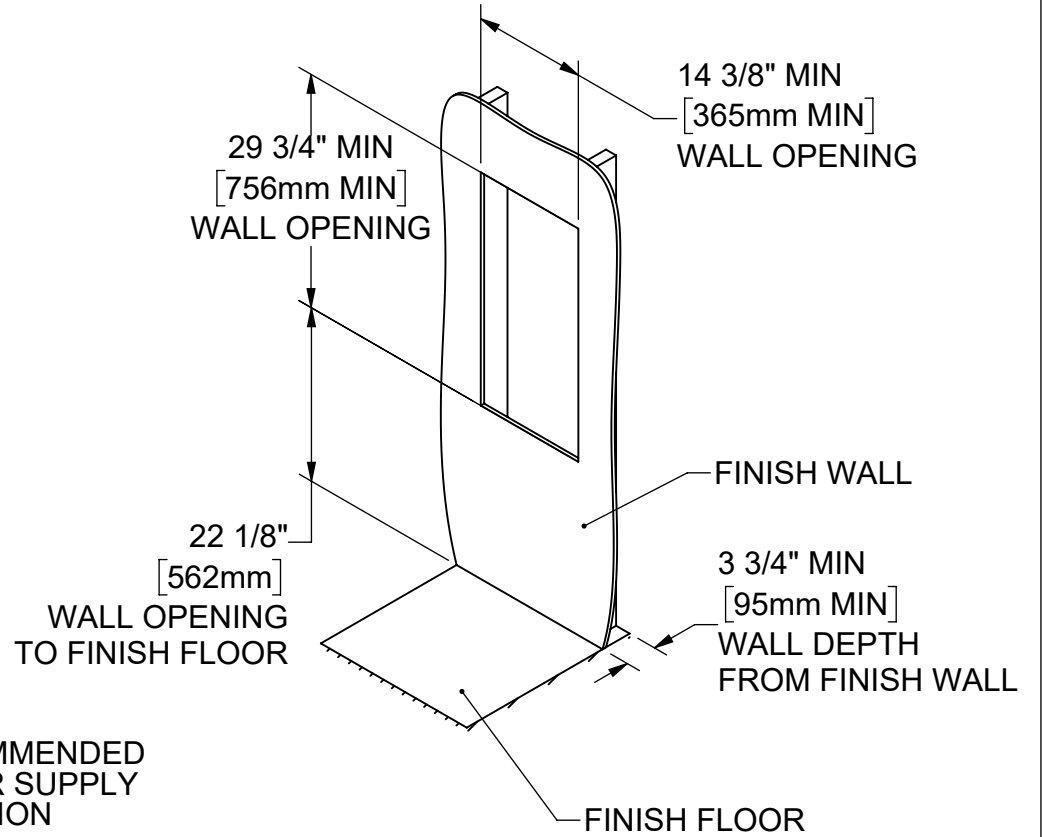

ECN: 6000		REV. ECN: 6000	BY: DHP	MODEL(S)	1455 KLEPPE LANE SPARKS, NEVADA 89431 (775) 359-4712 FAX (775) 359-7424 E-MAIL: HAWS@HAWS.CO.COM WEBSITE: WWW.HAWS.CO.COM	
DRAWN: DHP		DATE: 08/16/23	CHKD: DN	2000HS, BOTTLE FILLER	PART NUMBER: 0510002225.D	
APPROVED: DHP		DATE: 08/02/24			REVISION: 1	
		SCALE: 1:20	DRAWING TYPE: INSTALLATION	SIZE: A		SHEET 2 OF 7

NOTES:

4. DISASSEMBLE BOTTLE FILLER ASSEMBLY AND LOWER PANEL FROM FRAME BY REMOVING 4X #8-32 PANEL SCREWS (T20 TORX).
5. REMOVE WATER FILTER AND SET ASIDE.
6. MOUNT FRAME ASSEMBLY INTO WALL CAVITY USING 6X 1/4" STRUCTURAL SCREWS (NOT SUPPLIED). USE SHIMS AS NEEDED AND ENSURE THE FRAME IS SQUARE.

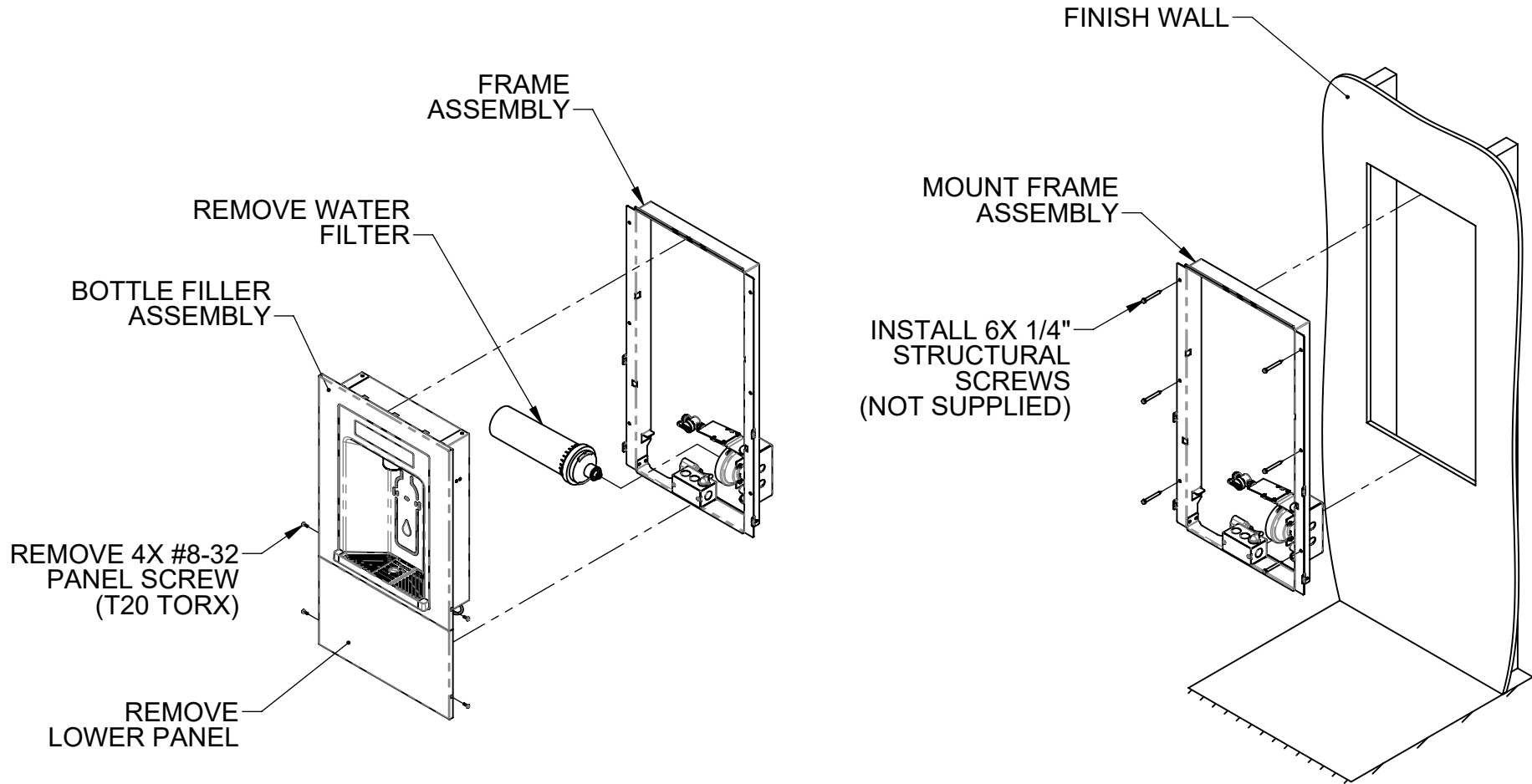

(DRAIN & WATER SUPPLY COMPONENTS HIDDEN FOR CLARITY)

		1455 KLEPPE LANE SPARKS, NEVADA 89431 (775) 359-4712 FAX (775) 359-7424 E-MAIL: HAWS@HAWSO.COM WEBSITE: WWW.HAWSO.COM	
		ECN: 6000 DRAWN: DHP APPROVED: DHP	REV. ECN: 6000 DATE: 08/16/23 DATE: 08/02/24
PART NUMBER 0510002225.D			REVISION 1
SCALE: 1:15		DRAWING TYPE: INSTALLATION	SIZE: A SHEET 3 OF 7

NOTES:

7. HANG BOTTLE FILLER ON TOP OF FRAME. INSTALL 2X #8-32 PANEL SCREWS (PREVIOUSLY REMOVED) ON EITHER SIDE OF THE BOTTLE FILLER PANEL.
8. CONNECT FILTER CABLE TO THE RFID FILTER TRACKING BOARD AND INSERT FILTER CABLE RETAINER INTO FILTER BRACKET (DETAIL B).
9. HAVE AN ELECTRICIAN CONNECT 120V AC (60HZ) 15-AMP GFCI-PROTECTED CIRCUIT TO THE RESPECTIVE LINE, NEUTRAL, AND GROUND CONNECTIONS INSIDE THE BOTTLE FILLER JUNCTION BOX VIA ONE OF THE AVAILABLE 1/2" KNOCKOUTS.

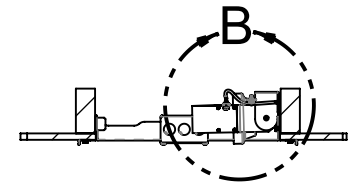

SECTION A-A

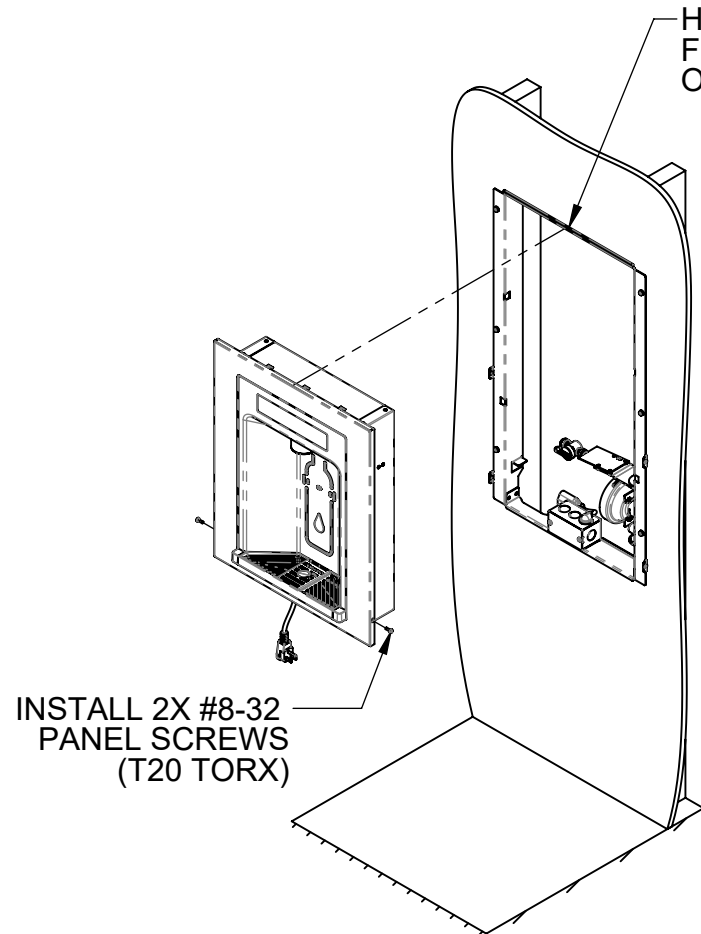

HANG BOTTLE FILLER ON TOP OF FRAME

INSTALL 2X #8-32 PANEL SCREWS (T20 TORX)

CONNECT FILTER CABLE TO RFID BOARD

INSERT FILTER CABLE RETAINER TO FILTER BRACKET

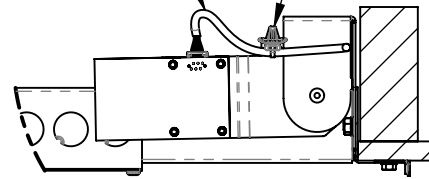

DETAIL B  
FILTER CABLE CONNECTION

CONNECT 120V AC (15A GFCI) TO BOTTLE FILLER JUNCTION BOX (SUPPLIED)

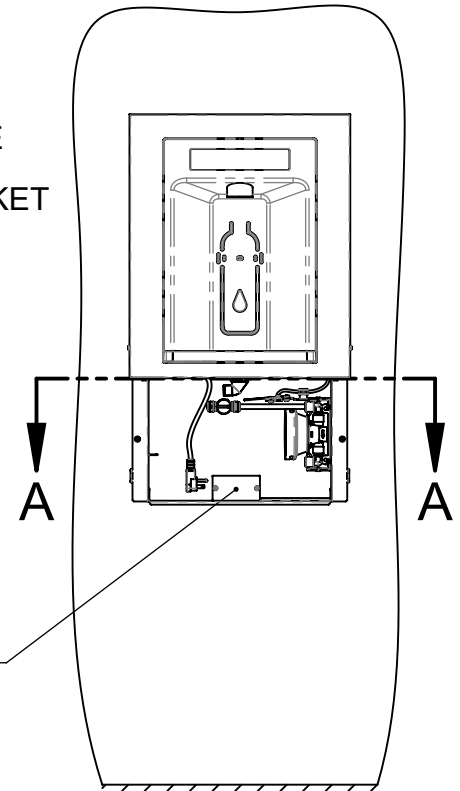

(DRAIN & WATER SUPPLY COMPONENTS HIDDEN FOR CLARITY)

		1455 KLEPPE LANE SPARKS, NEVADA 89431 (775) 359-4712 FAX (775) 359-7424 E-MAIL: HAWS@HAWS.CO.COM WEBSITE: WWW.HAWS.CO.COM			
		ECN: 6000	REV. ECN: 6000	BY: DHP	MODEL(S) 2000HS, BOTTLE FILLER
DRAWN: DHP	DATE: 08/16/23	CHKD: DN		REVISION 1	
APPROVED: DHP	DATE: 08/02/24	SCALE: 1:15	DRAWING TYPE: INSTALLATION	SIZE: A	SHEET 4 OF 7

NOTES:

- 10. ATTACH DRAIN HOSE TO DRAIN STACK USING SUPPLIED DRAIN HOSE ADAPTER AND HOSE CLAMP. ENSURE THAT DRAIN HOSE HAS A DOWNWARD SLOPE ALONG ITS FULL LENGTH.
- 11. ADHERE TO LOCAL, STATE, AND/OR FEDERAL CODES FOR PROPER DRAIN STACK AND TRAP INSTALLATION.

BOTTLE FILLER  
DRAIN ELBOW  
(PRE-INSTALLED)

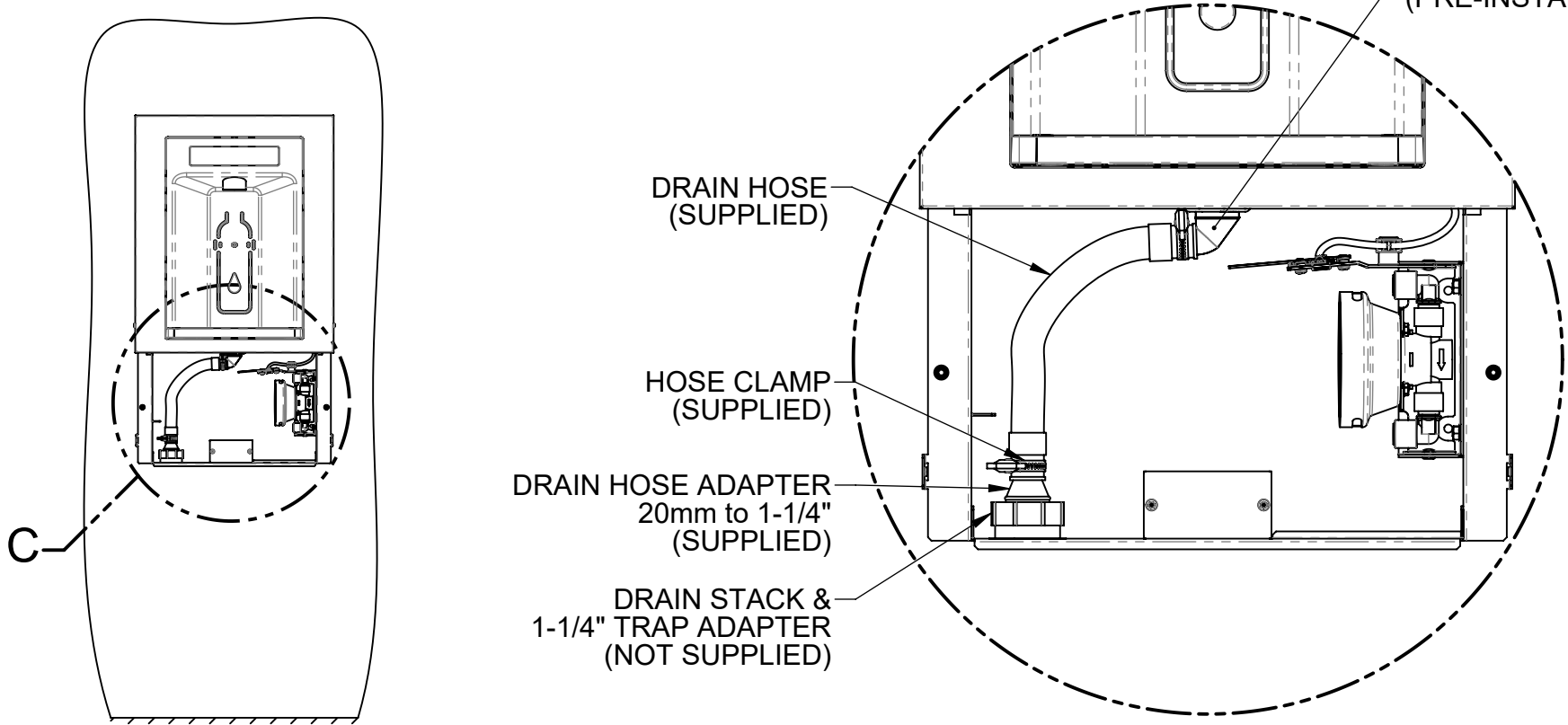

DRAIN HOSE ADAPTER  
20mm to 1-1/4"  
(SUPPLIED)

DRAIN STACK &  
1-1/4" TRAP ADAPTER  
(NOT SUPPLIED)

**DETAIL C**  
(ELECTRICAL AND WATER SUPPLY  
COMPONENTS HIDDEN FOR CLARITY)

**DRAIN HOSE  
ADAPTER  
INSTALLATION**

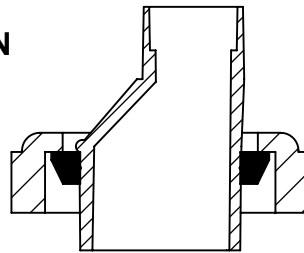
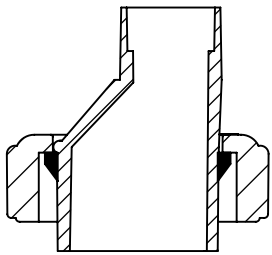

1-1/4" TRAP ADAPTER (NOT SUPPLIED)  
1-1/4" SLIP JOINT WASHER (SUPPLIED)  
1-1/4" NUT (SUPPLIED)

1-1/2" TRAP ADAPTER (NOT SUPPLIED)  
1-1/2" X 1-1/4" SLIP JOINT WASHER (NOT SUPPLIED)  
1-1/2" NUT (NOT SUPPLIED)



1455 KLEPPE LANE  
SPARKS, NEVADA 89431  
(775) 359-4712 FAX (775) 359-7424  
E-MAIL: HAWS@HAWSO.COM  
WEBSITE: WWW.HAWSO.COM

ECN: 6000	REV. ECN: 6000	BY: DHP	MODEL(S) 2000HS, BOTTLE FILLER	PART NUMBER 0510002225.D
DRAWN: DHP	DATE: 08/16/23	CHKD: DN		REVISION 1
APPROVED: DHP	DATE: 08/02/24	SCALE: 1:15	DRAWING TYPE: INSTALLATION	SIZE: A
				SHEET 5 OF 7

NOTES:

12. INSTALL 3/8" TUBING AS SHOWN. NOTE DIRECTION OF FLOW ARROWS ON FILTER. CUT ALL TUBING SQUARE AND CLEAN AS REQUIRED. ENSURE TUBING IS FULLY INSERTED INTO PUSH-TO-CONNECT FITTINGS.
13. CONNECT THE WATER SUPPLY LINE TO THE WATER SUPPLY STOP USING COMPRESSION NUT (INCLUDED WITH YOUR SUPPLY STOP), FOLLOWED BY THE PLASTIC FERRULE (SUPPLIED), AND THE BRASS TUBE SUPPORT (SUPPLIED). INSERT SUPPLY LINE INTO THE SUPPLY STOP UNTIL IT BOTTOMS OUT. THREAD THE NUT ONTO THE SUPPLY STOP UNTIL FINGER TIGHT. PUT A LINE ON THE NUT USING A MARKER. TIGHTEN EXACTLY ONE ADDITIONAL FULL TURN (360 DEG) WITH A WRENCH, USING THE LINE TO COUNT TURNS. \*NOTE THE CORRECT ORIENTATION OF THE PLASTIC FERRULE. \*DO NOT USE THE BRASS FERRULE INCLUDED WITH YOUR SUPPLY VALVE.

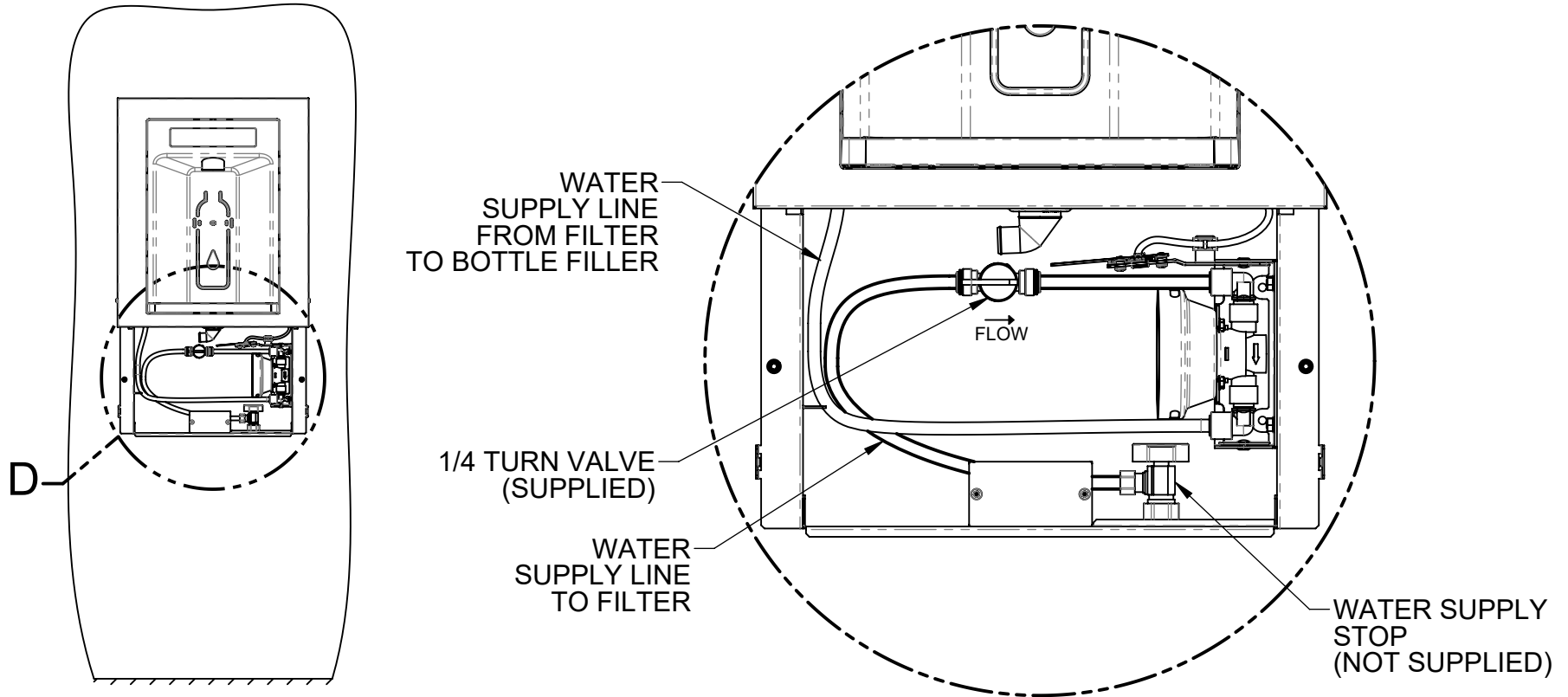

WATER SUPPLY LINE FROM FILTER TO BOTTLE FILLER

FLOW

1/4 TURN VALVE (SUPPLIED)

WATER SUPPLY LINE TO FILTER

WATER SUPPLY STOP (NOT SUPPLIED)

D

DETAIL D

(DRAIN & ELECTRICAL COMPONENTS HIDDEN FOR CLARITY)

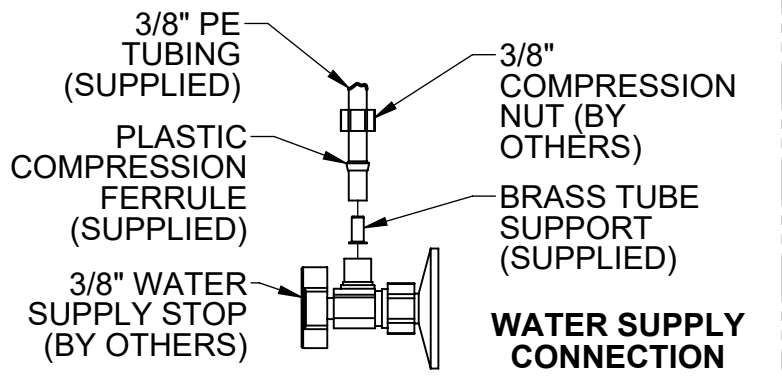

3/8" PE TUBING (SUPPLIED)

3/8" COMPRESSION NUT (BY OTHERS)

PLASTIC COMPRESSION FERRULE (SUPPLIED)

BRASS TUBE SUPPORT (SUPPLIED)

3/8" WATER SUPPLY STOP (BY OTHERS)

WATER SUPPLY CONNECTION

		1455 KLEPPE LANE SPARKS, NEVADA 89431 (775) 359-4712 FAX (775) 359-7424 E-MAIL: HAWS@HAWS.CO.COM WEBSITE: WWW.HAWS.CO.COM			
		ECN: 6000 REV. ECN: 6000 DRAWN: DHP APPROVED: DHP	BY: DHP DATE: 08/16/23 CHKD: DN DATE: 08/02/24	MODEL(S) 2000HS, BOTTLE FILLER	PART NUMBER 0510002225.D REVISION 1
© 2024 Haws Corporation - All Rights Reserved. HAWS® and other trademarks used in these materials are the exclusive property of Haws Corporation.		SCALE: 1:15	DRAWING TYPE: INSTALLATION	SIZE: A	SHEET 6 OF 7

NOTES:

14. INSTALL WATER FILTER AND TURN ON WATER SUPPLY.
15. CHECK ALL FITTINGS FOR LEAKS AND ENSURE DRAIN FITTINGS ARE TIGHT.
16. CONNECT BOTTLE FILLER POWER CORD PLUG TO JUNCTION BOX POWER CORD RECEPTACLE.
17. INSTALL LOWER PANEL USING 2X #8-32 PANEL SCREWS (PREVIOUSLY REMOVED).
18. INSTALLATION COMPLETE.

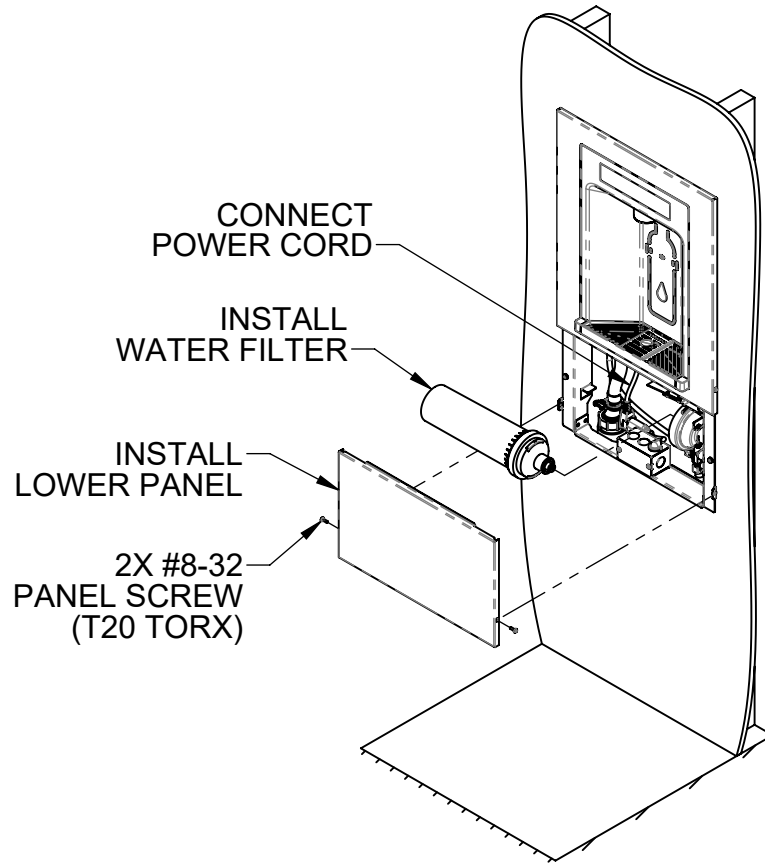

			1455 KLEPPE LANE SPARKS, NEVADA 89431 (775) 359-4712 FAX (775) 359-7424 E-MAIL: HAWS@HAWS.CO.COM WEBSITE: WWW.HAWS.CO.COM		
			ECN: 6000	REV. ECN: 6000	BY: DHP
DRAWN: DHP	DATE: 08/16/23	CHKD: DN			REVISION 1
APPROVED: DHP	DATE: 08/02/24	SCALE: 1:15	DRAWING TYPE: INSTALLATION	SIZE: A	SHEET 7 OF 7