

**NOTES:**

- HOLD ROUGH-IN DIMENSIONS  $\pm 1/4"$  (6.4mm).
- WHEN INSTALLING THIS UNIT, LOCAL, STATE, OR FEDERAL CODES SHOULD BE ADHERED TO. INSTALL A TRAP IN THE WASTE LINE AND A SCREWDRIVER STOP IN THE SUPPLY LINE IF REQUIRED.

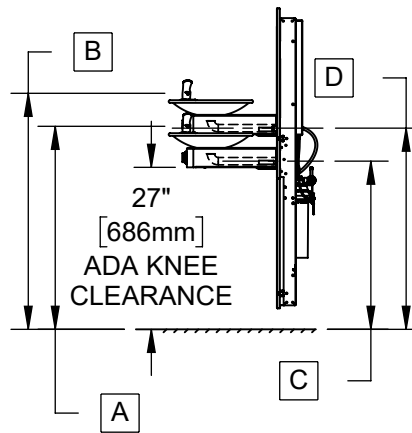

**1011HSA**

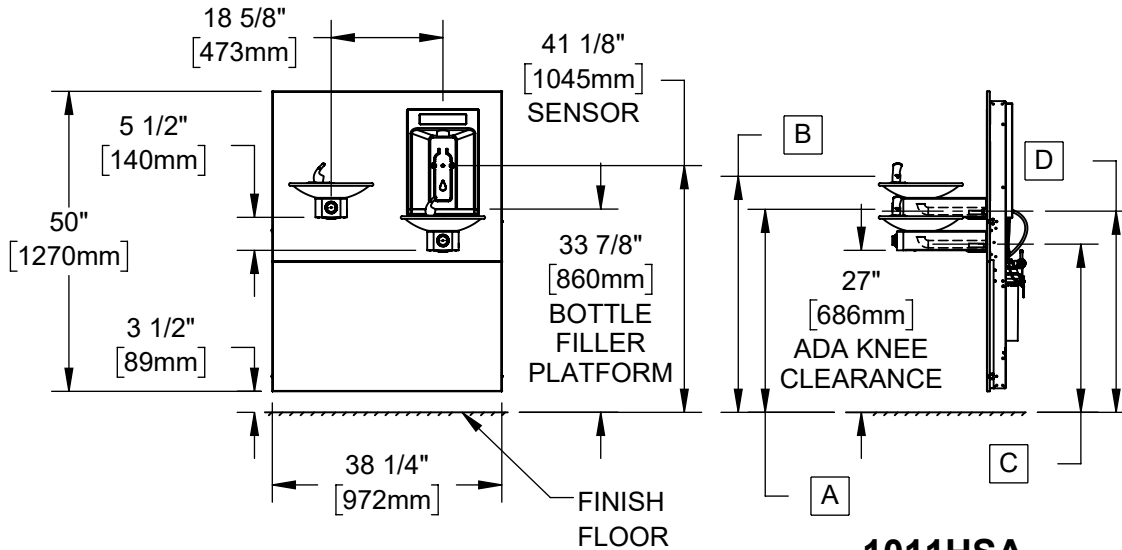
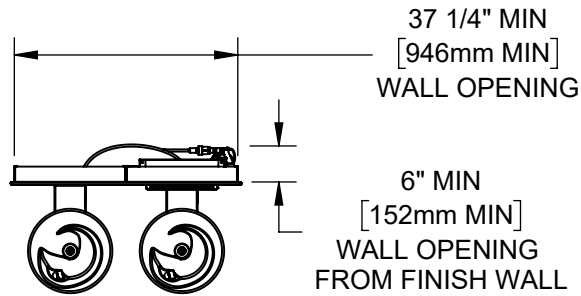
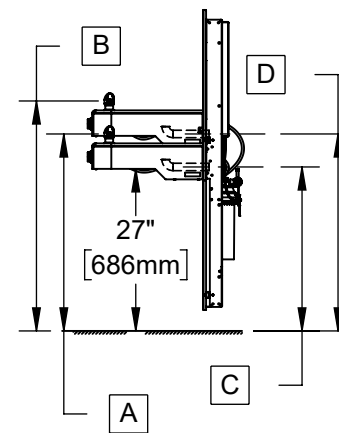

**1117HSA**

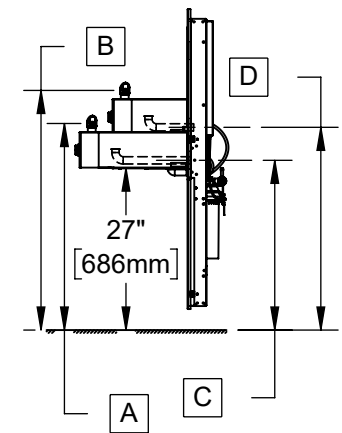

**1119HSA**

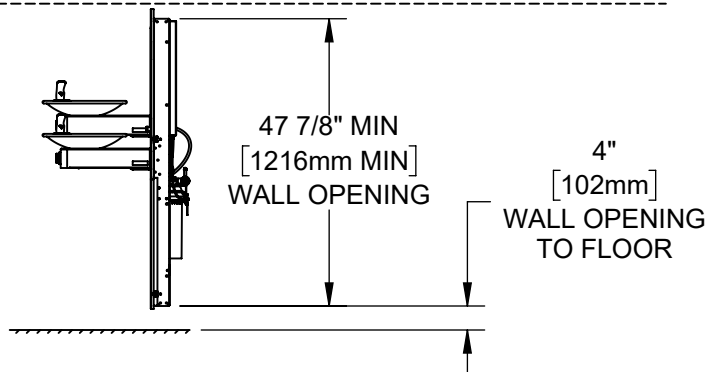

	A	B	C	D	
FOUNTAIN MODELS	LOW SIDE BUBBLER	HIGH SIDE BUBBLER	LOW SIDE DRAIN	HIGH SIDE DRAIN	WASTE BEND SIZE
1001/1011	33 13/16" [858mm]	39 5/16" [998mm]	28" [711mm]	33 1/2" [851mm]	1-1/4"
1107/1117	32 13/16" [834mm]	38 5/16" [974mm]	27 5/16" [694mm]	32 13/16" [834mm]	1-1/4"
1109/1119	34 7/16" [875mm]	39 15/16" [1014mm]	28 1/4" [718mm]	33 3/4" [857mm]	1-1/4"

1455 KLEPPE LANE  
SPARKS, NEVADA 89431  
(775) 359-4712 FAX (775) 359-7424  
E-MAIL: HAWS@HAWS.CO.COM  
WEBSITE: WWW.HAWS.CO.COM

ECN: 6000	REV. ECN: 6000	BY: DHP	MODEL(S)	PART NUMBER
DRAWN: DHP	DATE: 12/15/22	CHKD: DHP	1XXXHSA, DUAL FOUNTAIN MODELS	0510002202.D
APPROVED: JU	DATE: 07/08/24	SCALE: 1:32	DRAWING TYPE: INSTALLATION	REVISION: 1
			SIZE: A	SHEET 1 OF 11

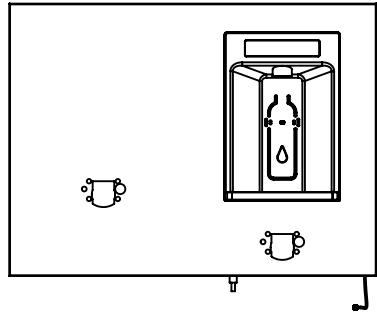

BOTTLE FILLER  
(HS4 SHOWN FOR REFERENCE)

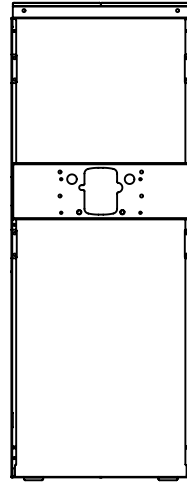

HIGH SIDE FRAME  
(0410000901)

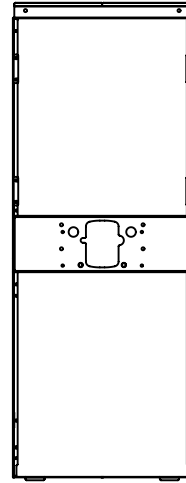

LOW SIDE FRAME (HS11)

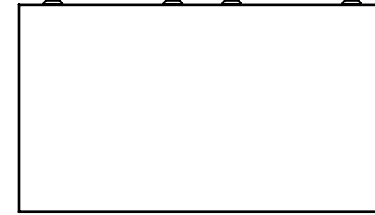

LOWER PANEL  
(0410000923)

HS12



1011 FOUNTAIN (2X, HS7)

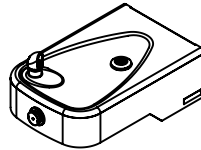

1117 FOUNTAIN (2X, HS8)

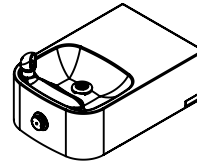

1119 LOW SIDE FOUNTAIN (HS9)

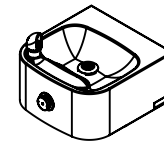

1119 HIGH SIDE FOUNTAIN (HS10)

HS MODEL #	BOTTLE FILLER	LOW SIDE FRAME	HIGH SIDE FRAME	LOW SIDE FOUNTAIN	HIGH SIDE FOUNTAIN	LOWER PANEL	LOOSE PARTS KIT
1011HSA	HS4	HS11	0410000901	HS7	HS7	0410000923	HS103
1117HSA	HS6	HS11	0410000901	HS8	HS8	0410000923	HS103
1119HSA	HS6	HS11	0410000901	HS9	HS10	0410000923	HS103



**Haws**  
Since 1906

1455 KLEPPE LANE  
SPARKS, NEVADA 89431  
(775) 359-4712 FAX (775) 359-7424  
E-MAIL: HAWS@HAWS.CO.COM  
WEBSITE: WWW.HAWS.CO.COM

ECN: 6000	REV. ECN: 6000	BY: DHP	MODEL(S)	PART NUMBER
DRAWN: DHP	DATE: 12/15/22	CHKD: DHP	1XXXHSA, DUAL FOUNTAIN MODELS	0510002202.D
APPROVED: JU	DATE: 07/08/24			REVISION
				1
		SCALE: 1:20	DRAWING TYPE: INSTALLATION	SIZE: A
				SHEET 2 OF 11

3. ROUGH IN WALL CAVITY WITH DIMENSIONS SHOWN. ROUGH IN ELECTRICAL, WASTE PIPING, AND WATER SUPPLY AS REQUIRED. BE SURE ELECTRICAL, WASTE PIPING, AND WATER SUPPLY IS CLEAR OF THE INSTALLED LOCATION OF THE IN WALL FRAME, AND BOTTLE FILLER.

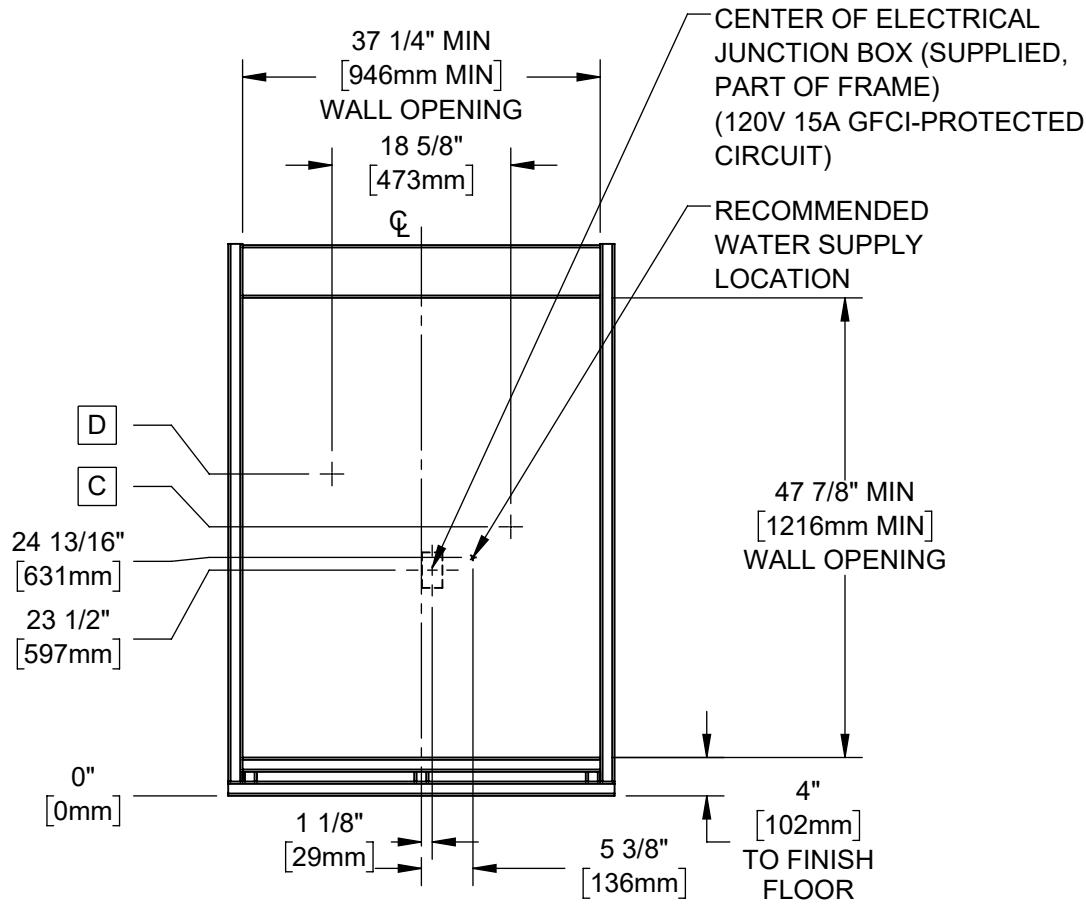

**TYPICAL WALL OPENING**

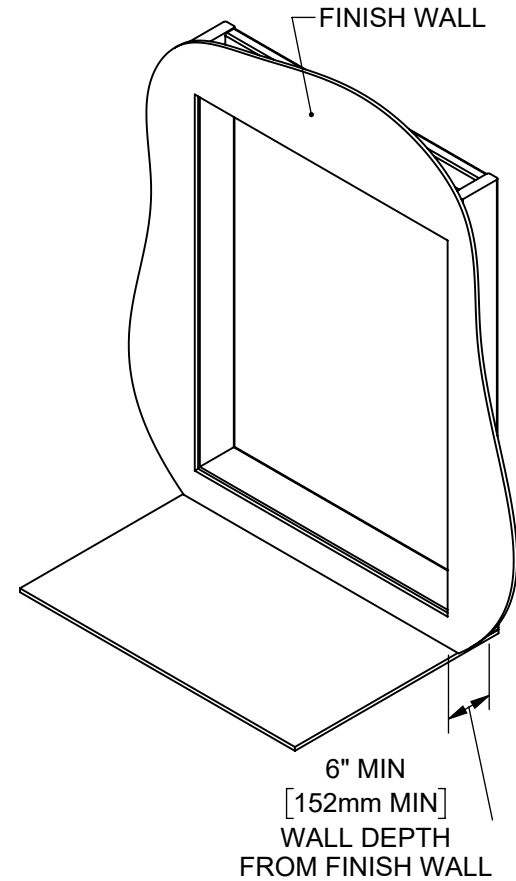

	C	D	
<b>FOUNTAIN MODELS</b>	<b>LOW SIDE DRAIN</b>	<b>HIGH SIDE DRAIN</b>	<b>WASTE BEND SIZE</b>
1001/1011	28" [711mm]	33 1/2" [851mm]	1-1/4"
1107/1117	27 5/16" [694mm]	32 13/16" [834mm]	1-1/4"
1109/1119	28 1/4" [718mm]	33 3/4" [857mm]	1-1/4"



**Haws**<sup>®</sup>

Since 1906

1455 KLEPPE LANE  
SPARKS, NEVADA 89431  
(775) 359-4712 FAX (775) 359-7424  
E-MAIL: HAWS@HAWSO.COM  
WEBSITE: WWW.HAWSO.COM

ECN: 6000	REV. ECN: 6000	BY: DHP	MODEL(S) 1XXXHSA, DUAL FOUNTAIN MODELS	PART NUMBER 0510002202.D
DRAWN: DHP	DATE: 12/15/22	CHKD: DHP		REVISION 1
APPROVED: JU	DATE: 07/08/24	SCALE: 1:20	DRAWING TYPE: INSTALLATION	SIZE: A

SHEET 3 OF 11

4. BOLT FRAMES TOGETHER USING 4X 5/16" BOLTS AND NUTS AS SHOWN (DETAIL A). INSTALL 4X PANEL CLIPS (DETAIL B) USING #10 NUTS (SUPPLIED).
5. MOUNT FRAME ASSEMBLY INTO WALL CAVITY USING 16X STRUCTURAL SCREWS (NOT SUPPLIED), USE SHIMS AS NEEDED AND ENSURE THE FRAME IS SQUARE.

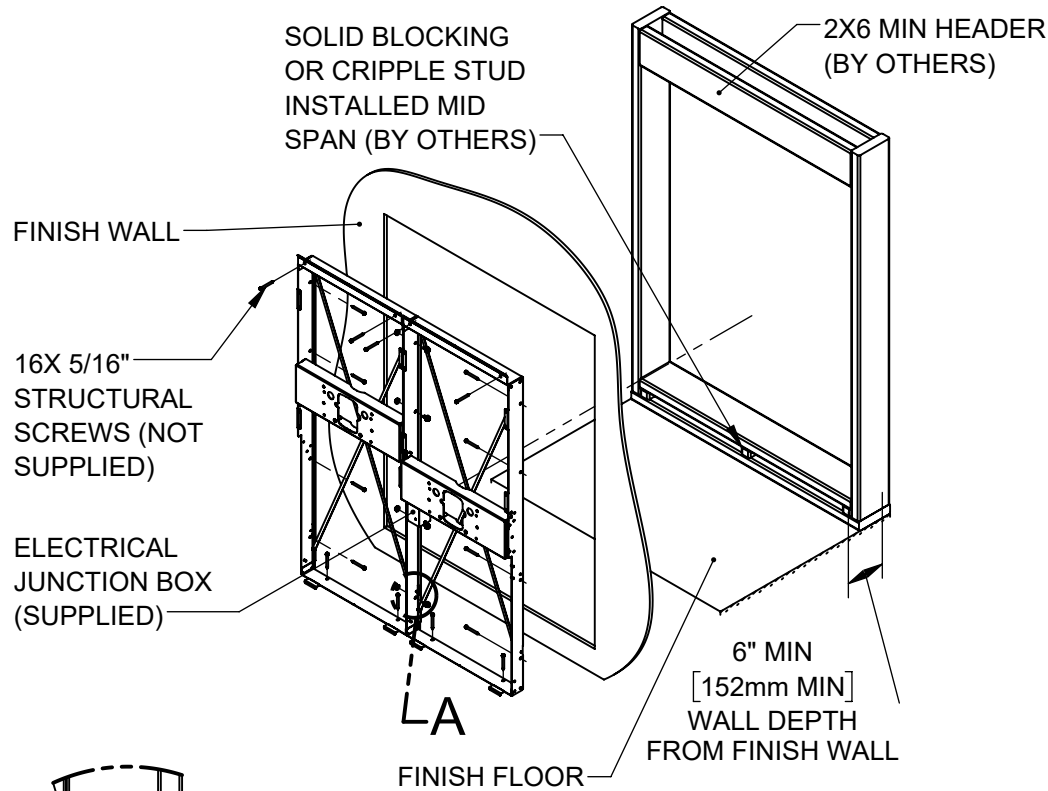

**FRAME INSTALLATION**

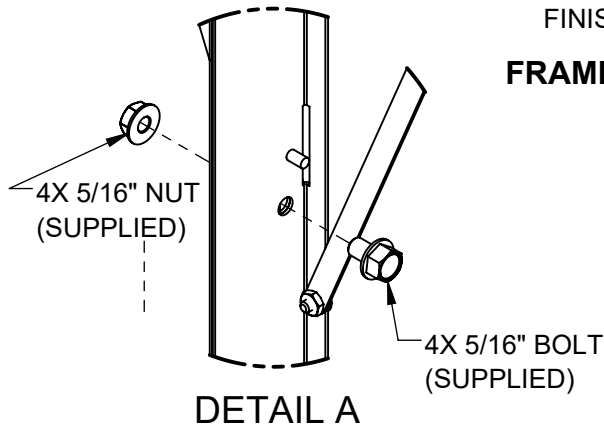

**DETAIL A**

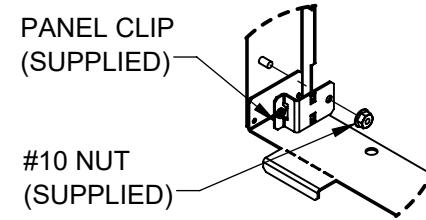

**DETAIL B  
PANEL CLIP  
INSTALL  
(4 PLACES)**

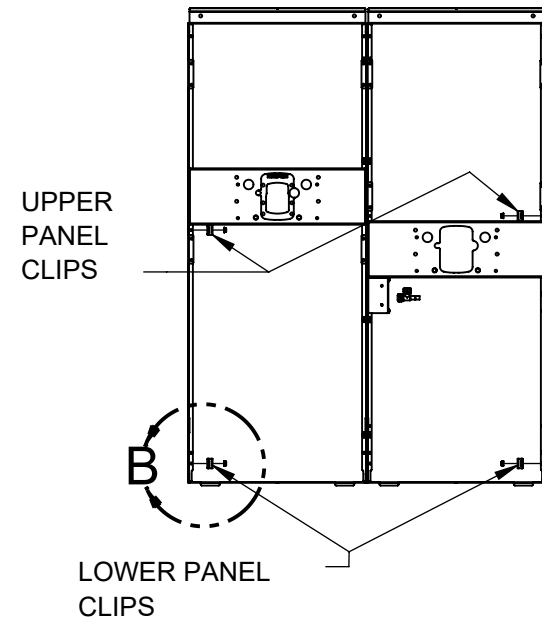

**PANEL CLIP INSTALLATION**

		1455 KLEPPE LANE SPARKS, NEVADA 89431 (775) 359-4712 FAX (775) 359-7424 E-MAIL: HAWS@HAWSO.COM WEBSITE: WWW.HAWSO.COM	
ECN: 6000	REV. ECN: 6000	BY: DHP	MODEL(S) 1XXXHSA, DUAL FOUNTAIN MODELS
DRAWN: DHP	DATE: 12/15/22	CHKD: DHP	PART NUMBER 0510002202.D
APPROVED: JU	DATE: 07/08/24	SCALE: 1:20	REVISION 1
DRAWING TYPE: INSTALLATION		SIZE: A	SHEET 4 OF 11

6. REMOVE SHIPPING BRACKETS FROM RIGHT AND LEFT FRAME (DETAIL C).
7. INSTALL FILTER HEAD USING 3X SUPPLIED #10 NUTS (DETAIL D).
8. (1011HSA ONLY) INSTALL 1001 DRINKING FOUNTAIN ADAPTERS USING 2X SUPPLIED 3/8" NUTS (DETAIL E). ENSURE THE CORRECT ORIENTATION OF THE ADAPTER PLATE, "FRONT" IS PRINTED ON THE ADAPTER PLATE AND SHOULD BE ORIENTED TOWARDS THE FINISH WALL.

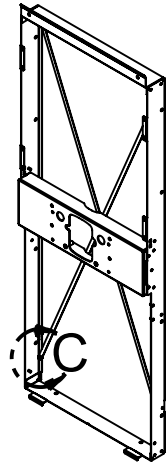

REMOVE SHIPPING  
CROSS BRACING

**DETAIL C**  
(4 PLACES)

**SHIPPING CROSS  
BRACE REMOVAL**

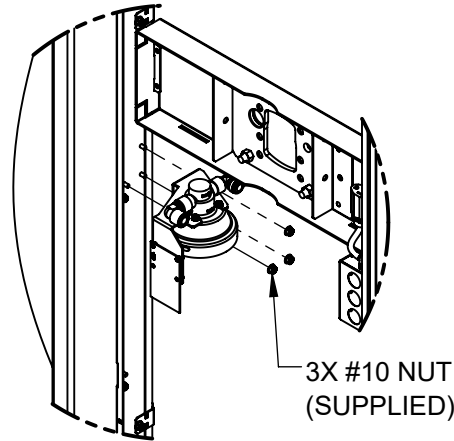

**DETAIL D**  
FILTER/STRAINER HEAD INSTALL  
(ALL MODELS)

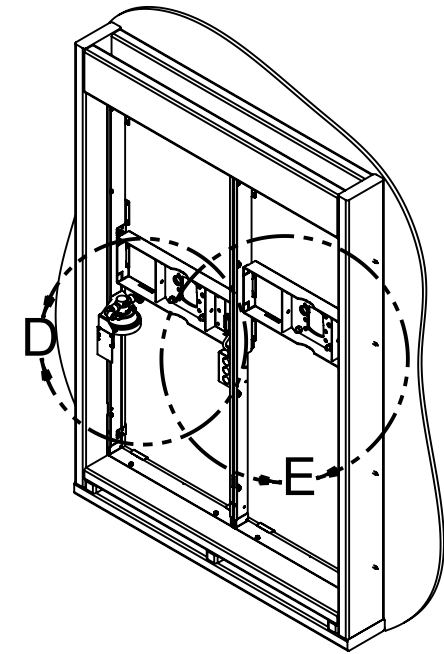

**REAR VIEW**

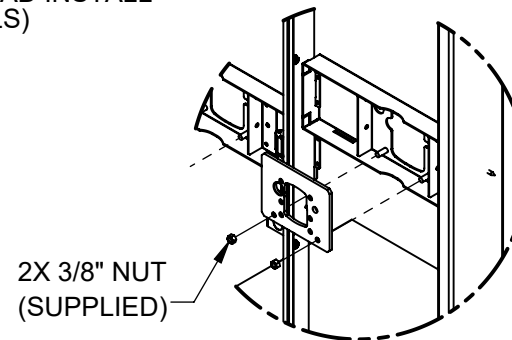

**DETAIL E**  
1001 FOUNTAIN ADAPTER PLATE (1001/1011  
MODELS ONLY)



1455 KLEPPE LANE  
SPARKS, NEVADA 89431  
(775) 359-4712 FAX (775) 359-7424  
E-MAIL: HAWS@HAWSO.COM  
WEBSITE: WWW.HAWSO.COM

ECN: 6000	REV. ECN: 6000	BY: DHP	MODEL(S) 1XXXHSA, DUAL FOUNTAIN MODELS	PART NUMBER 0510002202.D
DRAWN: DHP	DATE: 12/15/22	CHKD: DHP		REVISION 1
APPROVED: JU	DATE: 07/08/24	SCALE: 1:20	DRAWING TYPE: INSTALLATION	SIZE: A

9. INSTALL 8X 3/8" DRINKING FOUNTAIN BOLTS (SUPPLIED) FROM THE BACK SIDE OF THE FRAME.
10. HANG THE BOTTLE FILLER FROM THE TOP OF THE FRAME AND ALIGN THE PANEL SO THE 3/8" DRINKING FOUNTAIN BOLTS PROTRUDE THROUGH THE PANEL. INSTALL THE 2X #8 PANEL SCREWS (SUPPLIED) ON EITHER SIDE OF THE BOTTLE FILLER PANEL.
11. CONNECT THE FILTER CABLE (RIGHT SIDE OF THE BOTTLE FILLER) TO THE FILTER TRACKING BOARD.

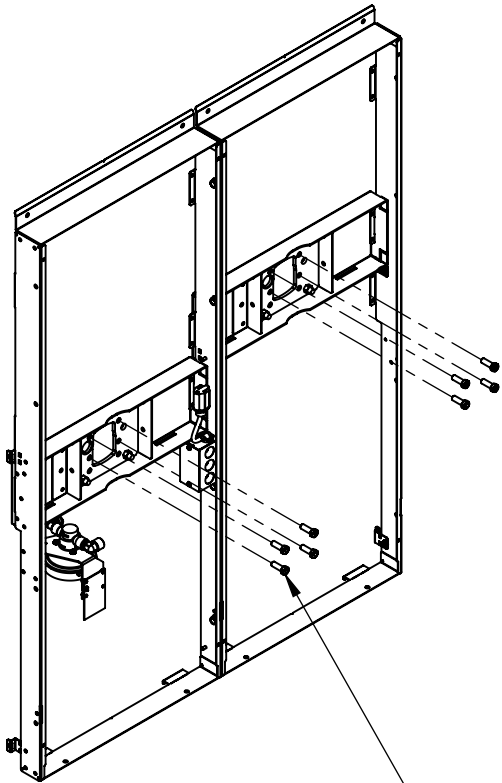

8X DRINKING FOUNTAIN BOLTS (SUPPLIED). USE WASHERS (SUPPLIED) UNDER HEAD OF BOLTS FOR 1107/1117 AND 1109/1119 MODELS

**REAR VIEW**

2X #8-32 BUTTON HEAD PANEL SCREWS (SUPPLIED)

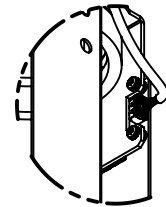
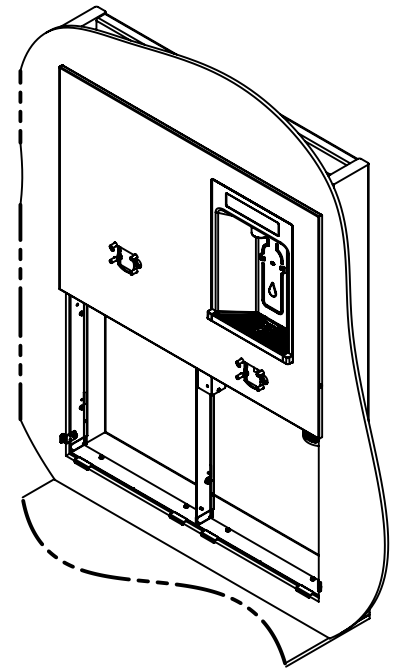
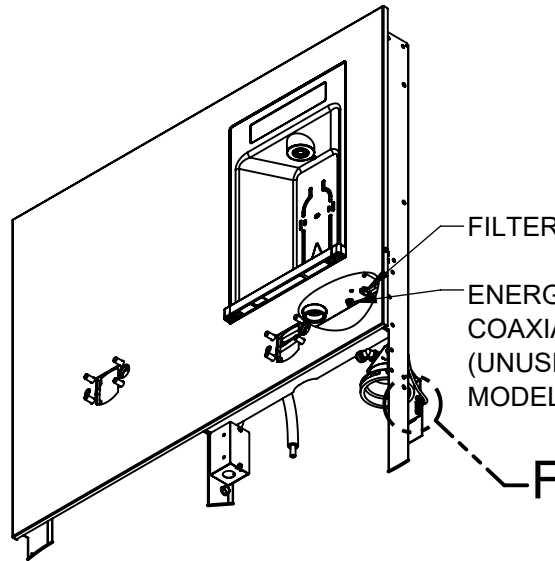
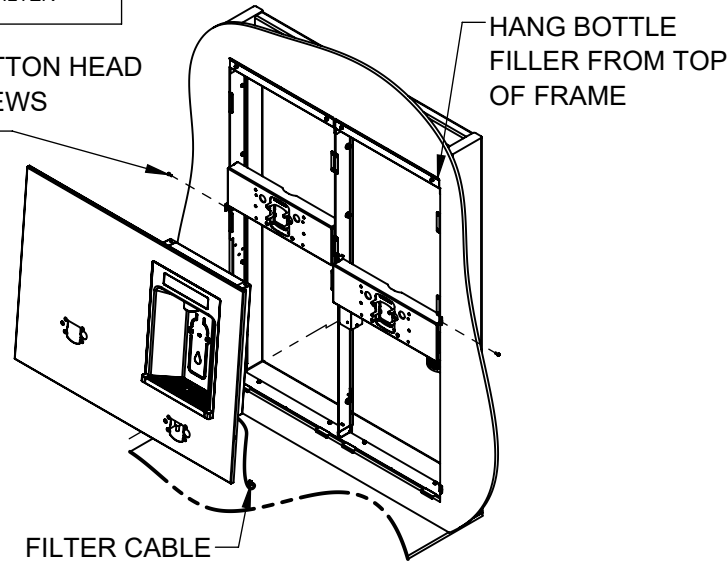

**DETAIL F**  
FILTER TRACKING  
ELECTRICAL CONNECTION

 <b>Haws</b> Since 1906		1455 KLEPPE LANE SPARKS, NEVADA 89431 (775) 359-4712 FAX (775) 359-7424 E-MAIL: HAWS@HAWSO.COM WEBSITE: WWW.HAWSO.COM	
		ECN: 6000 REV. ECN: 6000 DRAWN: DHP APPROVED: JU	BY: DHP DATE: 12/15/22 DATE: 07/08/24
SCALE: 1:14		DRAWING TYPE: INSTALLATION	
SIZE: A		SHEET 6 OF 11	

NOTE: STEP 12 CAN BE PERFORMED LATER IN INSTALLATION IF DESIRED.

12. HAVE AN ELECTRICIAN CONNECT A 120VAC/60HZ 15-AMP GFCI-PROTECTED CIRCUIT TO THE RESPECTIVE LINE, NEUTRAL, AND GROUND CONNECTIONS INSIDE THE BOTTLE FILLER JUNCTION BOX VIA ONE OF THE AVAILABLE 1/2" KNOCKOUTS.

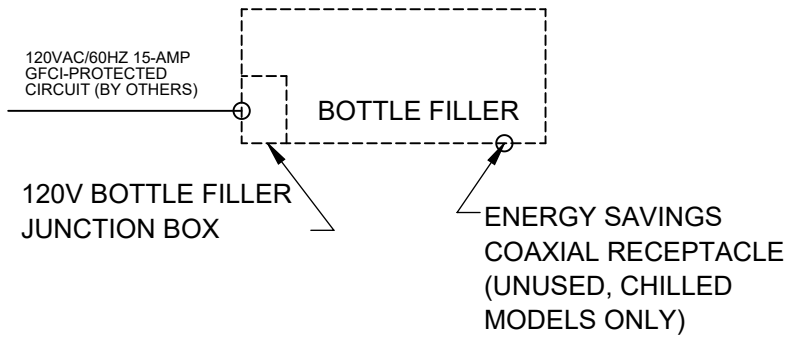

**ELECTRICAL WIRING OVERVIEW**

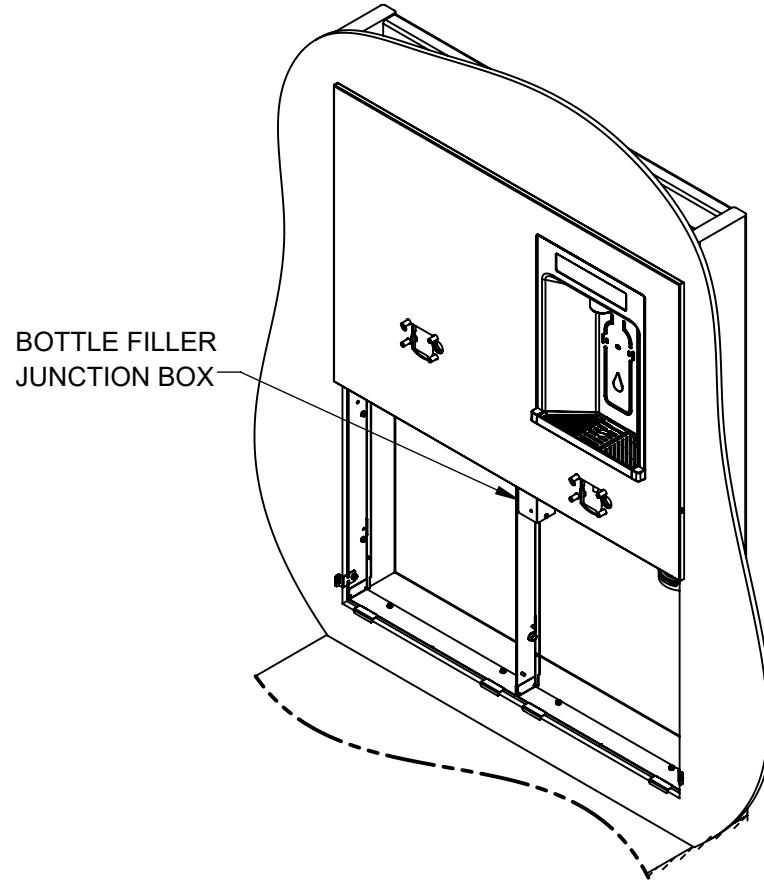

 <b>Haws</b> Since 1906			1455 KLEPPE LANE SPARKS, NEVADA 89431 (775) 359-4712 FAX (775) 359-7424 E-MAIL: HAWS@HAWSO.COM WEBSITE: WWW.HAWSO.COM		
ECN: 6000	REV. ECN: 6000	BY: DHP	MODEL(S) 1XXXHSA, DUAL FOUNTAIN MODELS		PART NUMBER 0510002202.D
DRAWN: DHP	DATE: 12/15/22	CHKD: DHP			REVISION 1
APPROVED: JU	DATE: 07/08/24	SCALE: 1:20	DRAWING TYPE: INSTALLATION	SIZE: A	SHEET 7 OF 11

13. MOUNT THE DRINKING FOUNTAIN TO THE PROTRUDING 3/8" STUDS FROM STEP 9. INSTALL 4X 3/8" NUTS (SUPPLIED) PER DRINKING FOUNTAIN AND TIGHTEN FULLY (25 LB-FT).
14. INSTALL THE WASTE BEND (SUPPLIED), CUT TO LENGTH AS REQUIRED. REFER TO SHEET 3 FOR DRAIN HEIGHTS FOR EACH MODEL. SET LOWER COVER AND #8 PAN HEAD SCREWS ASIDE, THESE WILL BE INSTALLED ONCE THE WATER SUPPLY PLUMBING IS COMPLETE.

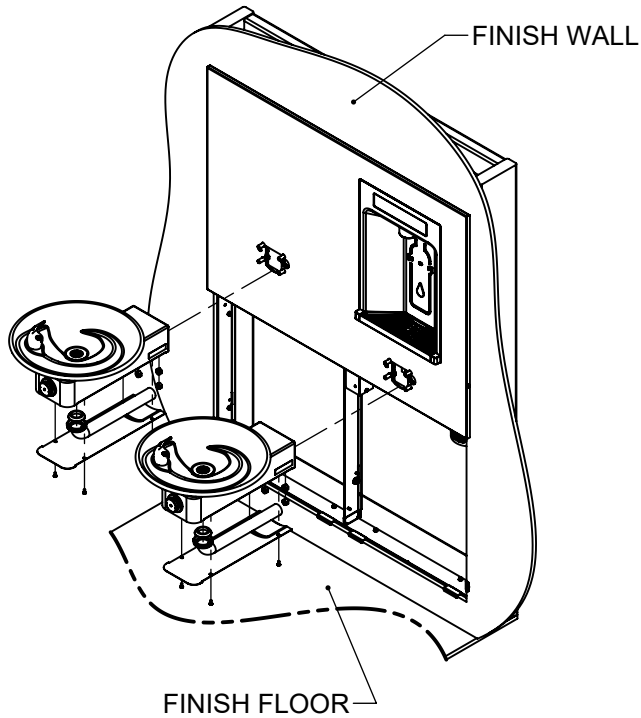

WATER SUPPLY BUSHING (SUPPLIED)

DRAIN WASHER (SUPPLIED)

NUT (SUPPLIED)

LOWER COVER (SUPPLIED)

1-1/4" WASTE BEND (SUPPLIED)

#8-32 PAN HEAD SCREWS (SUPPLIED)

- 1011HSA - 4X
- 1117HSA - 8X
- 1119HSA - 6X

DRINKING FOUNTAIN MOUNTING STUDS

4X 3/8" NUT (SUPPLIED)

**DRINKING FOUNTAIN HARDWARE**  
(2 PLACES)  
1001/1101 INSTALLATION SHOWN, OTHER DRINKING FOUNTAIN MODELS FOLLOW THE SAME INSTALLATION STEPS AND CONTAIN SIMILAR PARTS.

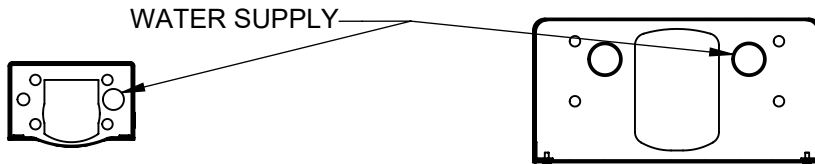

**1001/1101 HOLE PATTERN**

**1107/1117 & 1109/1119 HOLE PATTERN**

 <b>Haws</b> Since 1906		1455 KLEPPE LANE SPARKS, NEVADA 89431 (775) 359-4712 FAX (775) 359-7424 E-MAIL: HAWS@HAWS.CO.COM WEBSITE: WWW.HAWS.CO.COM	
		ECN: 6000 DRAWN: DHP APPROVED: JU	REV. ECN: 6000 DATE: 12/15/22 DATE: 07/08/24
PART NUMBER 0510002202.D			REVISION 1
SCALE: 1:20   DRAWING TYPE: INSTALLATION		SIZE: A   SHEET 8 OF 11	



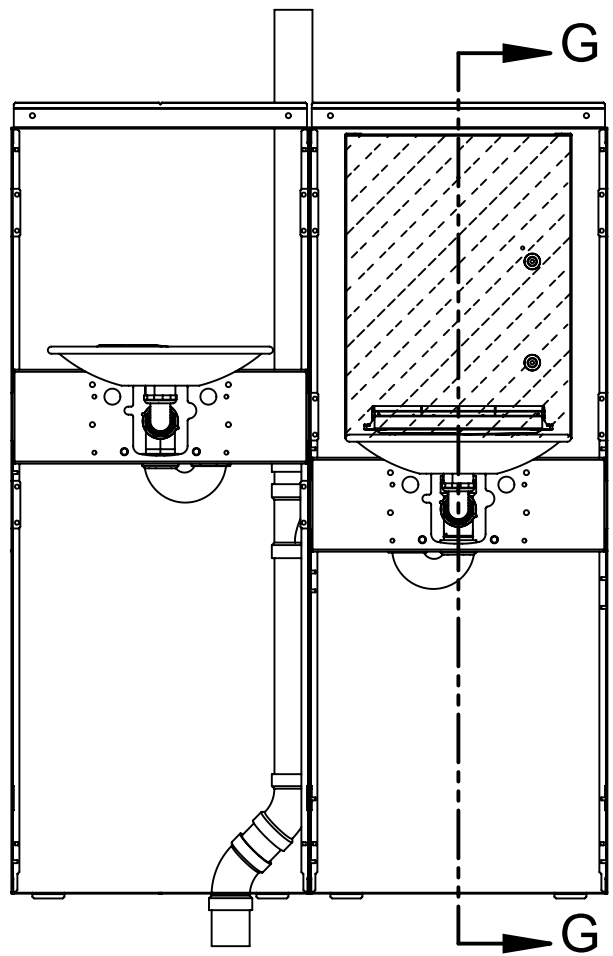

**FRONT VIEW**  
(SOME COMPONENTS HIDDEN FOR CLARITY)

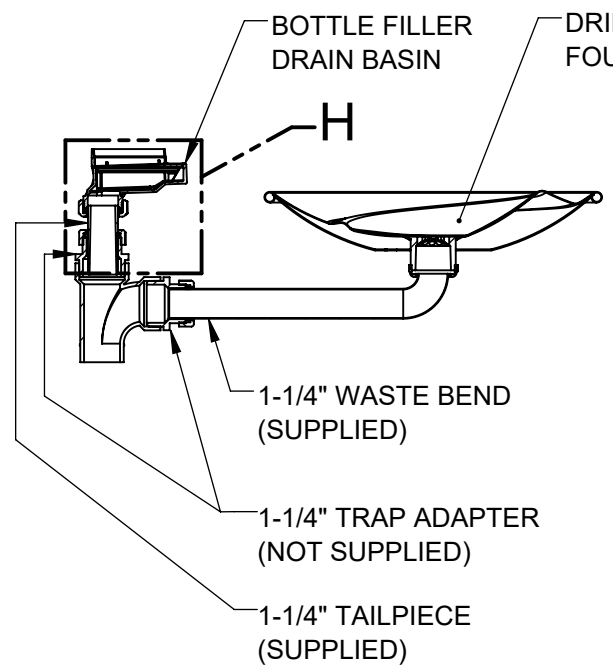

**SECTION G-G**  
(ENLARGED)

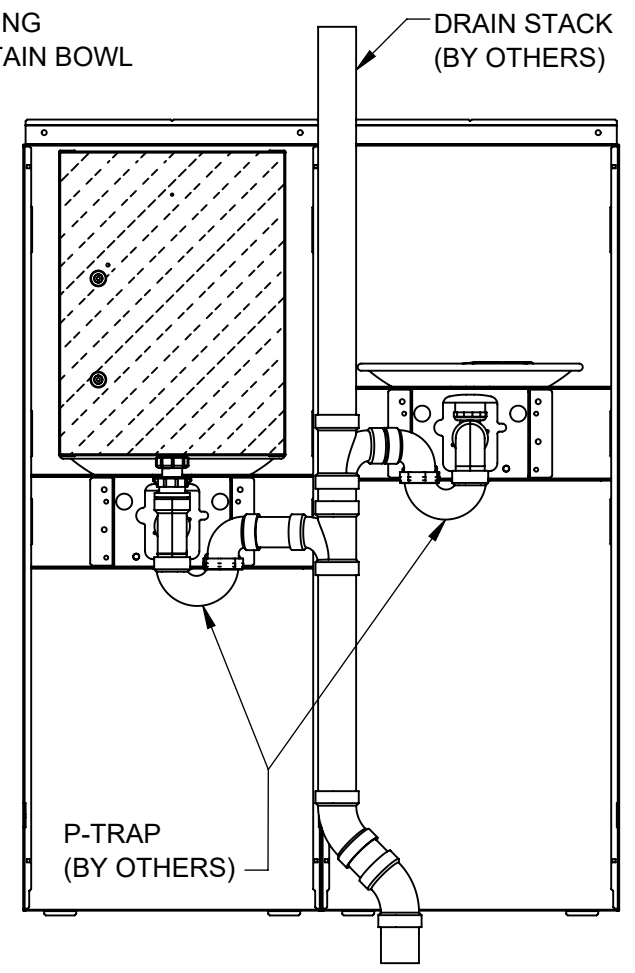

**BACK VIEW**  
(SOME COMPONENTS HIDDEN FOR CLARITY)

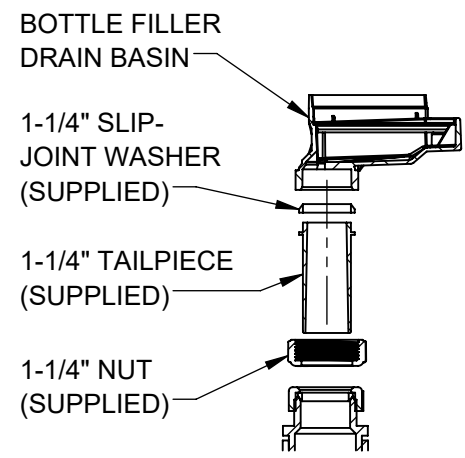

**DETAIL H**  
(EXPLODED VIEW)

**FOR REFERENCE ONLY**

DRAIN STACK SHOWN AS REFERENCE ONLY. LOCAL, STATE, OR FEDERAL CODES SHOULD BE ADHERED TO FOR PROPER DRAIN INSTALLATION.

		1455 KLEPPE LANE SPARKS, NEVADA 89431 (775) 359-4712 FAX (775) 359-7424 E-MAIL: HAWS@HAWS.CO.COM WEBSITE: WWW.HAWS.CO.COM	
		ECN: 6000 DRAWN: DHP APPROVED: JU	REV. ECN: 6000 DATE: 12/15/22 DATE: 07/08/24
PART NUMBER 0510002202.D			REVISION 1
SCALE: 1:12   DRAWING TYPE: INSTALLATION		SIZE: A   SHEET 9 OF 11	

15. INSTALL 3/8" TUBING AS SHOWN. NOTE DIRECTION OF FLOW ARROWS ON FILTER AND PRESSURE REDUCING VALVE. CUT ALL TUBING AND INSULATION AS REQUIRED, ENSURE TUBING IS CUT SQUARE AND FULLY INSERTED INTO PUSH-TO-CONNECT FITTINGS.

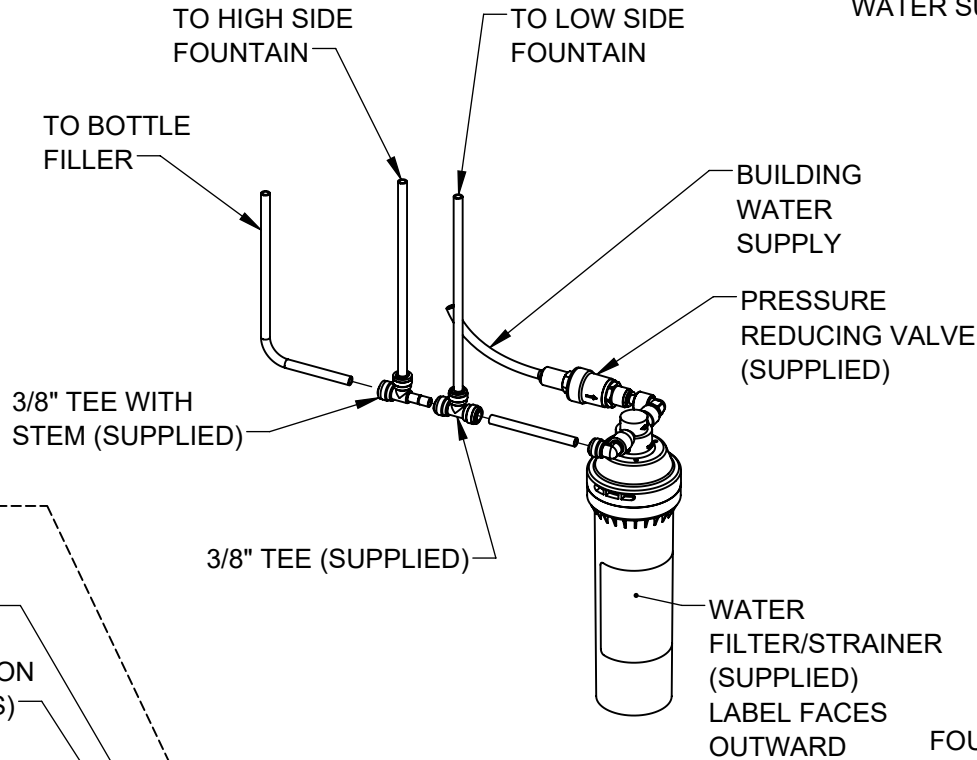

**WATERWAY DIAGRAM**

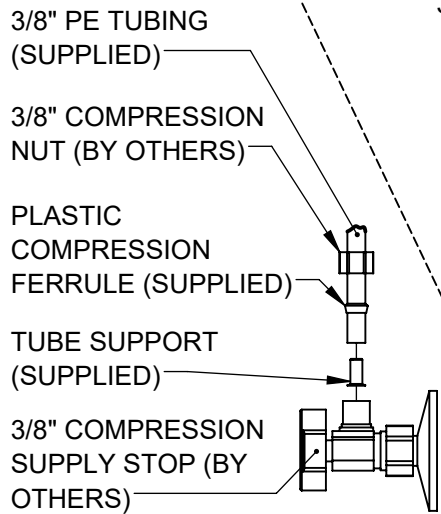

**WATER SUPPLY CONNECTION**

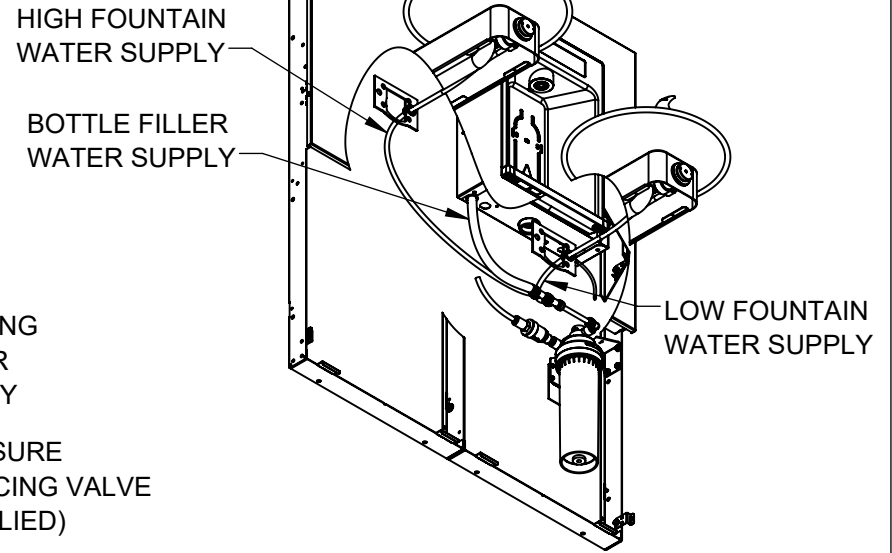

**WATERWAY LAYOUT**  
(SOME COMPONENTS HIDDEN FOR CLARITY)

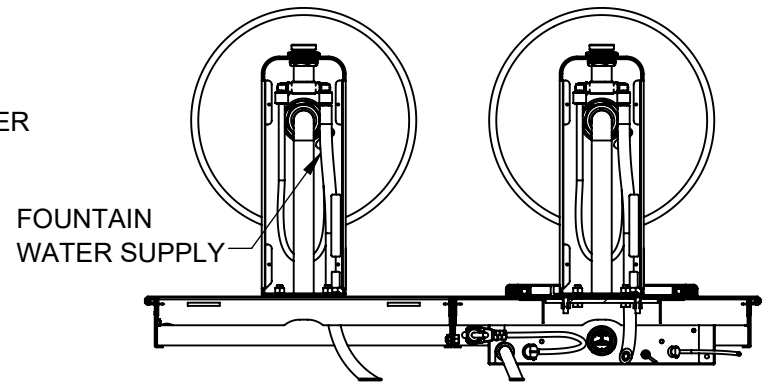

**BOTTOM VIEW**  
(SOME COMPONENTS HIDDEN FOR CLARITY)

**Haws**<sup>®</sup>  
Since 1906

1455 KLEPPE LANE  
SPARKS, NEVADA 89431  
(775) 359-4712 FAX (775) 359-7424  
E-MAIL: HAWS@HAWSO.COM  
WEBSITE: WWW.HAWSO.COM

ECN: 6000	REV. ECN: 6000	BY: DHP	MODEL(S)	PART NUMBER
DRAWN: DHP	DATE: 12/15/22	CHKD: DHP	1XXXHSA, DUAL FOUNTAIN MODELS	0510002202.D
APPROVED: JU	DATE: 07/08/24	SCALE: 1:16	DRAWING TYPE: INSTALLATION	REVISION
			SIZE: A	1
			SHEET 10 OF 11	

16. CONNECT THE NEMA 5-15P BOTTLE FILLER PLUG TO THE NEMA 5-15R RECEPTACLE. VERIFY THAT THE BOTTLE FILLER DISPLAY HAS POWERED ON.
17. INSTALL THE FILTER CARTRIDGE INTO THE FILTER HEAD.
18. MOUNT THE LOWER PANEL USING 2X #8 PANEL SCREWS (SUPPLIED).
19. INSTALL DRINKING FOUNTAIN LOWER COVERS WITH 4X #8 PAN HEAD SCREWS (SUPPLIED) PER FOUNTAIN.

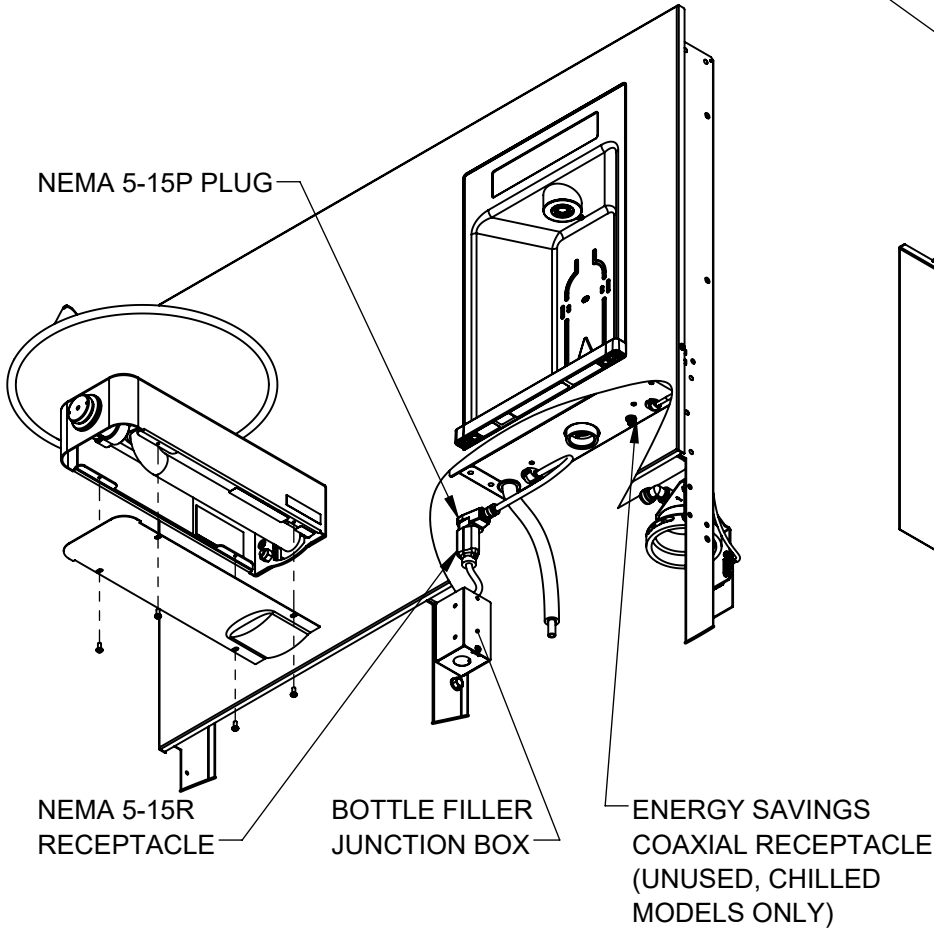

**ELECTRICAL CONNECTIONS AND DRINKING FOUNTAIN LOWER COVER (SOME COMPONENTS HIDDEN FOR CLARITY)**

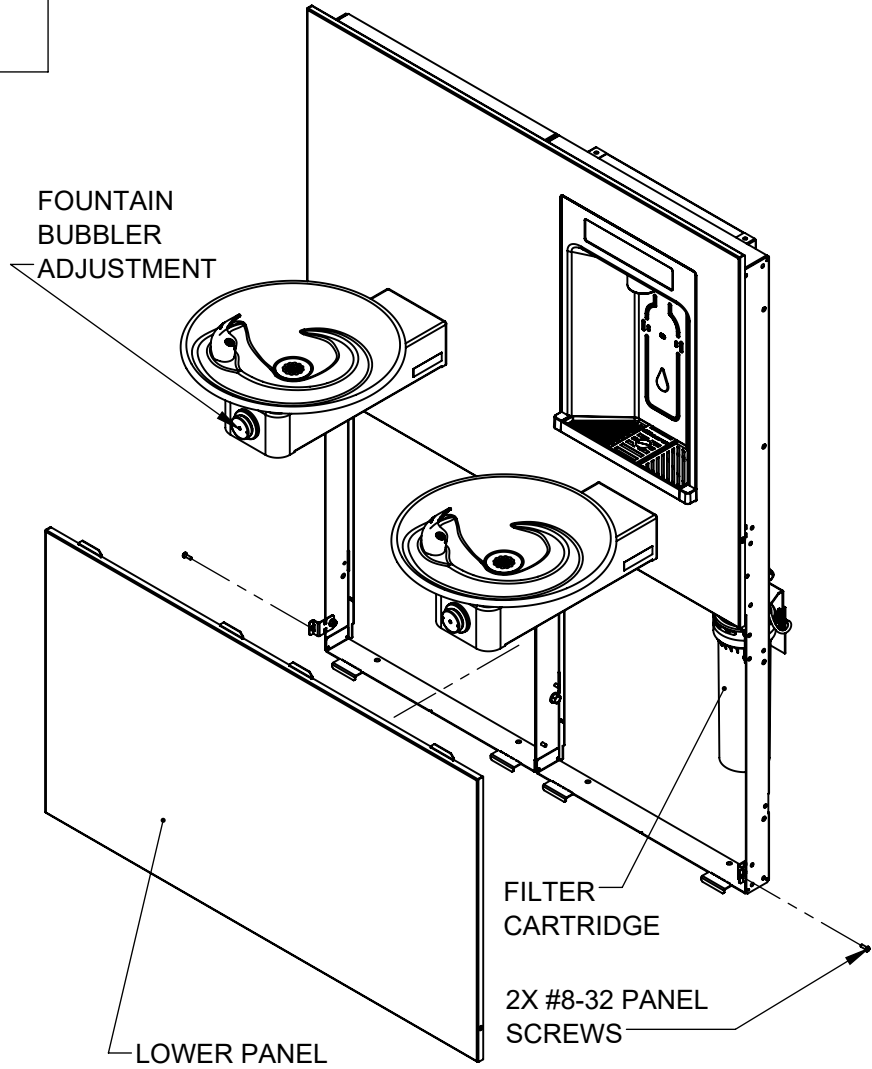

**LOWER PANEL INSTALLATION**

 <b>Haws</b> Since 1906		1455 KLEPPE LANE SPARKS, NEVADA 89431 (775) 359-4712 FAX (775) 359-7424 E-MAIL: HAWS@HAWS.CO.COM WEBSITE: WWW.HAWS.CO.COM	
		ECN: 6000 DRAWN: DHP APPROVED: JU	REV. ECN: 6000 DATE: 12/15/22 DATE: 07/08/24
PART NUMBER 0510002202.D			REVISION 1
SCALE: 1:12   DRAWING TYPE: INSTALLATION		SIZE: A   SHEET 11 OF 11	