

NOTES:

- ACCESS TO THE BACK SIDE OF THE WALL IS REQUIRED TO INSTALL AND MAINTAIN 1XXXHS MODELS. THESE MODELS ARE SUITABLE FOR WALLS WITH DRYWALL (5/8" MAX) SHEATHING ONLY.
- HOLD ROUGH-IN DIMENSIONS  $\pm 1/4"$  (6.4mm).
- WHEN INSTALLING THIS UNIT, LOCAL, STATE, OR FEDERAL CODES SHOULD BE ADHERED TO. INSTALL A TRAP IN THE WASTE LINE AND A SCREWDRIVER STOP IN THE SUPPLY LINE IF REQUIRED.

	A	B	C	D	
<b>FOUNTAIN MODELS</b>	<b>LOW SIDE BUBBLER</b>	<b>HIGH SIDE BUBBLER</b>	<b>LOW SIDE DRAIN</b>	<b>HIGH SIDE DRAIN</b>	<b>WASTE BEND SIZE</b>
1001/1011	33 13/16" [858mm]	39 5/16" [998mm]	28" [711mm]	33 1/2" [851mm]	1-1/4"
1107/1117	32 13/16" [834mm]	38 5/16" [974mm]	27 5/16" [694mm]	32 13/16" [834mm]	1-1/4"
1109/1119	34 7/16" [875mm]	39 15/16" [1014mm]	28 1/4" [718mm]	33 3/4" [857mm]	1-1/4"

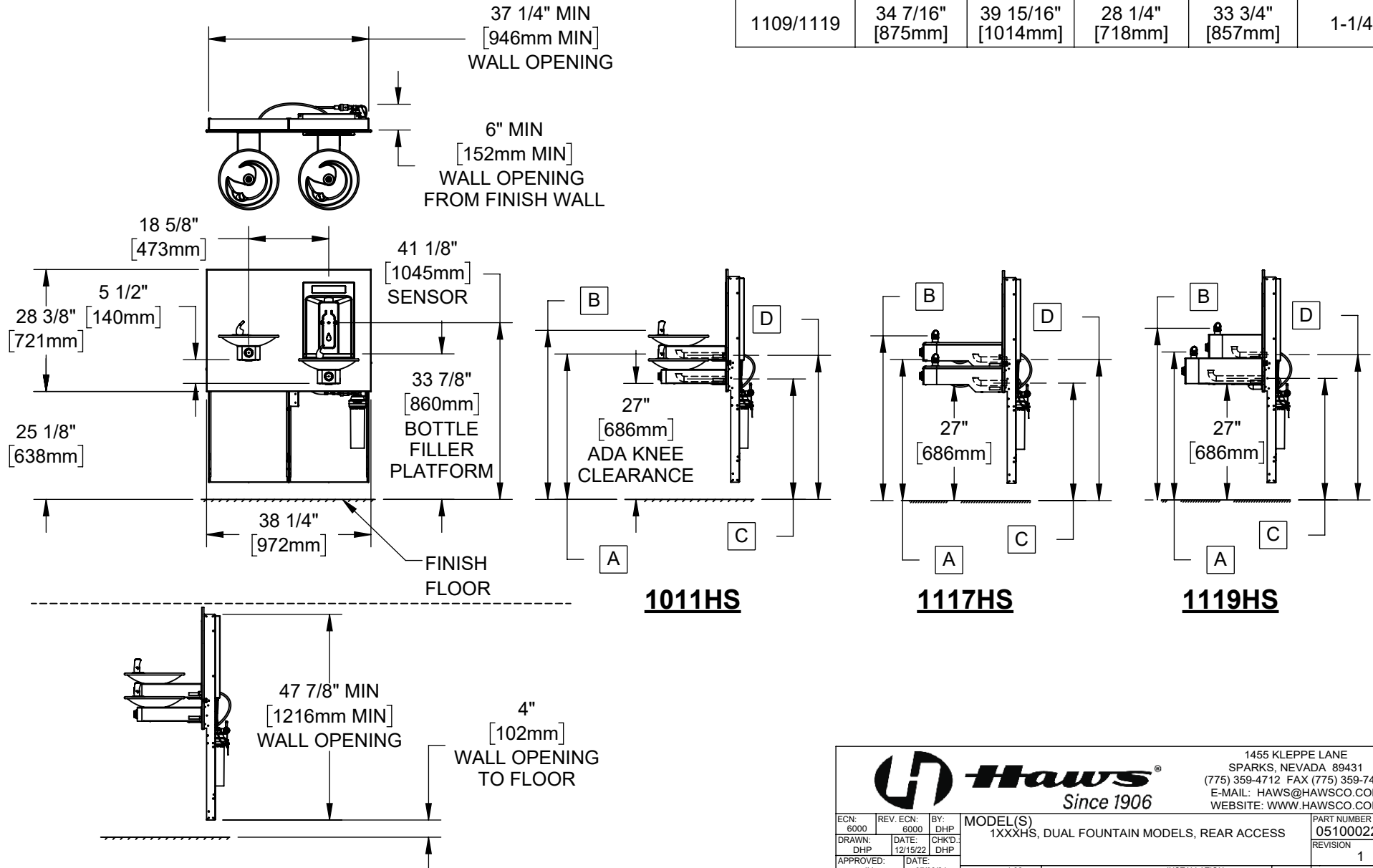

1455 KLEPPE LANE  
SPARKS, NEVADA 89431  
(775) 359-4712 FAX (775) 359-7424  
E-MAIL: HAWS@HAWS.CO.COM  
WEBSITE: WWW.HAWS.CO.COM

ECN: 6000	REV. ECN: 6000	BY: DHP	MODEL(S) 1XXXHS, DUAL FOUNTAIN MODELS, REAR ACCESS	PART NUMBER 0510002203.D
DRAWN: DHP	DATE: 12/15/22	CHKD: DHP		REVISION 1
APPROVED: JU	DATE: 07/08/24	SCALE: 1:32	DRAWING TYPE: INSTALLATION	SIZE: A SHEET 1 OF 11

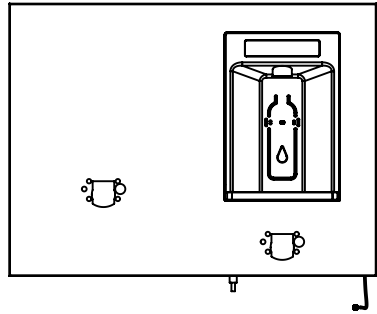

BOTTLE FILLER  
(HS4 SHOWN FOR REFERENCE)

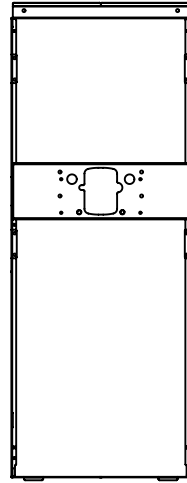

HIGH SIDE FRAME  
(0410000901)

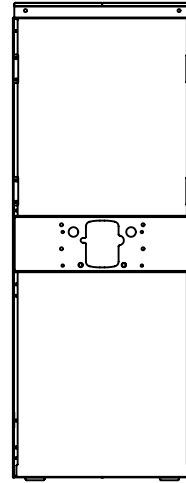

LOW SIDE FRAME (HS11)

HS12



1011 FOUNTAIN (2X, HS7)

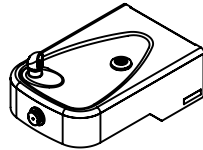

1117 FOUNTAIN (2X, HS8)

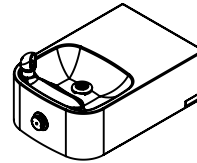

1119 LOW SIDE FOUNTAIN (HS9)

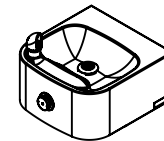

1119 HIGH SIDE FOUNTAIN (HS10)

HS MODEL #	BOTTLE FILLER	LOW SIDE FRAME	HIGH SIDE FRAME	LOW SIDE FOUNTAIN	HIGH SIDE FOUNTAIN	LOOSE PARTS KIT
1011HS	HS4	HS11	0410000901	HS7	HS7	HS106
1117HS	HS6	HS11	0410000901	HS8	HS8	HS106
1119HS	HS6	HS11	0410000901	HS9	HS10	HS106



1455 KLEPPE LANE  
SPARKS, NEVADA 89431  
(775) 359-4712 FAX (775) 359-7424  
E-MAIL: HAWS@HAWS.CO.COM  
WEBSITE: WWW.HAWS.CO.COM

ECN: 6000	REV. ECN: 6000	BY: DHP	MODEL(S) 1XXXHS, DUAL FOUNTAIN MODELS, REAR ACCESS	PART NUMBER 0510002203.D
DRAWN: DHP	DATE: 12/15/22	CHKD: DHP		REVISION 1
APPROVED: JU	DATE: 07/08/24	SCALE: 1:20	DRAWING TYPE: INSTALLATION	SIZE: A SHEET 2 OF 11

4. ROUGH IN WALL CAVITY WITH DIMENSIONS SHOWN. ROUGH IN ELECTRICAL, WASTE PIPING, AND WATER SUPPLY AS REQUIRED

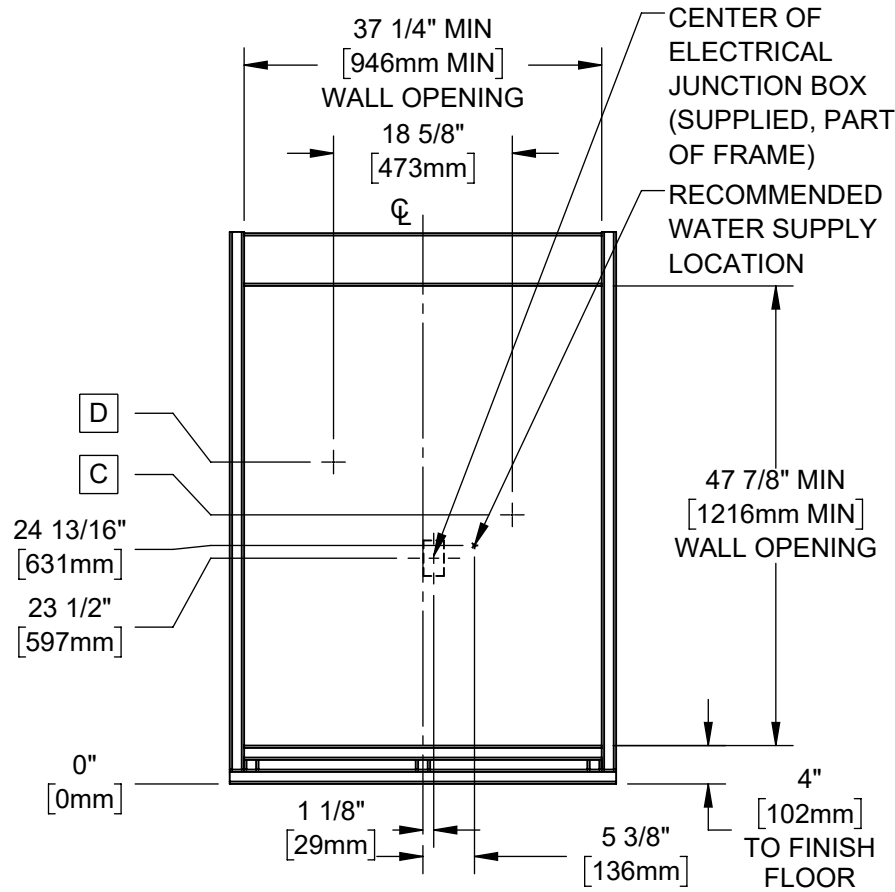

TYPICAL WALL OPENING

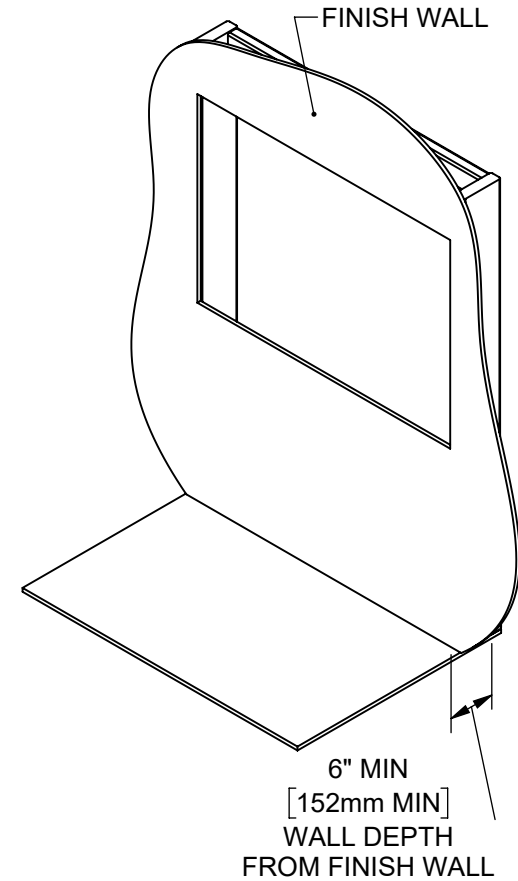

	C	D	
FOUNTAIN MODELS	LOW SIDE DRAIN	HIGH SIDE DRAIN	WASTE BEND SIZE
1001/1011	28" [711mm]	33 1/2" [851mm]	1-1/4"
1107/1117	27 5/16" [694mm]	32 13/16" [834mm]	1-1/4"
1109/1119	28 1/2" [718mm]	33 3/4" [857mm]	1-1/4"



**Haws**<sup>®</sup>

Since 1906

1455 KLEPPE LANE  
SPARKS, NEVADA 89431  
(775) 359-4712 FAX (775) 359-7424  
E-MAIL: HAWS@HAWS.CO.COM  
WEBSITE: WWW.HAWS.CO.COM

ECN: 6000	REV. ECN: 6000	BY: DHP	MODEL(S): 1XXXHS, DUAL FOUNTAIN MODELS, REAR ACCESS	PART NUMBER: 0510002203.D
DRAWN: DHP	DATE: 12/15/22	CHKD: DHP		REVISION: 1
APPROVED: JU	DATE: 07/08/24	SCALE: 1:20	DRAWING TYPE: INSTALLATION	SIZE: A SHEET 3 OF 11

5. BOLT FRAMES TOGETHER USING 4X 5/16" BOLTS AND NUTS AS SHOWN (DETAIL A). REMOVE 4X DRYWALL TABS FROM THE BOTTOM OF THE FRAMES BY BENDING ALONG PERFORATIONS (DETAIL B).
6. MOUNT FRAME ASSEMBLY INTO WALL CAVITY FROM THE BACK SIDE OF THE FINISH WALL USING 16X STRUCTURAL SCREWS (NOT SUPPLIED), USE SHIMS AS NEEDED AND ENSURE THE FRAME IS SQUARE. INSTALL BLOCKING AND SUPPORT FOR DRYWALL AS NEEDED.
7. INSTALL THE 2X PANEL CLIPS USING #10 NUTS (SUPPLIED) AS SHOWN (DETAIL C).

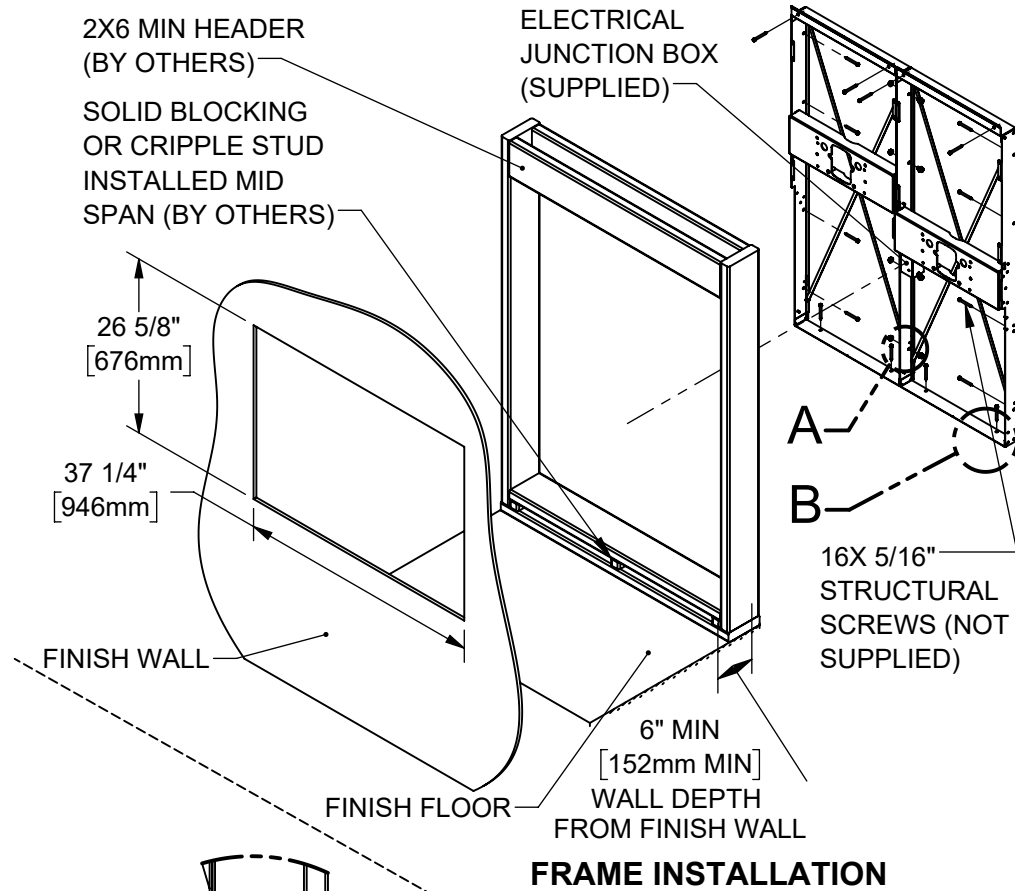

**FRAME INSTALLATION**

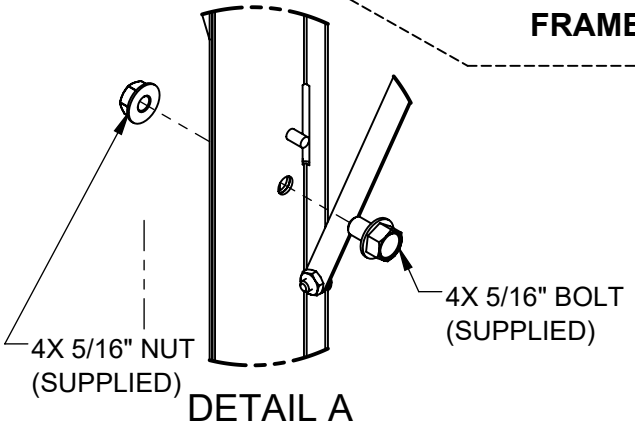

**DETAIL A**

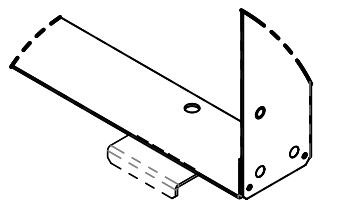

**DETAIL B  
DRYWALL TAB REMOVAL  
(4 PLACES)**

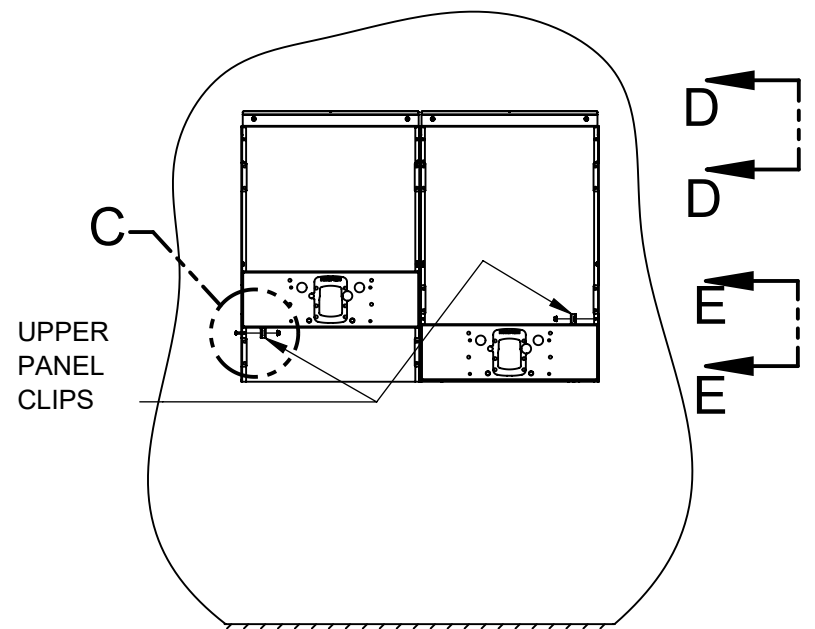

**UPPER  
PANEL  
CLIPS**

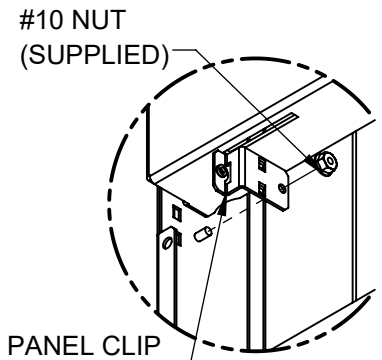

**DETAIL C  
PANEL CLIP  
INSTALL  
(2 PLACES)**

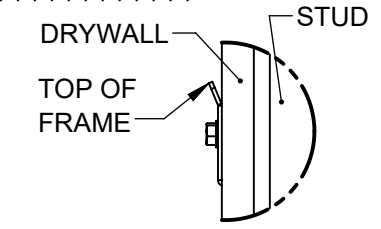

**VIEW ON D-D  
(ENLARGED)**

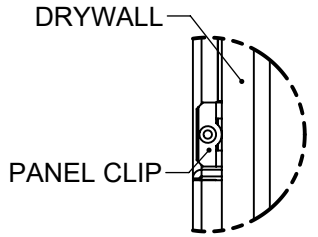

**VIEW ON E-E  
(ENLARGED)**

		1455 KLEPPE LANE SPARKS, NEVADA 89431 (775) 359-4712 FAX (775) 359-7424 E-MAIL: HAWS@HAWSCO.COM WEBSITE: WWW.HAWSCO.COM	
		ECN: 6000 DRAWN: DHP APPROVED: JU	REV. ECN: 6000 DATE: 12/15/22 DATE: 07/08/24
SCALE: 1:20   DRAWING TYPE: INSTALLATION   SIZE: A			PART NUMBER: 0510002203.D REVISION: 1 SHEET 4 OF 11

8. REMOVE SHIPPING BRACKETS FROM RIGHT AND LEFT FRAME (DETAIL F).
9. INSTALL FILTER HEAD USING 3X SUPPLIED #10 NUTS (DETAIL G).
10. (1011HS ONLY) INSTALL 1001 DRINKING FOUNTAIN ADAPTERS USING 2X SUPPLIED 3/8" NUTS (DETAIL H).

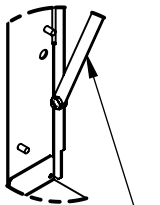
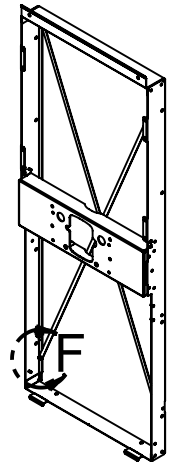

REMOVE SHIPPING CROSS BRACING

**DETAIL F**  
(4 PLACES)

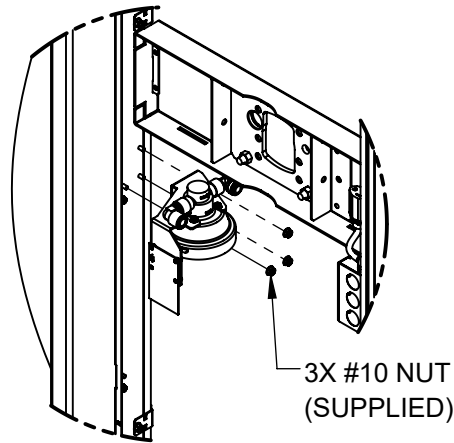

3X #10 NUT  
(SUPPLIED)

**DETAIL G**  
FILTER/STRAINER HEAD INSTALL  
(ALL MODELS)

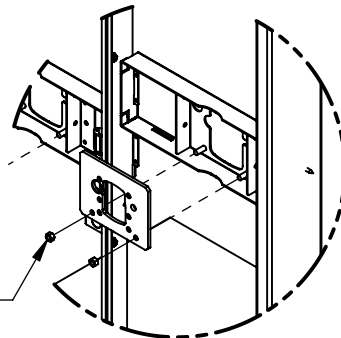

2X 3/8" NUT  
(SUPPLIED)

**DETAIL H**  
1001 FOUNTAIN ADAPTER PLATE (1001/1011  
MODELS ONLY)

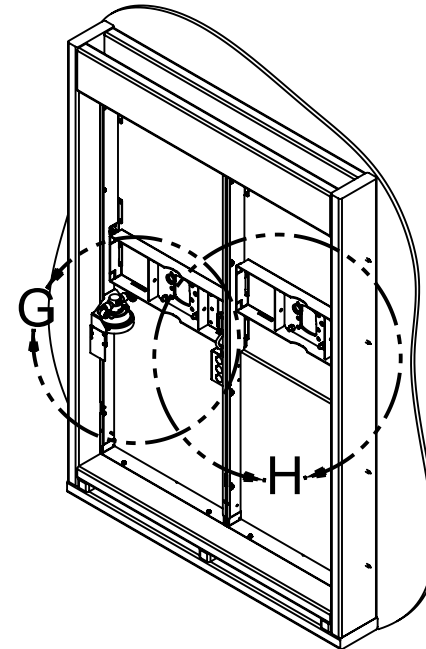

**REAR VIEW**



**Haws**  
Since 1906

1455 KLEPPE LANE  
SPARKS, NEVADA 89431  
(775) 359-4712 FAX (775) 359-7424  
E-MAIL: HAWS@HAWSO.COM  
WEBSITE: WWW.HAWSO.COM

ECN: 6000	REV. ECN: 6000	BY: DHP	MODEL(S) 1XXXHS, DUAL FOUNTAIN MODELS, REAR ACCESS	PART NUMBER 0510002203.D
DRAWN: DHP	DATE: 12/15/22	CHKD: DHP		REVISION 1
APPROVED: JU	DATE: 07/08/24	SCALE: 1:20	DRAWING TYPE: INSTALLATION	SIZE: A
				SHEET 5 OF 11

11. INSTALL 8X 3/8" DRINKING FOUNTAIN BOLTS (SUPPLIED) FROM THE BACK SIDE OF THE FRAME.
12. HANG THE BOTTLE FILLER FROM THE TOP OF THE FRAME AND ALIGN THE PANEL SO THE 3/8" DRINKING FOUNTAIN BOLTS PROTRUDE THROUGH THE PANEL. INSTALL THE 2X #8 PANEL SCREWS (SUPPLIED) ON EITHER SIDE OF THE BOTTLE FILLER PANEL.
13. CONNECT THE FILTER CABLE (RIGHT SIDE OF THE BOTTLE FILLER) TO THE FILTER TRACKING BOARD.

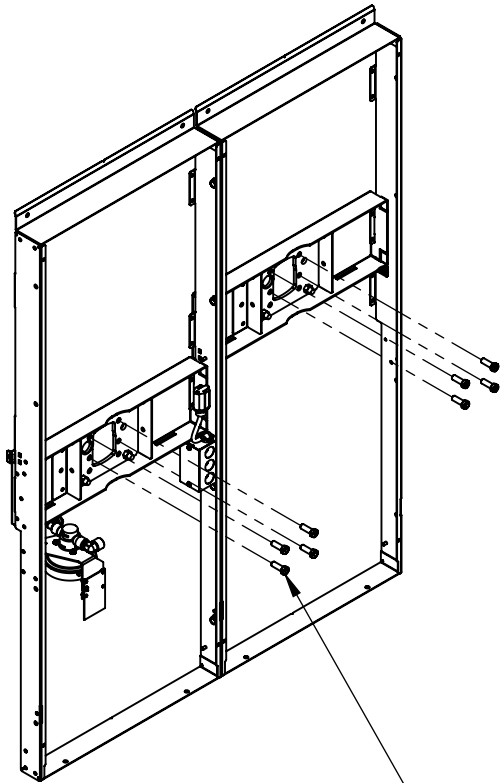

8X DRINKING FOUNTAIN BOLTS (SUPPLIED). USE WASHERS (SUPPLIED) UNDER HEAD OF BOLTS FOR 1107/1117 AND 1109/1119 MODELS

**REAR VIEW**

2X #8-32 BUTTON HEAD PANEL SCREWS (SUPPLIED)

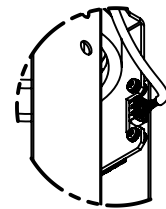
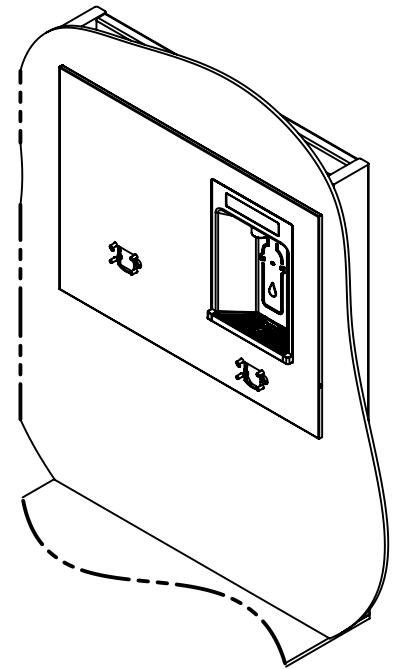
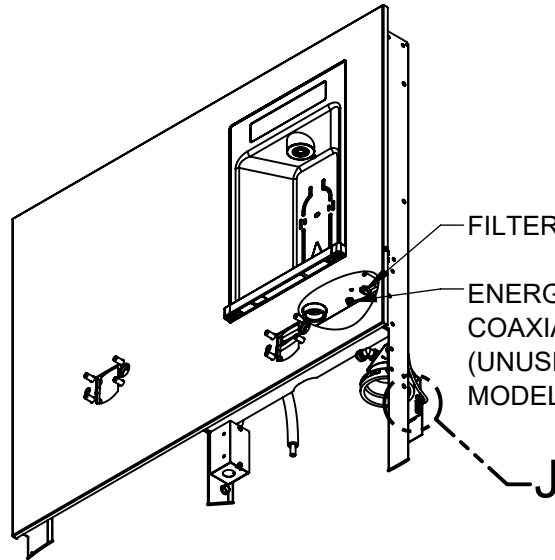
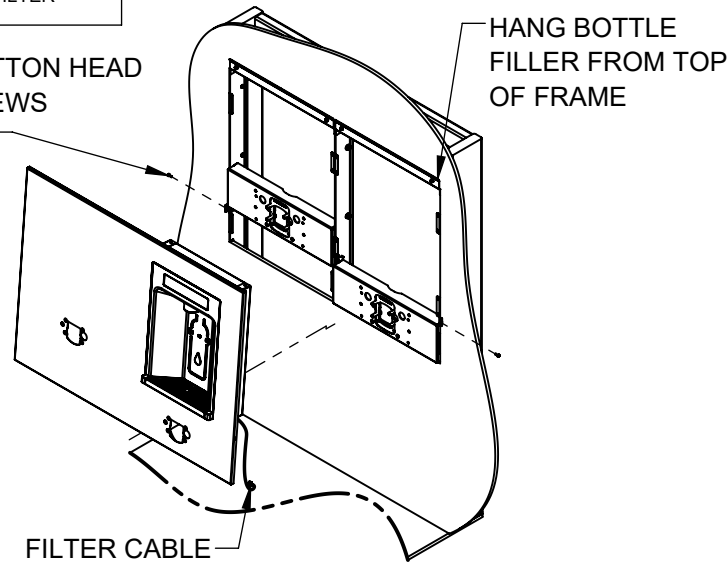

**DETAIL J**  
FILTER TRACKING ELECTRICAL CONNECTION

 <b>Haws</b> Since 1906		1455 KLEPPE LANE SPARKS, NEVADA 89431 (775) 359-4712 FAX (775) 359-7424 E-MAIL: HAWS@HAWS.CO.COM WEBSITE: WWW.HAWS.CO.COM	
		ECN: 6000 DRAWN: DHP APPROVED: JU	REV. ECN: 6000 DATE: 12/15/22 DATE: 07/08/24
			PART NUMBER 0510002203.D REVISION 1
SCALE: 1:14		DRAWING TYPE: INSTALLATION	
SIZE: A		SHEET 6 OF 11	

**NOTE:** STEP 14 CAN BE PERFORMED LATER IN INSTALLATION IF DESIRED.

14. HAVE AN ELECTRICIAN CONNECT A 120VAC/60HZ 15-AMP GFCI-PROTECTED CIRCUIT TO THE RESPECTIVE LINE, NEUTRAL, AND GROUND CONNECTIONS INSIDE THE BOTTLE FILLER JUNCTION BOX VIA ONE OF THE AVAILABLE 1/2" KNOCKOUTS.

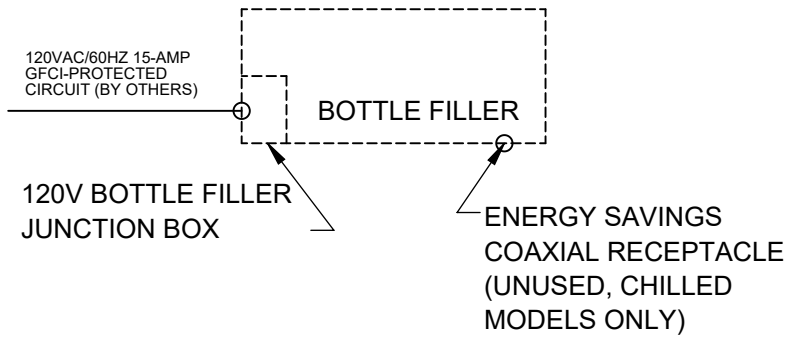

### ELECTRICAL WIRING OVERVIEW

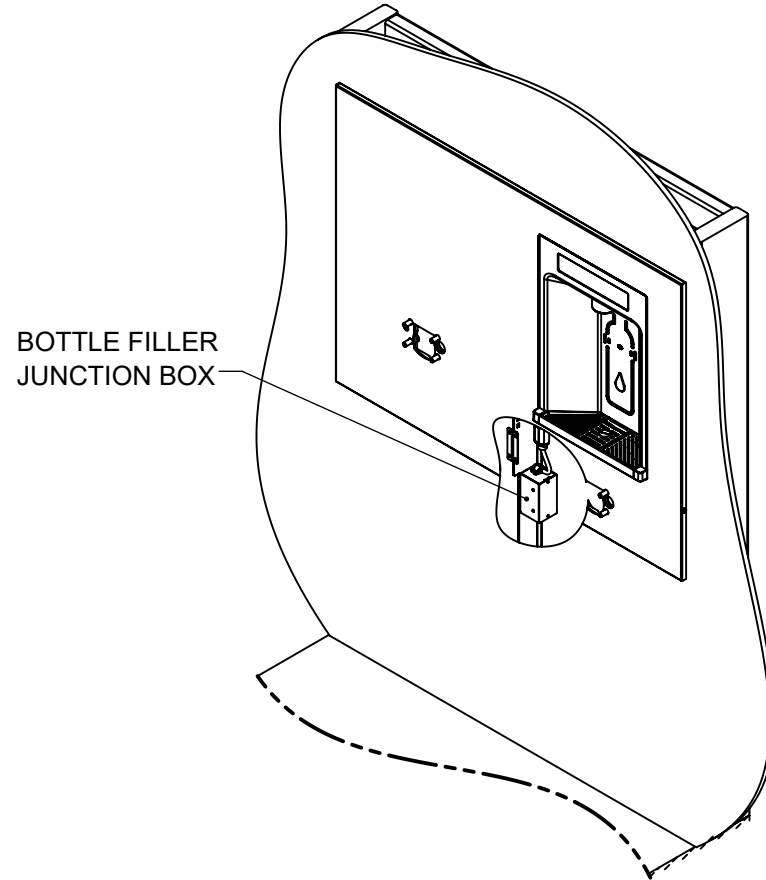

 <b>Haws</b> Since 1906			1455 KLEPPE LANE SPARKS, NEVADA 89431 (775) 359-4712 FAX (775) 359-7424 E-MAIL: HAWS@HAWSO.COM WEBSITE: WWW.HAWSO.COM	
			ECN: 6000 REV. ECN: 6000 BY: DHP DRAWN: DHP APPROVED: JU	DATE: 12/15/22 DATE: 07/08/24
SCALE: 1:20   DRAWING TYPE: INSTALLATION   SIZE: A			SHEET 7 OF 11	

15. MOUNT THE DRINKING FOUNTAIN TO THE PROTRUDING 3/8" STUDS FROM STEP 11. INSTALL 4X 3/8" NUTS (SUPPLIED) PER DRINKING FOUNTAIN AND TIGHTEN FULLY (25 LB-FT).
16. INSTALL THE WASTE BEND (SUPPLIED), CUT TO LENGTH AS REQUIRED. REFER TO SHEET 3 FOR DRAIN HEIGHTS FOR EACH MODEL. SET LOWER COVER AND #8 PAN HEAD SCREWS ASIDE, THESE WILL BE INSTALLED ONCE THE WATER SUPPLY PLUMBING IS COMPLETE.

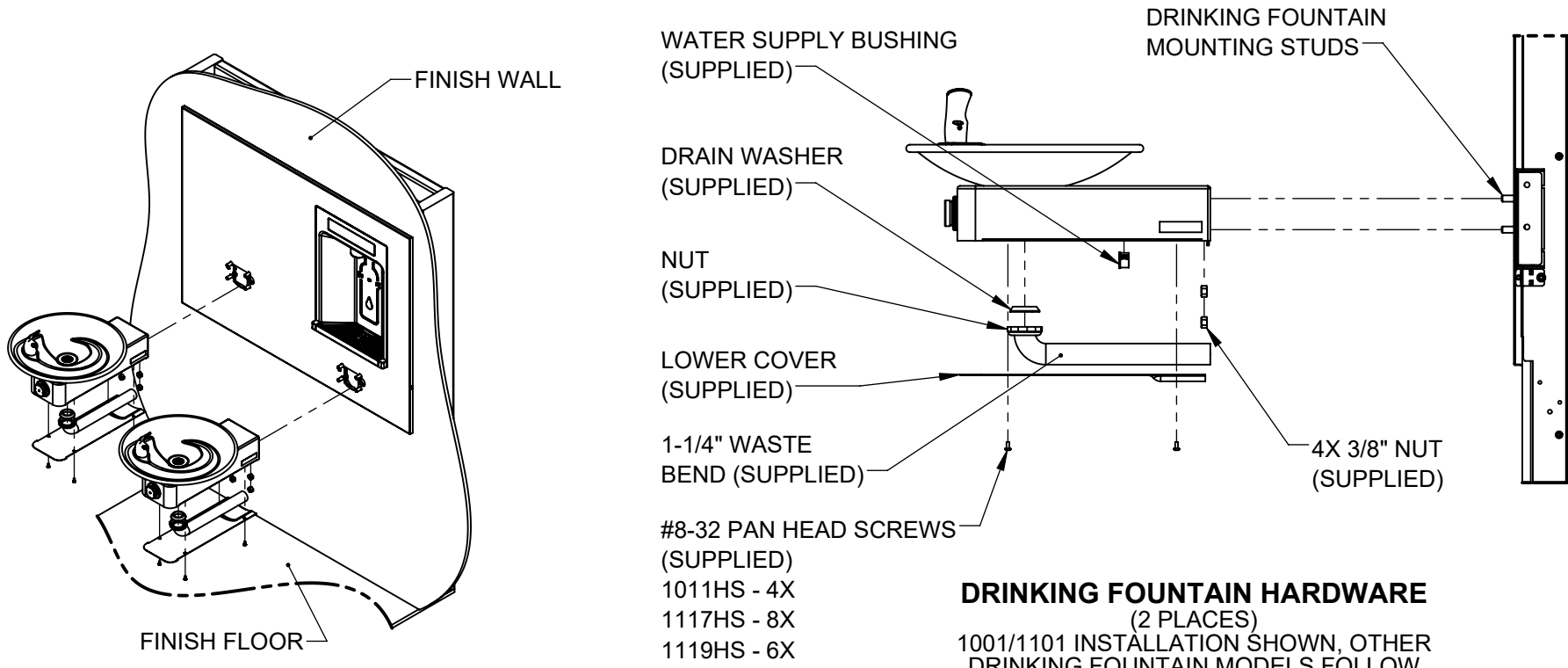

**DRINKING FOUNTAIN HARDWARE**  
 (2 PLACES)  
 1001/1101 INSTALLATION SHOWN, OTHER DRINKING FOUNTAIN MODELS FOLLOW THE SAME INSTALLATION STEPS AND CONTAIN SIMILAR PARTS.

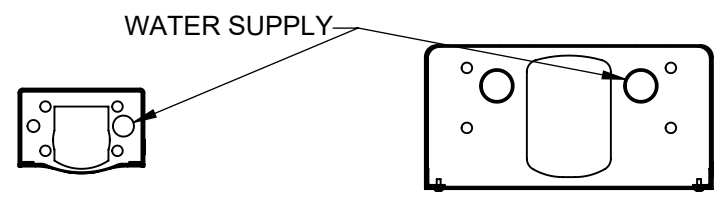

**1001/1101  
 HOLE  
 PATTERN**

**1107/1117 &  
 1109/1119 HOLE  
 PATTERN**

		1455 KLEPPE LANE SPARKS, NEVADA 89431 (775) 359-4712 FAX (775) 359-7424 E-MAIL: HAWS@HAWS.CO.COM WEBSITE: WWW.HAWS.CO.COM	
		ECN: 6000 DRAWN: DHP APPROVED: JU	REV. ECN: 6000 DATE: 12/15/22 DATE: 07/08/24
PART NUMBER 0510002203.D REVISION 1			SHEET 8 OF 11



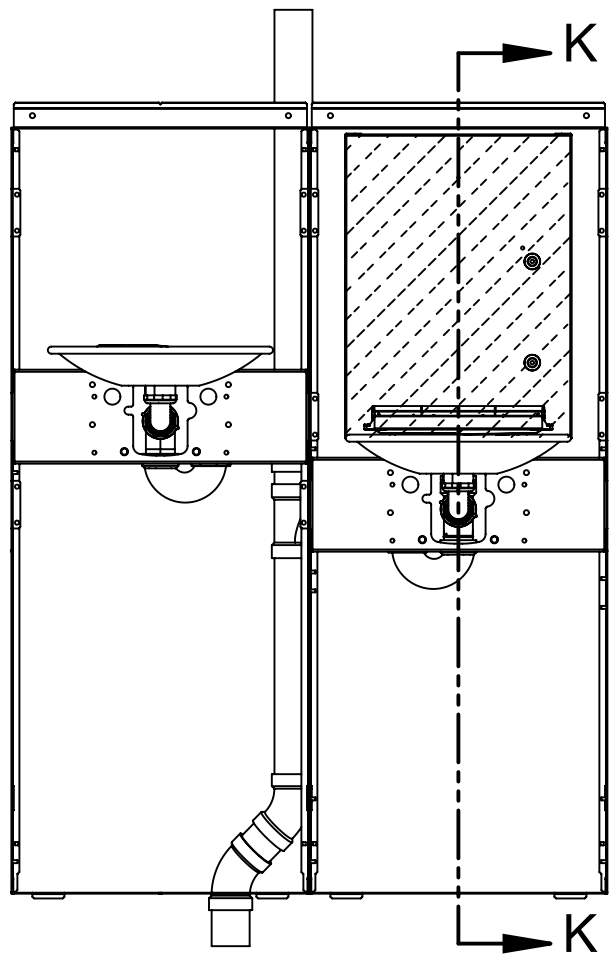

**FRONT VIEW**  
(SOME COMPONENTS HIDDEN FOR CLARITY)

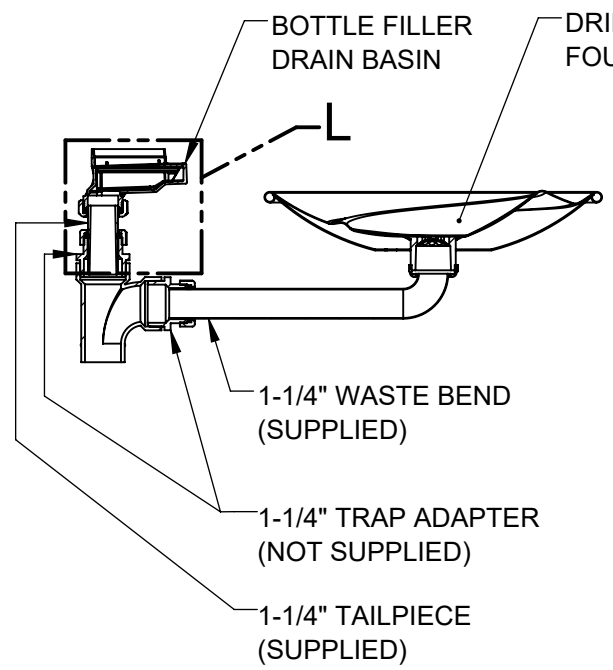

**SECTION K-K**  
(ENLARGED)

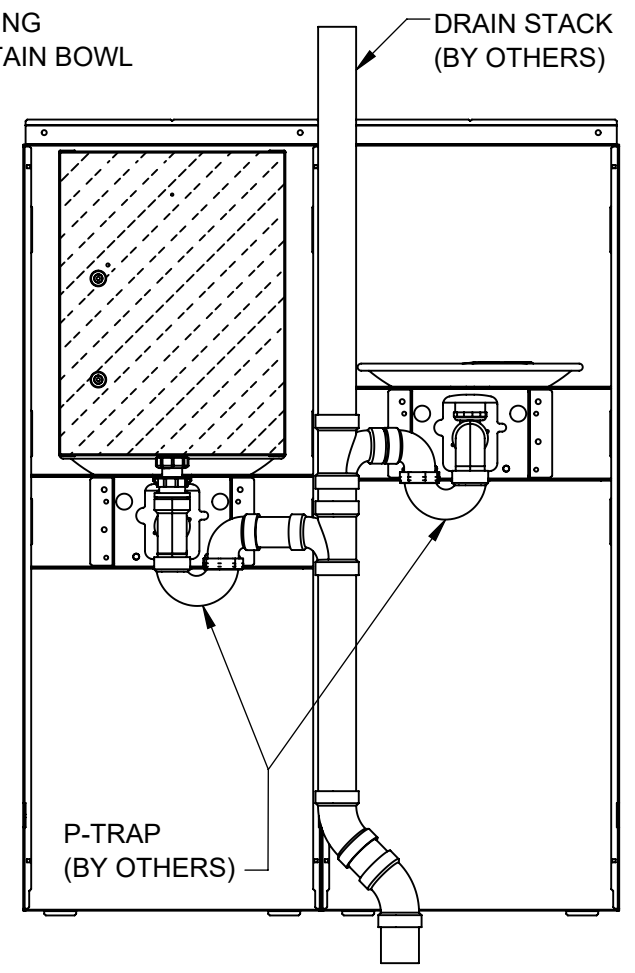

**BACK VIEW**  
(SOME COMPONENTS HIDDEN FOR CLARITY)

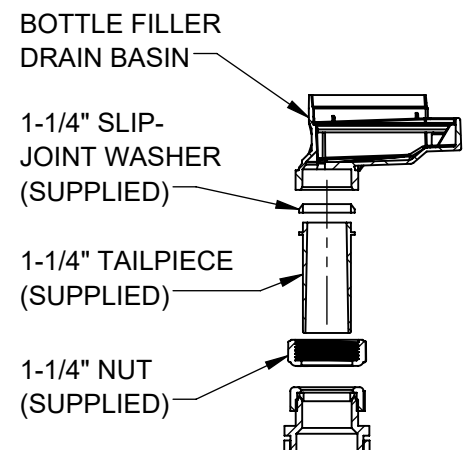

**DETAIL L**  
(EXPLODED VIEW)

**FOR REFERENCE ONLY**

DRAIN STACK SHOWN AS REFERENCE ONLY. LOCAL, STATE, OR FEDERAL CODES SHOULD BE ADHERED TO FOR PROPER DRAIN INSTALLATION.

		1455 KLEPPE LANE SPARKS, NEVADA 89431 (775) 359-4712 FAX (775) 359-7424 E-MAIL: HAWS@HAWS.CO.COM WEBSITE: WWW.HAWS.CO.COM	
		ECN: 6000 DRAWN: DHP APPROVED: JU	REV. ECN: 6000 DATE: 12/15/22 DATE: 07/08/24
SCALE: 1:12   DRAWING TYPE: INSTALLATION   SIZE: A			PART NUMBER 0510002203.D REVISION 1 SHEET 9 OF 11

17. INSTALL 3/8" TUBING AS SHOWN. NOTE DIRECTION OF FLOW ARROWS ON FILTER AND PRESSURE REDUCING VALVE. CUT ALL TUBING AND INSULATION AS REQUIRED, ENSURE TUBING IS CUT SQUARE AND FULLY INSERTED INTO PUSH-TO-CONNECT FITTINGS.

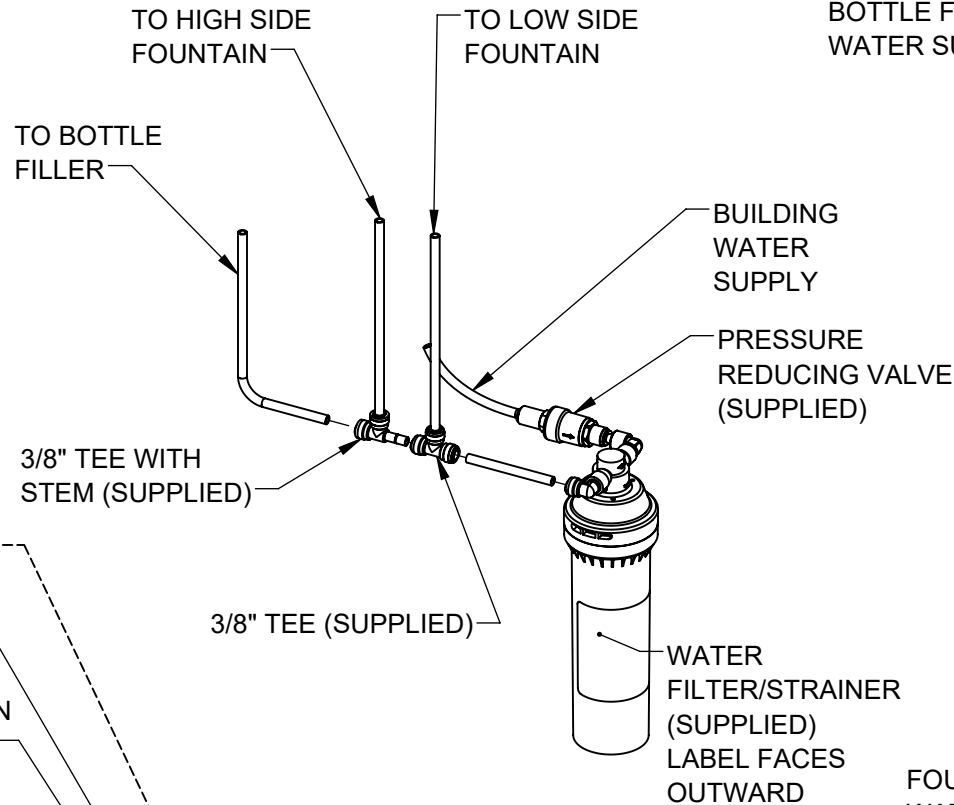

**WATERWAY DIAGRAM**

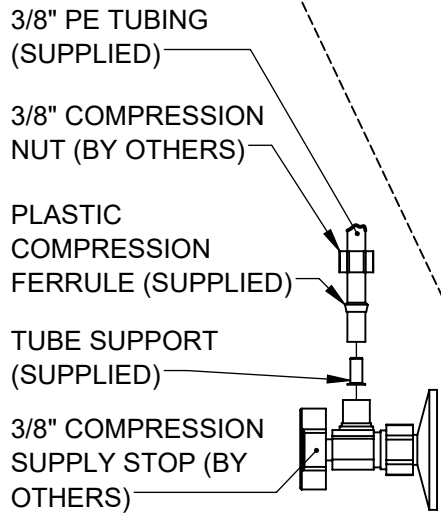

**WATER SUPPLY CONNECTION**

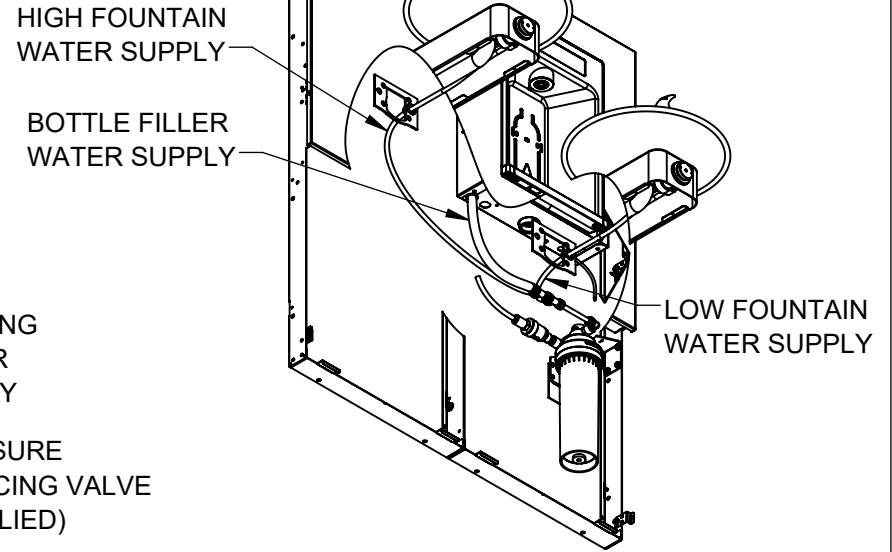

**WATERWAY LAYOUT**  
(SOME COMPONENTS HIDDEN FOR CLARITY)

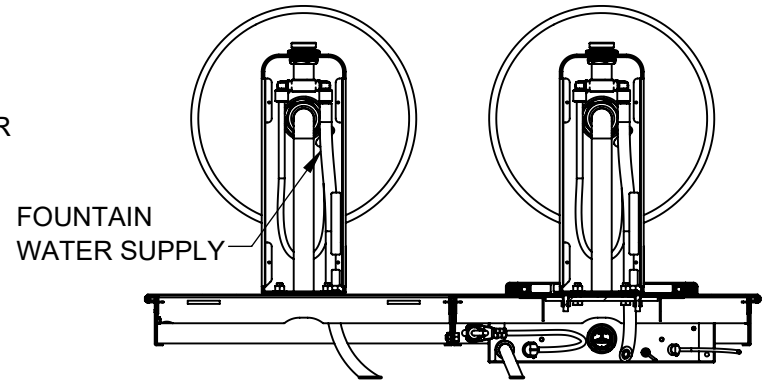

**BOTTOM VIEW**  
(SOME COMPONENTS HIDDEN FOR CLARITY)



**Haws**<sup>®</sup>

Since 1906

1455 KLEPPE LANE  
SPARKS, NEVADA 89431  
(775) 359-4712 FAX (775) 359-7424  
E-MAIL: HAWS@HAWS.CO.COM  
WEBSITE: WWW.HAWS.CO.COM

ECN: 6000	REV. ECN: 6000	BY: DHP	MODEL(S): 1XXXHS, DUAL FOUNTAIN MODELS, REAR ACCESS	PART NUMBER: 0510002203.D
DRAWN: DHP	DATE: 12/15/22	CHKD: DHP		REVISION: 1
APPROVED: JU	DATE: 07/08/24	SCALE: 1:16	DRAWING TYPE: INSTALLATION	SIZE: A SHEET 10 OF 11

18. CONNECT THE NEMA 5-15P BOTTLE FILLER PLUG TO THE NEMA 5-15R RECEPTACLE. VERIFY THAT THE BOTTLE FILLER DISPLAY HAS POWERED ON.
19. INSTALL THE FILTER CARTRIDGE INTO THE FILTER HEAD.
20. INSTALL DRINKING FOUNTAIN LOWER COVERS WITH 4X #8 PAN HEAD SCREWS (SUPPLIED) PER FOUNTAIN.

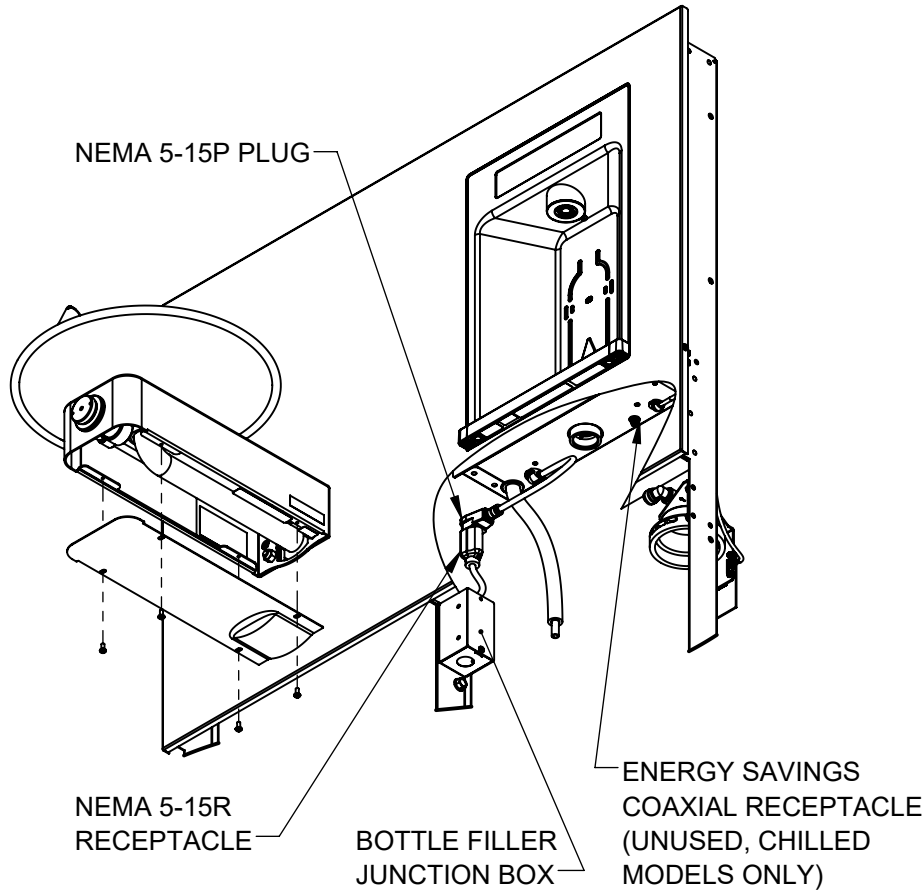

**ELECTRICAL CONNECTIONS AND DRINKING FOUNTAIN LOWER COVER**  
(SOME COMPONENTS HIDDEN FOR CLARITY)

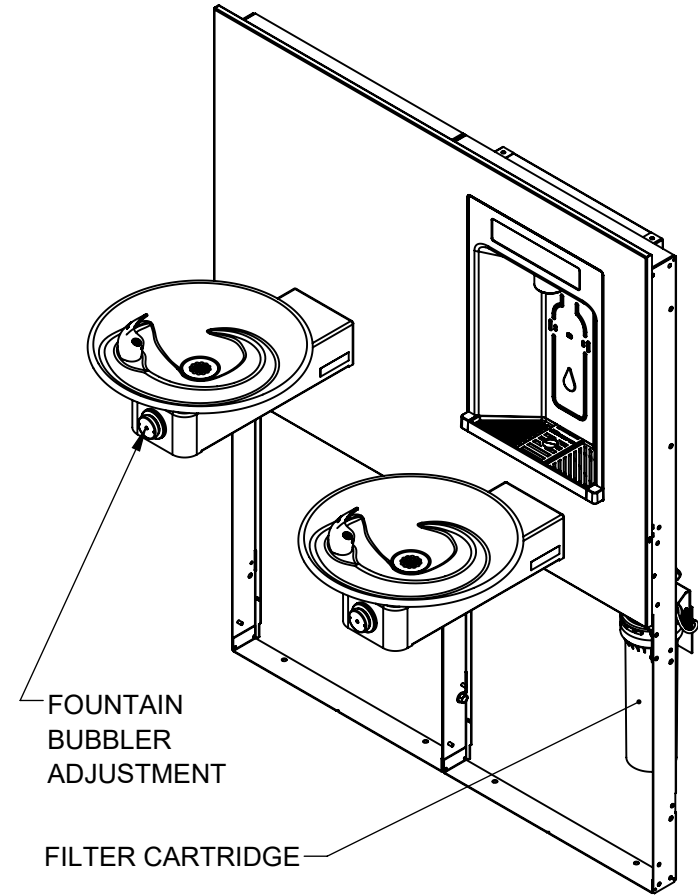

**FILTER INSTALL & BUBBLER ADJUSTMENT**

 <b>Haws</b> Since 1906		1455 KLEPPE LANE SPARKS, NEVADA 89431 (775) 359-4712 FAX (775) 359-7424 E-MAIL: HAWS@HAWSO.COM WEBSITE: WWW.HAWSO.COM	
		ECN: 6000 DRAWN: DHP APPROVED: JU	REV. ECN: 6000 DATE: 12/15/22 DATE: 07/08/24
			PART NUMBER 0510002203.D REVISION 1
SCALE: 1:12		DRAWING TYPE: INSTALLATION	
SIZE: A		SHEET 11 OF 11	