

NOTES:

1. HOLD ROUGH-IN DIMENSIONS $\pm 1/4"$ (6.4mm).
2. WHEN INSTALLING THIS UNIT, LOCAL, STATE, OR FEDERAL CODES SHOULD BE ADHERED TO. FOR CHILD-HEIGHT INSTALLATIONS ON 1107 MODELS, REDUCE DIMENSIONS MARKED (*) BY 3" [76mm]. INSTALL A TRAP IN THE WASTE LINE AND A SCREWDRIVER STOP IN THE SUPPLY LINE IF REQUIRED.

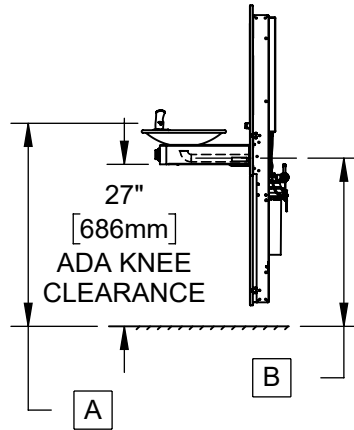

1001HSA

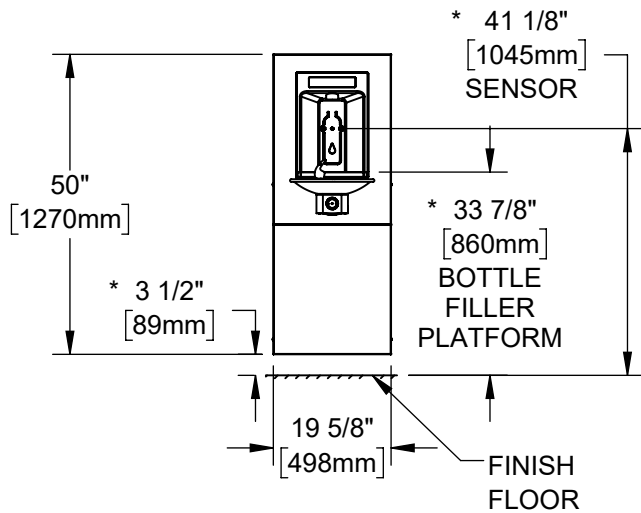
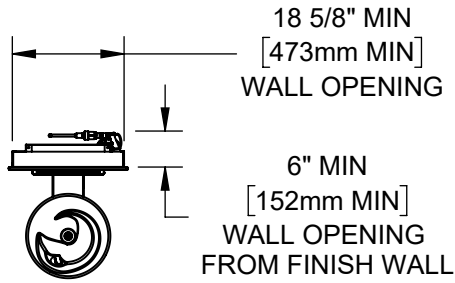
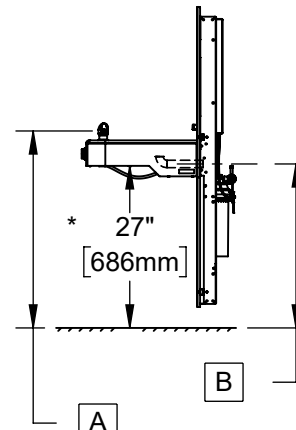

1107HSA

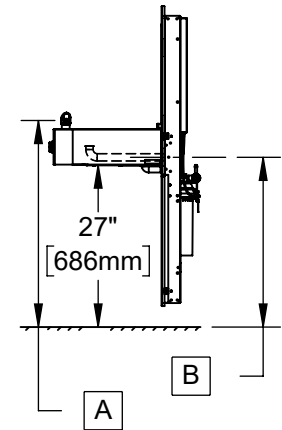

1109HSA

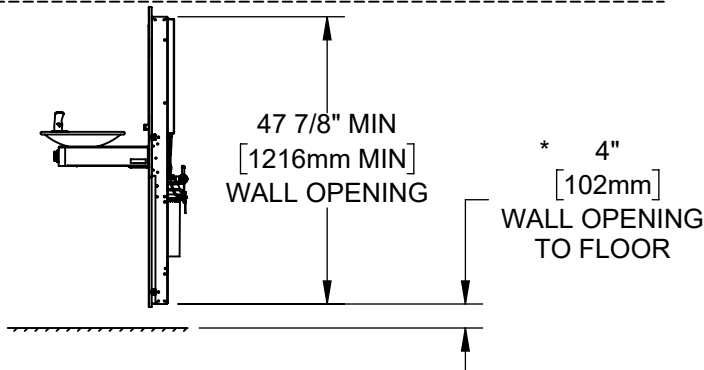

	A	B	
FOUNTAIN MODELS	BUBBLER HEIGHT	DRAIN HEIGHT	WASTE BEND SIZE
1001/1011	33 13/16" [858mm]	28" [711mm]	1-1/4"
1107/1117	*32 13/16" [834mm]	*27 5/16" [694mm]	1-1/4"
1109/1119	34 7/16" [875mm]	28 1/4" [718mm]	1-1/4"

1455 KLEPPE LANE
SPARKS, NEVADA 89431
(775) 359-4712 FAX (775) 359-7424
E-MAIL: HAWS@HAWS.CO.COM
WEBSITE: WWW.HAWS.CO.COM

ECN: 6000	REV. ECN: 6000	BY: DHP	MODEL(S)	PART NUMBER
DRAWN: DHP	DATE: 12/15/22	CHKD: DHP	1X0XHSA, SINGLE FOUNTAIN MODELS	0510002219.D
APPROVED: JU	DATE: 07/08/24	SCALE: 1:32	DRAWING TYPE: INSTALLATION	REVISION: 1
			SIZE: A	SHEET 1 OF 11

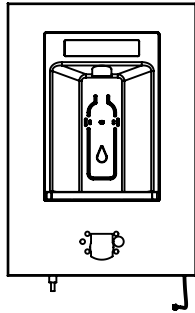

BOTTLE FILLER
(HS3 SHOWN FOR REFERENCE)

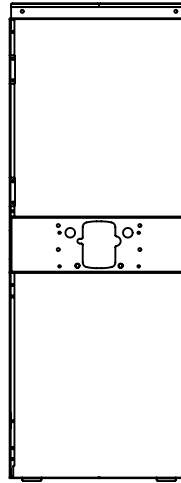

LOW SIDE
FRAME (HS11)

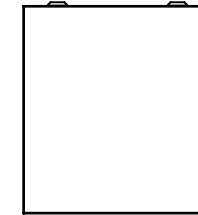

LOWER PANEL
(0410000921)



1001 FOUNTAIN (HS7)

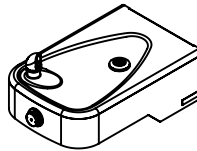

1107 FOUNTAIN (HS8)

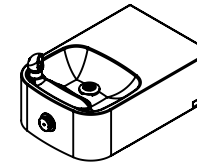

1109 FOUNTAIN (HS9)

HS MODEL #	BOTTLE FILLER	FRAME	FOUNTAIN	LOWER PANEL	LOOSE PARTS KIT
1001HSA	HS3	HS11	HS7	0410000921	HS101
1107HSA	HS5	HS11	HS8	0410000921	HS101
1109HSA	HS5	HS11	HS9	0410000921	HS101



1455 KLEPPE LANE
SPARKS, NEVADA 89431
(775) 359-4712 FAX (775) 359-7424
E-MAIL: HAWS@HAWSO.COM
WEBSITE: WWW.HAWSO.COM

ECN: 6000	REV. ECN: 6000	BY: DHP	MODEL(S) 1X0XHSA, SINGLE FOUNTAIN MODELS	PART NUMBER 0510002219.D
DRAWN: DHP	DATE: 12/15/22	CHKD: DHP		REVISION 1
APPROVED: JU	DATE: 07/08/24	SCALE: 1:20	DRAWING TYPE: INSTALLATION	SIZE: A

3. ROUGH IN WALL CAVITY WITH DIMENSIONS SHOWN. ROUGH IN ELECTRICAL, WASTE PIPING, AND WATER SUPPLY AS REQUIRED. BE SURE ELECTRICAL, WASTE PIPING, AND WATER SUPPLY IS CLEAR OF THE INSTALLED LOCATION OF THE IN WALL FRAME, AND BOTTLE FILLER.

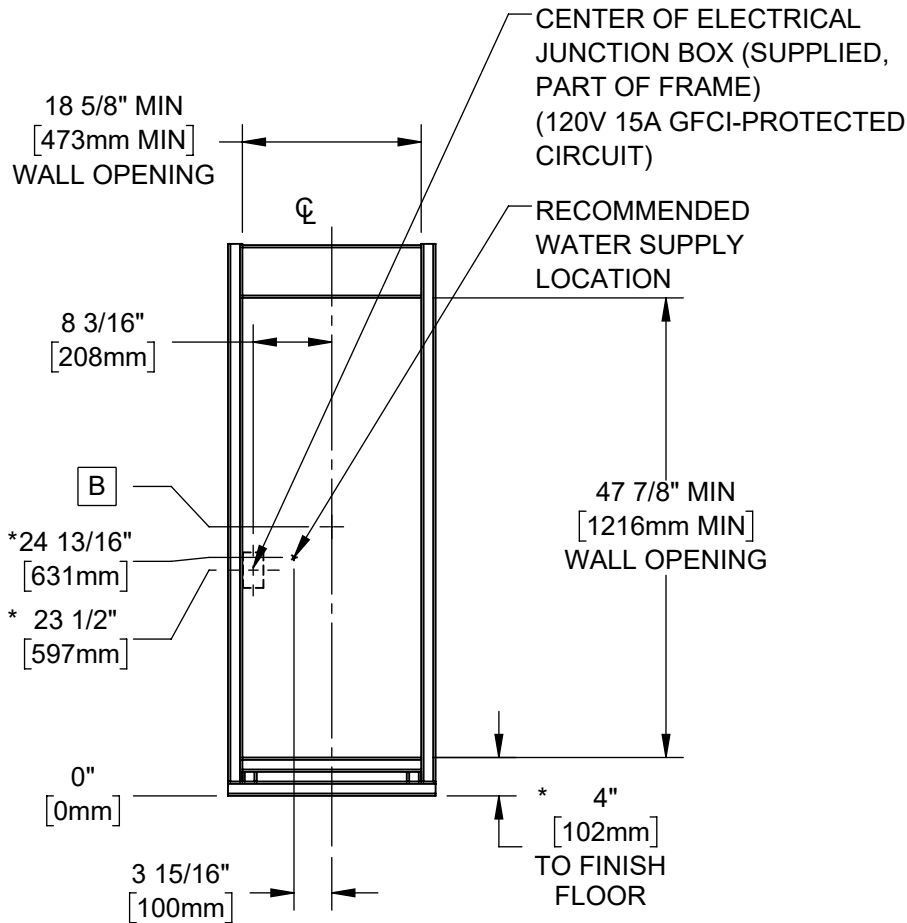

TYPICAL WALL OPENING

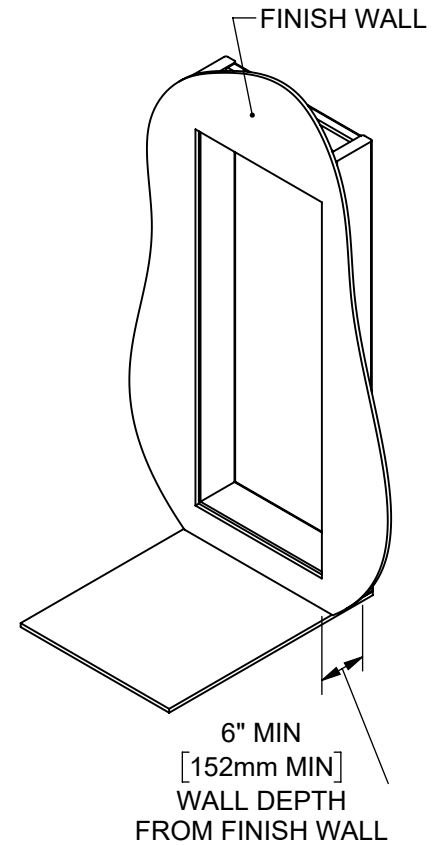

	B	
FOUNTAIN MODELS	DRAIN HEIGHT	WASTE BEND SIZE
1001/1011	28" [711mm]	1-1/4"
1107/1117	*27 5/16" [694mm]	1-1/4"
1109/1119	28 1/4" [718mm]	1-1/4"



Haws[®]

Since 1906

1455 KLEPPE LANE
SPARKS, NEVADA 89431
(775) 359-4712 FAX (775) 359-7424
E-MAIL: HAWS@HAWSO.COM
WEBSITE: WWW.HAWSO.COM

ECN: 6000	REV. ECN: 6000	BY: DHP	MODEL(S)	PART NUMBER
DRAWN: DHP	DATE: 12/15/22	CHKD: DHP	1X0XHSA, SINGLE FOUNTAIN MODELS	0510002219.D
APPROVED: JU	DATE: 07/08/24	SCALE: 1:20	DRAWING TYPE: INSTALLATION	REVISION
				1
			SIZE: A	SHEET 3 OF 11

4. INSTALL 4X PANEL CLIPS (DETAIL A) USING #10 NUTS (SUPPLIED).
5. MOUNT FRAME ASSEMBLY INTO WALL CAVITY USING 12X STRUCTURAL SCREWS (NOT SUPPLIED), USE SHIMS AS NEEDED AND ENSURE THE FRAME IS SQUARE.

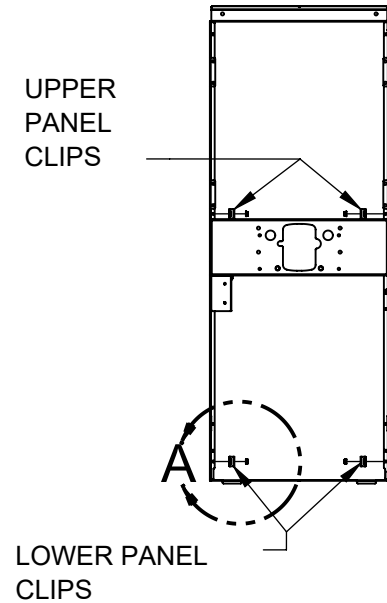
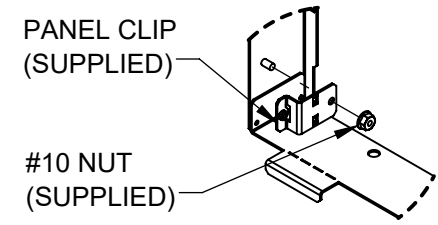
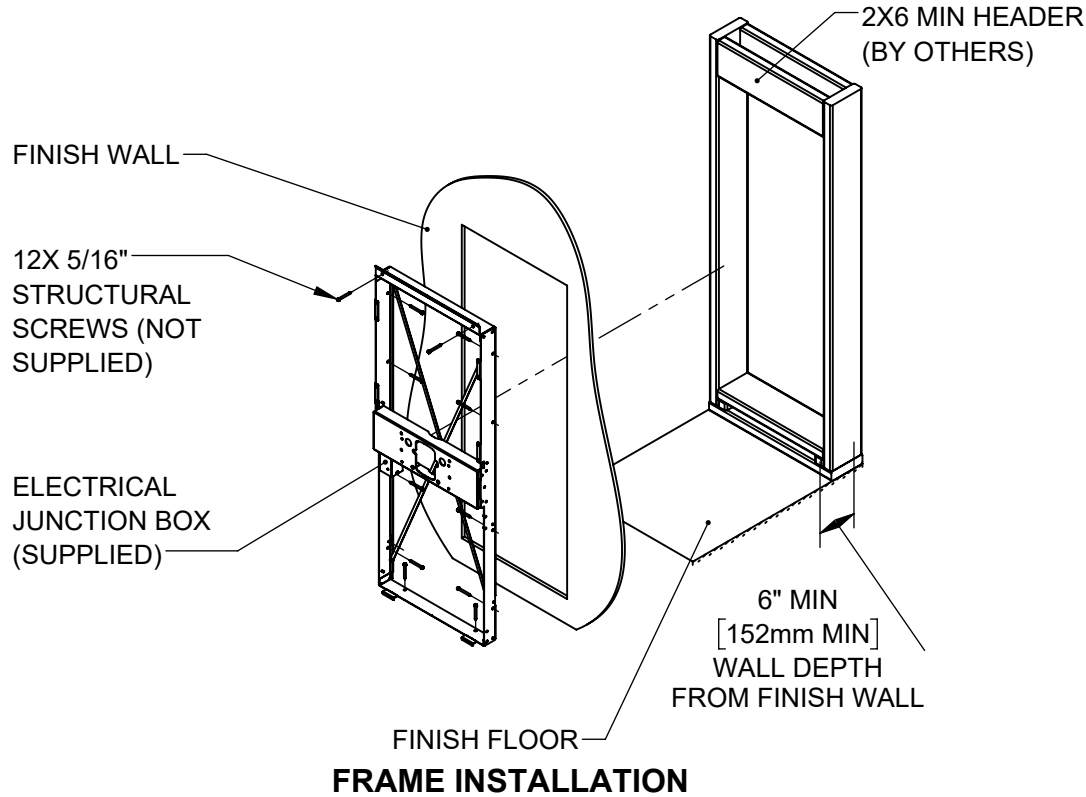

		1455 KLEPPE LANE SPARKS, NEVADA 89431 (775) 359-4712 FAX (775) 359-7424 E-MAIL: HAWS@HAWSO.COM WEBSITE: WWW.HAWSO.COM	
		ECN: 6000 DRAWN: DHP APPROVED: JU	REV. ECN: 6000 DATE: 12/15/22 DATE: 07/08/24
SCALE: 1:20 DRAWING TYPE: INSTALLATION SIZE: A			PART NUMBER: 0510002219.D REVISION: 1 SHEET 4 OF 11

6. REMOVE SHIPPING BRACKETS FROM FRAME (DETAIL B).
7. INSTALL FILTER HEAD USING 3X SUPPLIED #10 NUTS (DETAIL C).
8. (1001HSA ONLY) INSTALL 1001 DRINKING FOUNTAIN ADAPTERS USING 2X SUPPLIED 3/8" NUTS (DETAIL D). ENSURE THE CORRECT ORIENTATION OF THE ADAPTER PLATE, "FRONT" IS PRINTED ON THE ADAPTER PLATE AND SHOULD BE ORIENTED TOWARDS THE FINISH WALL.

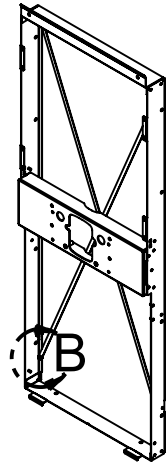

REMOVE SHIPPING CROSS BRACING

DETAIL B
(4 PLACES)

SHIPPING CROSS BRACE REMOVAL

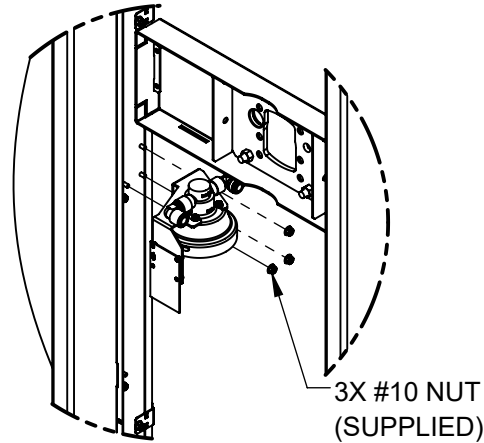

DETAIL C
FILTER/STRAINER HEAD INSTALL
(ALL MODELS)

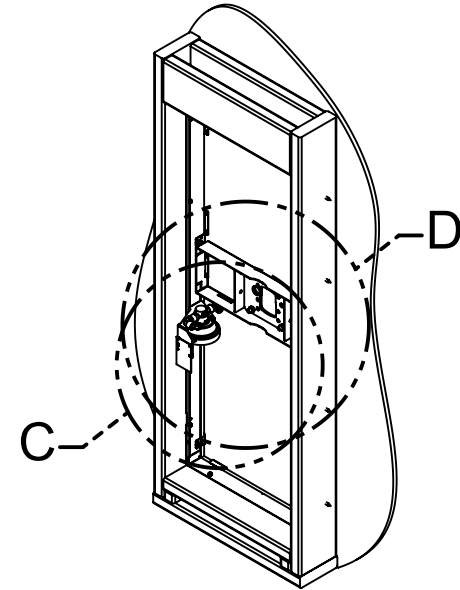

REAR VIEW

2X 3/8" NUT
(SUPPLIED)

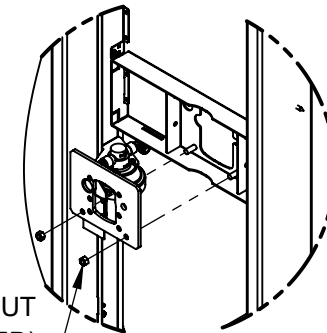

DETAIL D
1001 FOUNTAIN ADAPTER PLATE (1001/1011 MODELS ONLY)



Haws
Since 1906

1455 KLEPPE LANE
SPARKS, NEVADA 89431
(775) 359-4712 FAX (775) 359-7424
E-MAIL: HAWS@HAWS.CO.COM
WEBSITE: WWW.HAWS.CO.COM

ECN: 6000	REV. ECN: 6000	BY: DHP	MODEL(S) 1X0XHSA, SINGLE FOUNTAIN MODELS	PART NUMBER 0510002219.D
DRAWN: DHP	DATE: 12/15/22	CHKD: DHP		REVISION 1
APPROVED: JU	DATE: 07/08/24	SCALE: 1:20	DRAWING TYPE: INSTALLATION	SIZE: A
				SHEET 5 OF 11

9. INSTALL 4X 3/8" DRINKING FOUNTAIN BOLTS (SUPPLIED) FROM THE BACK SIDE OF THE FRAME.
10. HANG THE BOTTLE FILLER FROM THE TOP OF THE FRAME AND ALIGN THE PANEL SO THE 3/8" DRINKING FOUNTAIN BOLTS PROTRUDE THROUGH THE PANEL. INSTALL THE 2X #8 PANEL SCREWS (SUPPLIED) ON EITHER SIDE OF THE BOTTLE FILLER PANEL.
11. CONNECT THE FILTER CABLE (RIGHT SIDE OF THE BOTTLE FILLER) TO THE FILTER TRACKING BOARD.

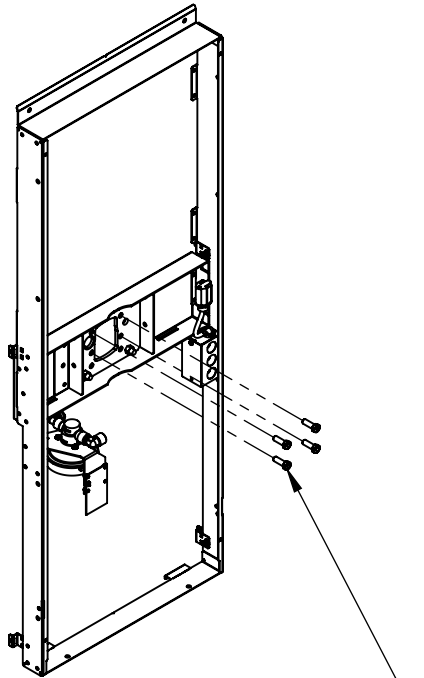

4X DRINKING FOUNTAIN BOLTS (SUPPLIED). USE WASHERS (SUPPLIED) UNDER HEAD OF BOLTS FOR 1107/1117 AND 1109/1119 MODELS

REAR VIEW

2X #8-32 BUTTON HEAD PANEL SCREWS (SUPPLIED)

FILTER CABLE

HANG BOTTLE FILLER FROM TOP OF FRAME

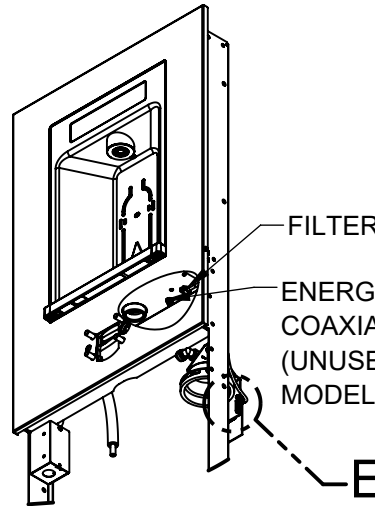
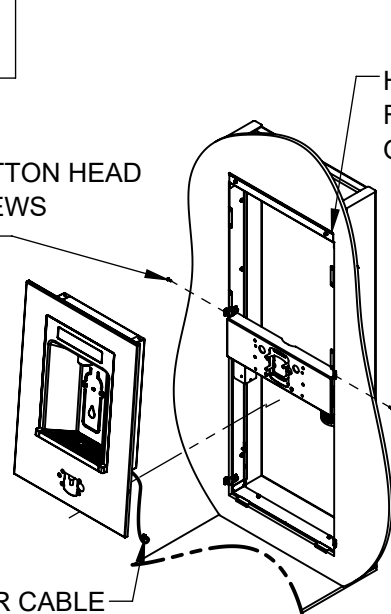

FILTER CABLE
ENERGY SAVINGS COAXIAL RECEPTACLE (UNUSED, CHILLED MODELS ONLY)

E

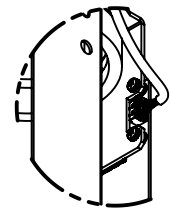
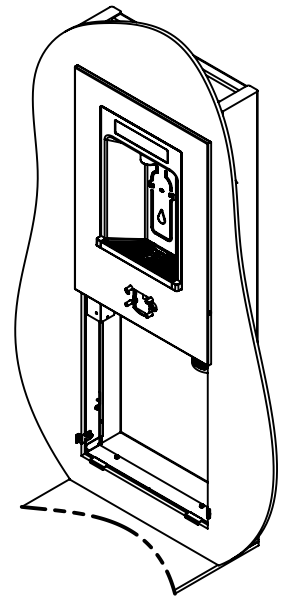

DETAIL E
FILTER TRACKING ELECTRICAL CONNECTION

 Haws Since 1906		1455 KLEPPE LANE SPARKS, NEVADA 89431 (775) 359-4712 FAX (775) 359-7424 E-MAIL: HAWS@HAWSO.COM WEBSITE: WWW.HAWSO.COM	
		ECN: 6000 DRAWN: DHP APPROVED: JU	REV. ECN: 6000 DATE: 12/15/22 DATE: 07/08/24
			PART NUMBER 0510002219.D REVISION 1
SCALE: 1:14 DRAWING TYPE: INSTALLATION SIZE: A		SHEET 6 OF 11	

NOTE: STEP 12 CAN BE PERFORMED LATER IN INSTALLATION IF DESIRED.

12. HAVE AN ELECTRICIAN CONNECT A 120VAC/60HZ 15-AMP GFCI-PROTECTED CIRCUIT TO THE RESPECTIVE LINE, NEUTRAL, AND GROUND CONNECTIONS INSIDE THE BOTTLE FILLER JUNCTION BOX VIA ONE OF THE AVAILABLE 1/2" KNOCKOUTS.

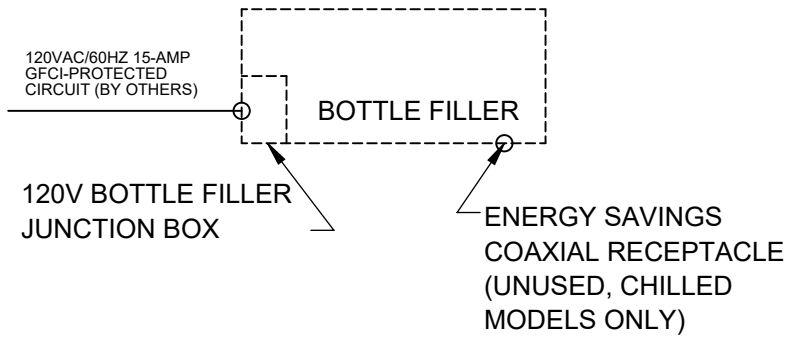

ELECTRICAL WIRING OVERVIEW

BOTTLE FILLER JUNCTION BOX

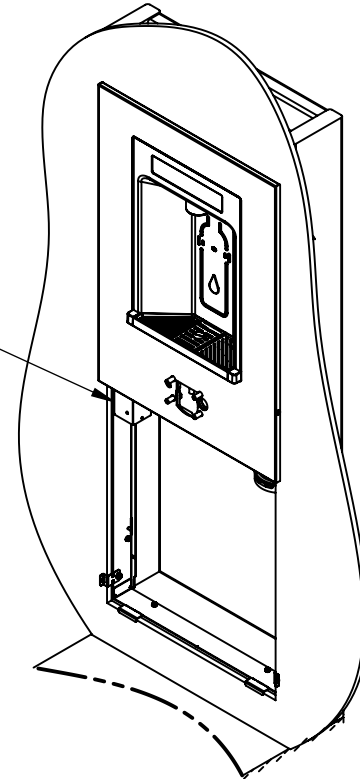

 Haws Since 1906			1455 KLEPPE LANE SPARKS, NEVADA 89431 (775) 359-4712 FAX (775) 359-7424 E-MAIL: HAWS@HAWS.CO.COM WEBSITE: WWW.HAWS.CO.COM			
			ECN: 6000 DRAWN: DHP APPROVED: JU	REV. ECN: 6000 DATE: 12/15/22 DATE: 07/08/24	BY: DHP CHKD: DHP	MODEL(S) 1X0XHSA, SINGLE FOUNTAIN MODELS
SCALE: 1:20			DRAWING TYPE: INSTALLATION		SIZE: A	SHEET 7 OF 11

13. MOUNT THE DRINKING FOUNTAIN TO THE PROTRUDING 3/8" STUDS FROM STEP 9. INSTALL 4X 3/8" NUTS (SUPPLIED) AND TIGHTEN FULLY (25 LB-FT).
14. INSTALL THE WASTE BEND (SUPPLIED), CUT TO LENGTH AS REQUIRED. REFER TO SHEET 3 FOR DRAIN HEIGHTS FOR EACH MODEL. SET LOWER COVER AND #8 PAN HEAD SCREWS ASIDE, THESE WILL BE INSTALLED ONCE THE WATER SUPPLY PLUMBING IS COMPLETE.

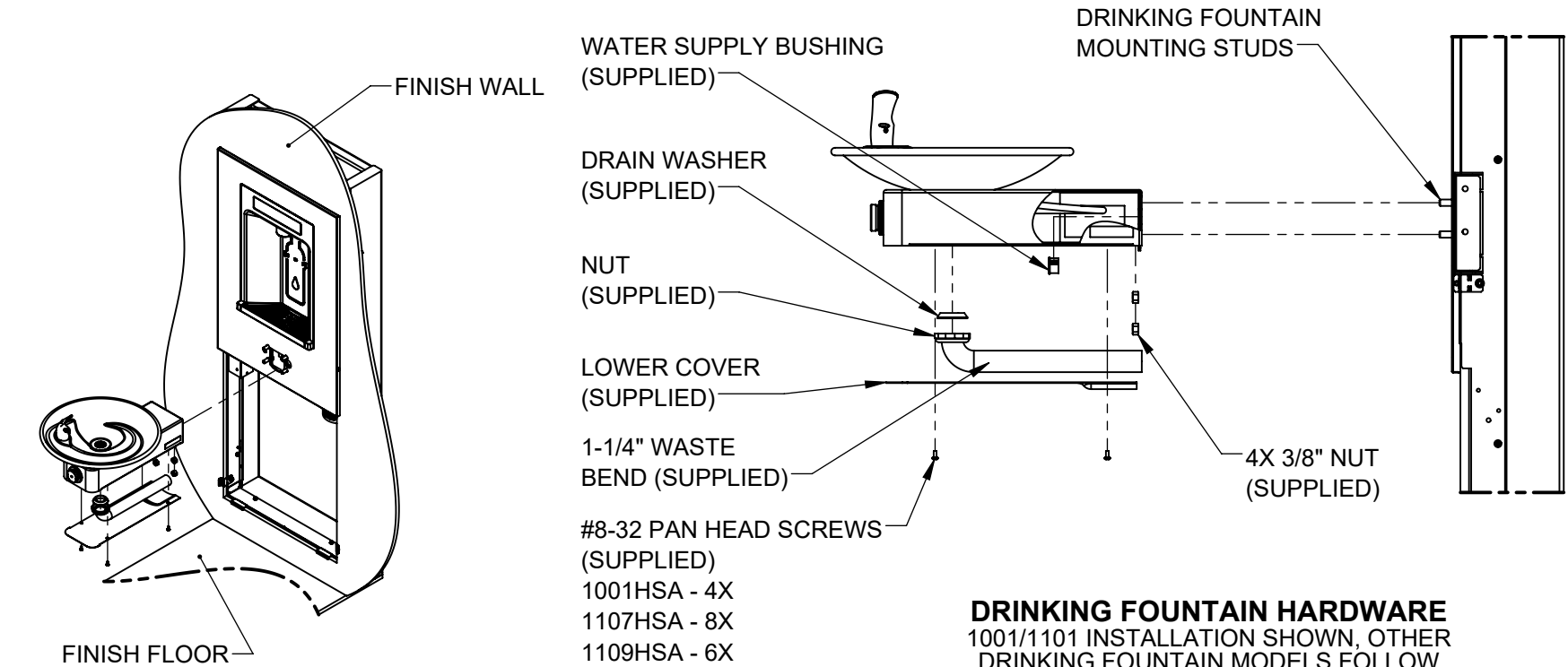

DRINKING FOUNTAIN HARDWARE
 1001/1101 INSTALLATION SHOWN, OTHER DRINKING FOUNTAIN MODELS FOLLOW THE SAME INSTALLATION STEPS AND CONTAIN SIMILAR PARTS.

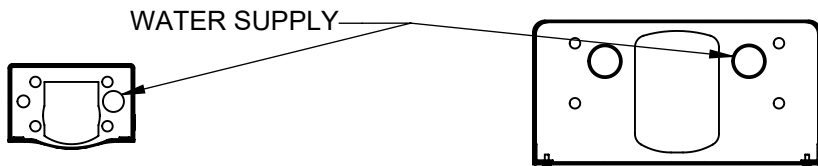

**1001/1101
HOLE
PATTERN**

**1107/1117 &
1109/1119 HOLE
PATTERN**

 Haws Since 1906		1455 KLEPPE LANE SPARKS, NEVADA 89431 (775) 359-4712 FAX (775) 359-7424 E-MAIL: HAWS@HAWS.CO.COM WEBSITE: WWW.HAWS.CO.COM	
		ECN: 6000 DRAWN: DHP APPROVED: JU	REV. ECN: 6000 DATE: 12/15/22 DATE: 07/08/24
PART NUMBER 0510002219.D			REVISION 1
SCALE: 1:20		DRAWING TYPE: INSTALLATION	SIZE: A SHEET 8 OF 11

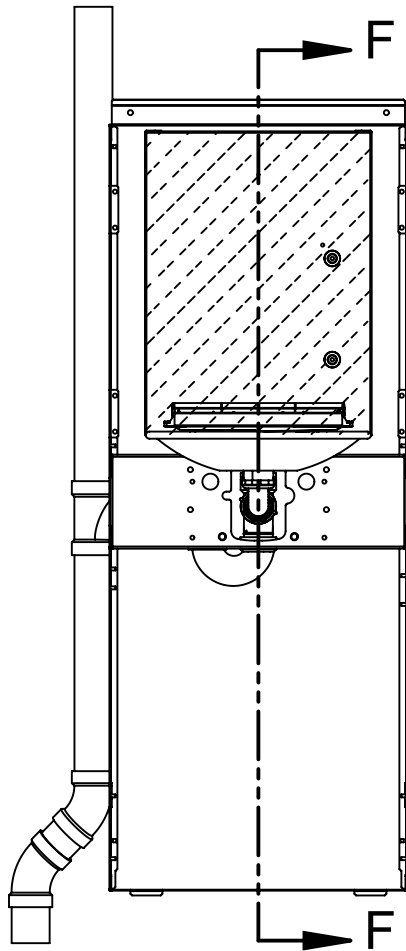

FRONT VIEW
(SOME COMPONENTS HIDDEN FOR CLARITY)

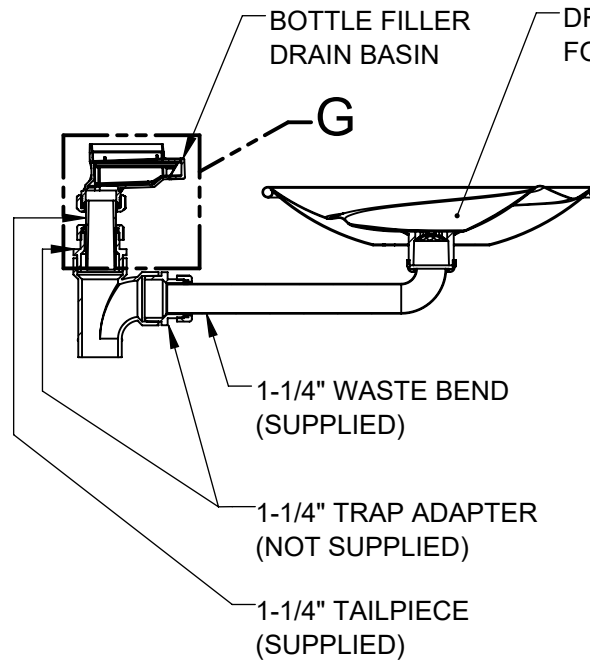

**SECTION F-F
(ENLARGED)**

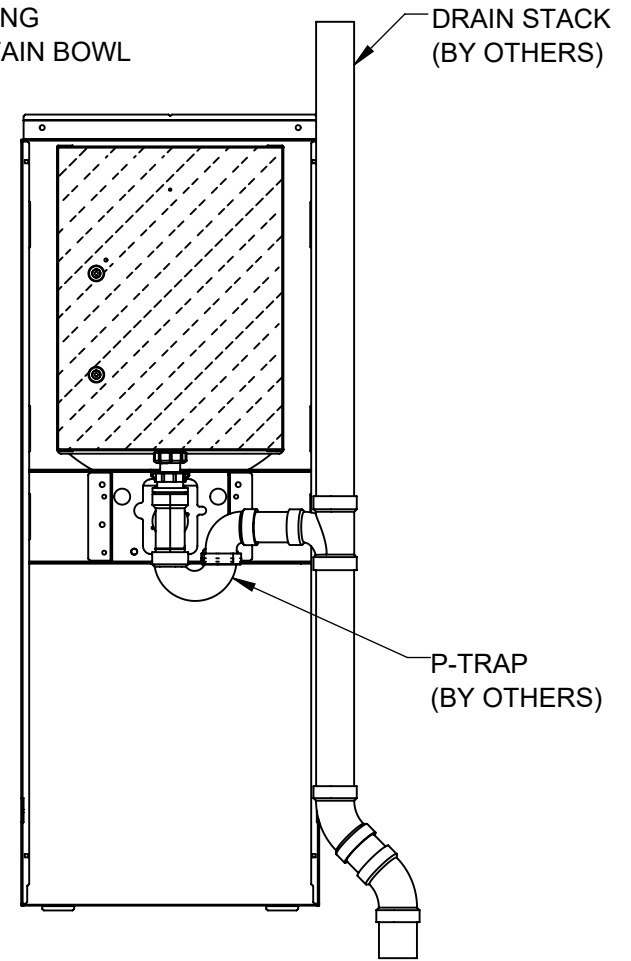

BACK VIEW
(SOME COMPONENTS HIDDEN FOR CLARITY)

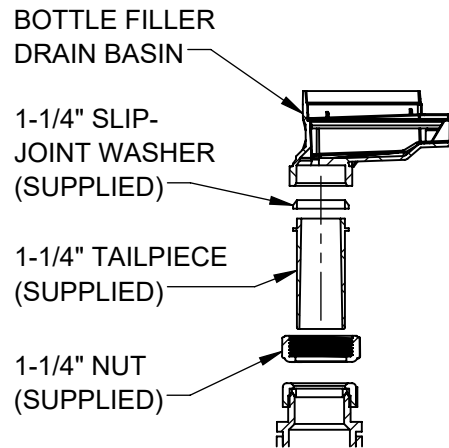

**DETAIL G
(EXPLODED VIEW)**

FOR REFERENCE ONLY

DRAIN STACK SHOWN AS REFERENCE ONLY. LOCAL, STATE, OR FEDERAL CODES SHOULD BE ADHERED TO FOR PROPER DRAIN INSTALLATION.

		1455 KLEPPE LANE SPARKS, NEVADA 89431 (775) 359-4712 FAX (775) 359-7424 E-MAIL: HAWS@HAWS.CO.COM WEBSITE: WWW.HAWS.CO.COM	
		ECN: 6000 DRAWN: DHP APPROVED: JU	REV. ECN: 6000 DATE: 12/15/22 DATE: 07/08/24
PART NUMBER 0510002219.D			REVISION 1
SHEET 9 OF 11			DRAWING TYPE: INSTALLATION

15. INSTALL 3/8" TUBING AS SHOWN. NOTE DIRECTION OF FLOW ARROWS ON FILTER AND PRESSURE REDUCING VALVE. CUT ALL TUBING AND INSULATION AS REQUIRED, ENSURE TUBING IS CUT SQUARE AND FULLY INSERTED INTO PUSH-TO-CONNECT FITTINGS.

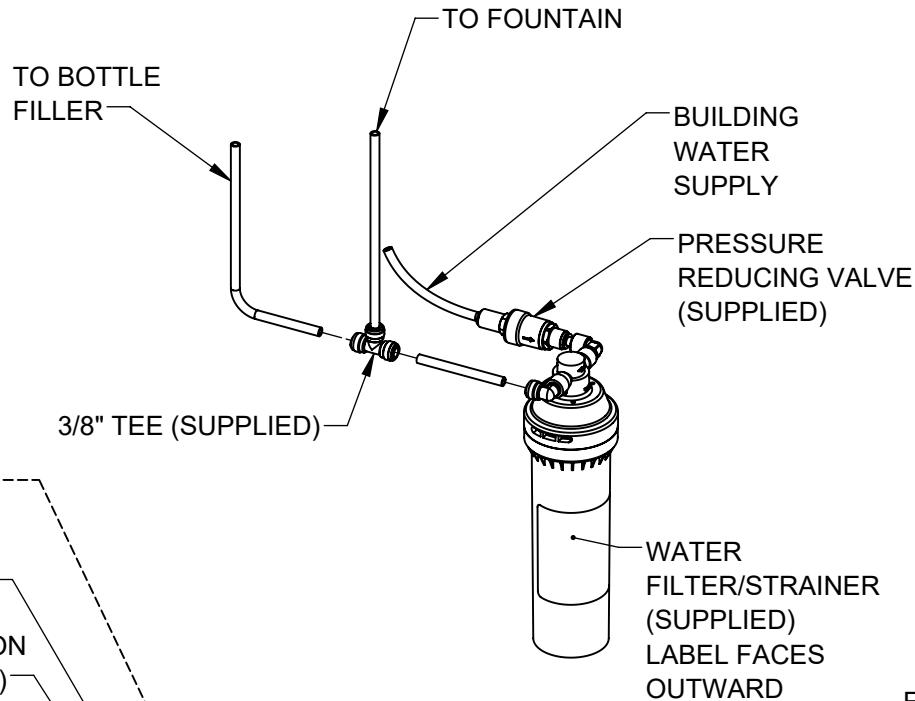

WATERWAY DIAGRAM

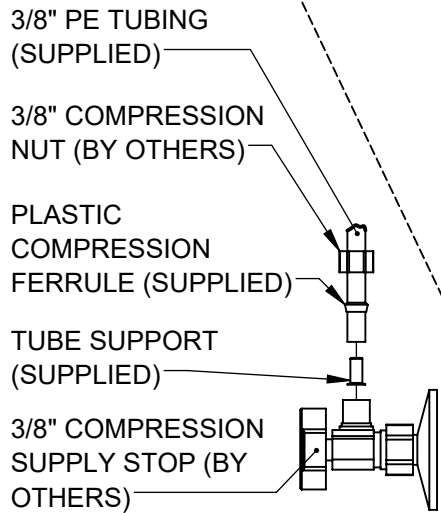

WATER SUPPLY CONNECTION

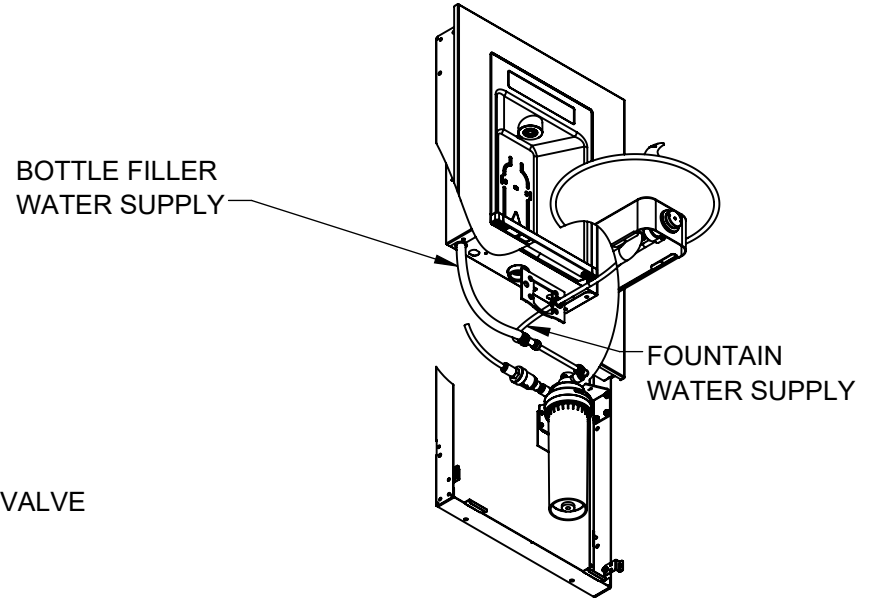

WATERWAY LAYOUT
(SOME COMPONENTS HIDDEN FOR CLARITY)

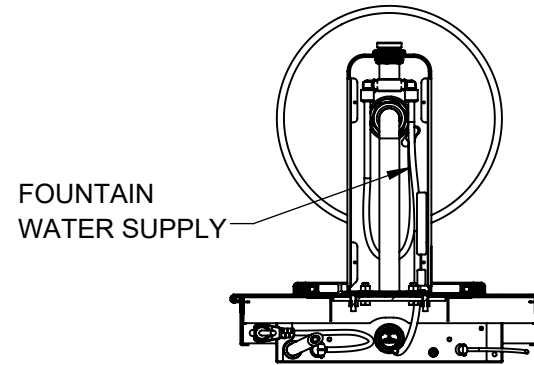

BOTTOM VIEW
(SOME COMPONENTS HIDDEN FOR CLARITY)



1455 KLEPPE LANE
SPARKS, NEVADA 89431
(775) 359-4712 FAX (775) 359-7424
E-MAIL: HAWS@HAWS.CO.COM
WEBSITE: WWW.HAWS.CO.COM

ECN: 6000	REV. ECN: 6000	BY: DHP	MODEL(S) 1X0XHSA, SINGLE FOUNTAIN MODELS	PART NUMBER 0510002219.D
DRAWN: DHP	DATE: 12/15/22	CHKD: DHP		REVISION 1
APPROVED: JU	DATE: 07/08/24	SCALE: 1:16	DRAWING TYPE: INSTALLATION	SIZE: A

16. CONNECT THE NEMA 5-15P BOTTLE FILLER PLUG TO THE NEMA 5-15R RECEPTACLE. VERIFY THAT THE BOTTLE FILLER DISPLAY HAS POWERED ON.
17. INSTALL THE FILTER CARTRIDGE INTO THE FILTER HEAD.
18. MOUNT THE LOWER PANEL USING 2X #8 PANEL SCREWS (SUPPLIED).
19. INSTALL DRINKING FOUNTAIN LOWER COVER WITH 4X #8 PAN HEAD SCREWS (SUPPLIED).

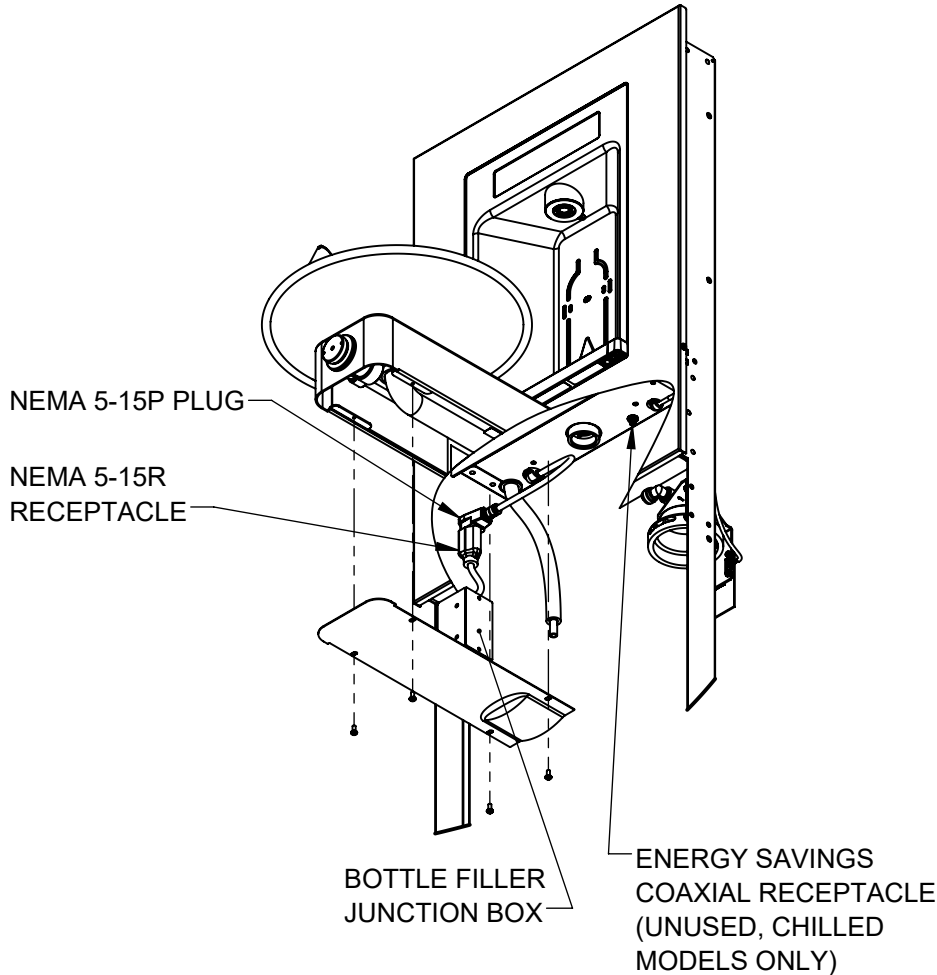

ELECTRICAL CONNECTIONS AND DRINKING FOUNTAIN LOWER COVER
(SOME COMPONENTS HIDDEN FOR CLARITY)

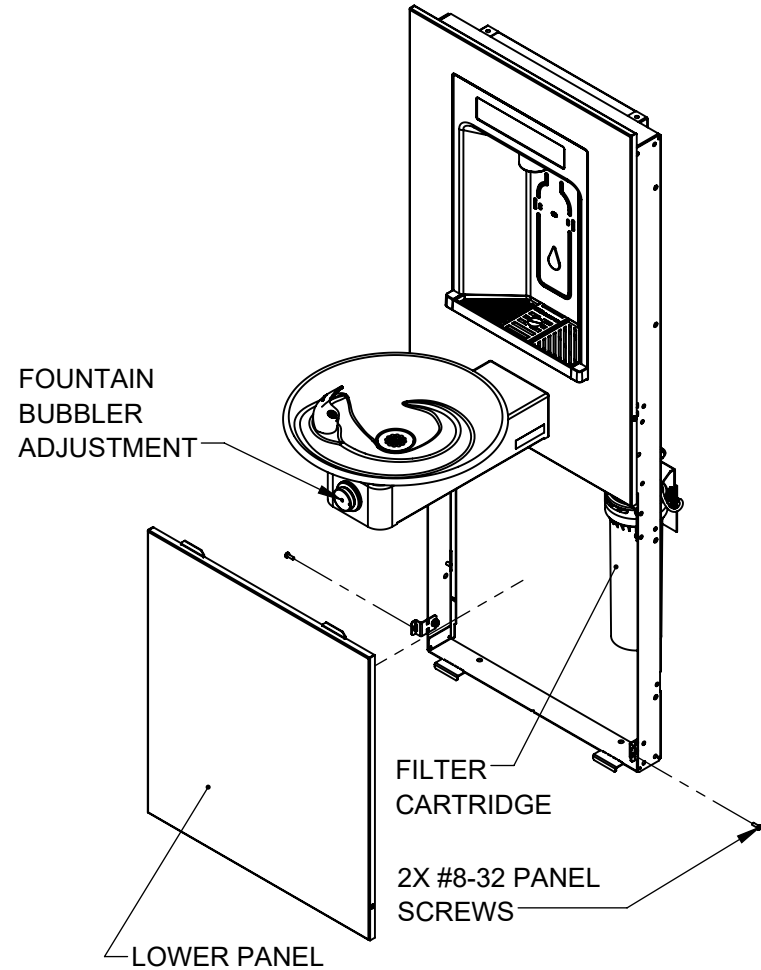

LOWER PANEL INSTALLATION

 Haws Since 1906		1455 KLEPPE LANE SPARKS, NEVADA 89431 (775) 359-4712 FAX (775) 359-7424 E-MAIL: HAWS@HAWS.CO.COM WEBSITE: WWW.HAWS.CO.COM	
		ECN: 6000 DRAWN: DHP APPROVED: JU	REV. ECN: 6000 DATE: 12/15/22 DATE: 07/08/24
PART NUMBER 0510002219.D			REVISION 1
SCALE: 1:12 DRAWING TYPE: INSTALLATION		SIZE: A SHEET 11 OF 11	