

NOTES:

1. ACCESS TO THE BACK SIDE OF THE WALL IS REQUIRED TO INSTALL AND MAINTAIN 1X0XH5 MODELS. THESE MODELS ARE SUITABLE FOR WALLS WITH DRYWALL (5/8" MAX) SHEATHING ONLY.
2. HOLD ROUGH-IN DIMENSIONS $\pm 1/4"$ (6.4mm).
3. WHEN INSTALLING THIS UNIT, LOCAL, STATE, OR FEDERAL CODES SHOULD BE ADHERED TO. FOR CHILD-HEIGHT INSTALLATIONS ON 1107 MODELS, REDUCE DIMENSIONS MARKED (*) BY 3" [76mm]. INSTALL A TRAP IN THE WASTE LINE AND A SCREWDRIVER STOP IN THE SUPPLY LINE IF REQUIRED.

	A	B	
FOUNTAIN MODELS	BUBBLER HEIGHT	DRAIN HEIGHT	WASTE BEND SIZE
1001/1011	33 13/16" [858mm]	28" [711mm]	1-1/4"
1107/1117	*32 13/16" [834mm]	*27 5/16" [694mm]	1-1/4"
1109/1119	34 7/16" [875mm]	28 1/4" [718mm]	1-1/4"

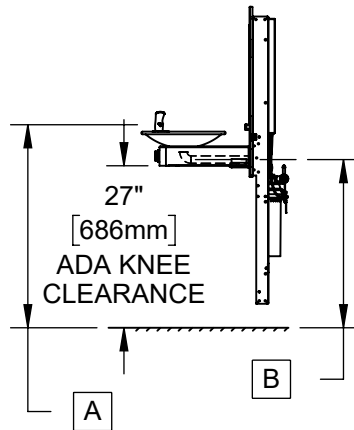
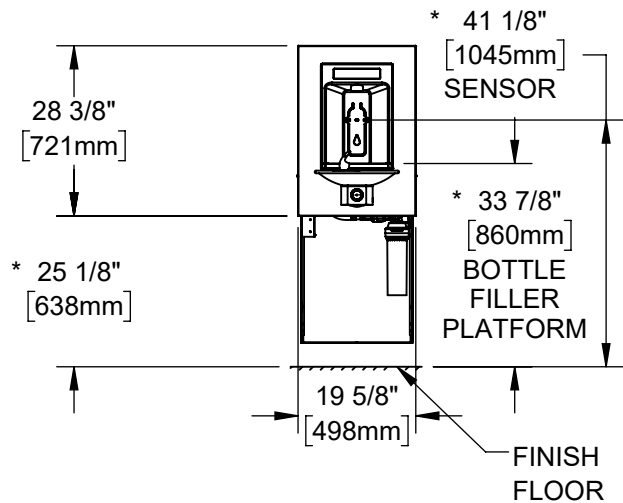
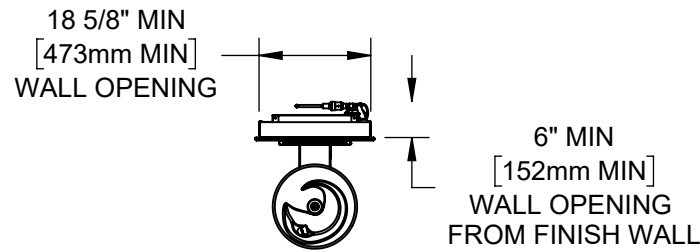

1001HS

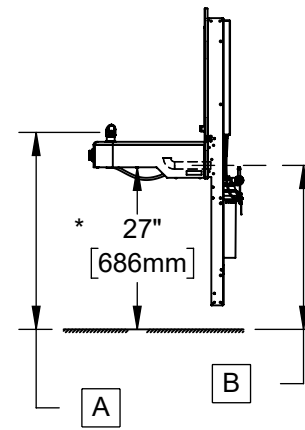

1107HS

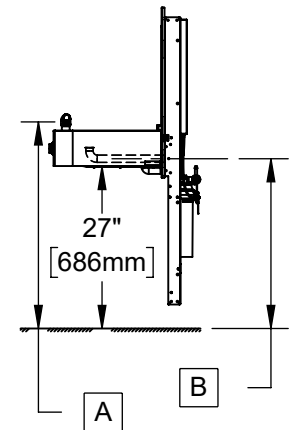

1109HS

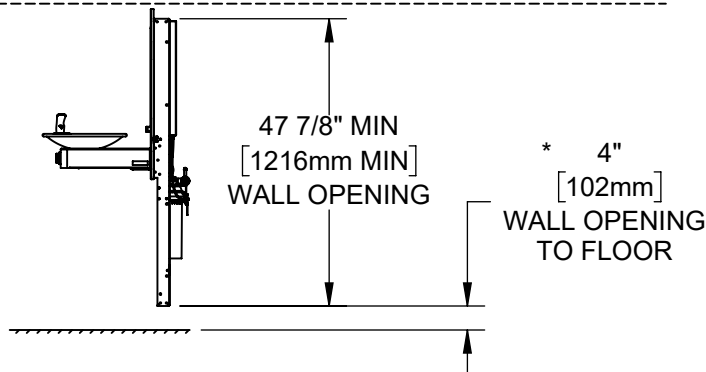

1455 KLEPPE LANE
SPARKS, NEVADA 89431
(775) 359-4712 FAX (775) 359-7424
E-MAIL: HAWS@HAWS.CO.COM
WEBSITE: WWW.HAWS.CO.COM

ECN: 6000	REV. ECN: 6000	BY: DHP	MODEL(S) 1X0XH5, SINGLE FOUNTAIN MODELS, REAR ACCESS	PART NUMBER 0510002220.D
DRAWN: DHP	DATE: 12/15/22	CHKD: DHP		REVISION 1
APPROVED: JU	DATE: 07/08/24	SCALE: 1:32	DRAWING TYPE: INSTALLATION	SIZE: A SHEET 1 OF 11

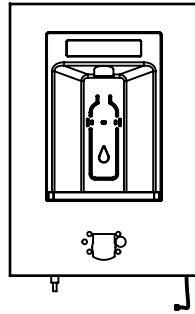

BOTTLE FILLER
(HS3 SHOWN FOR REFERENCE)

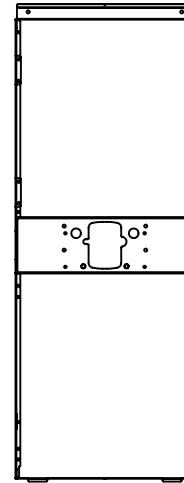

FRAME (HS11)



1001 FOUNTAIN (HS7)

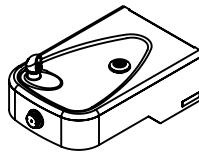

1107 FOUNTAIN (HS8)

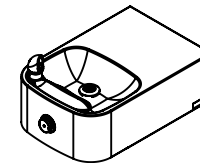

1109 FOUNTAIN (HS9)

HS MODEL #	BOTTLE FILLER	FRAME	FOUNTAIN	LOOSE PARTS KIT
1001HS	HS3	HS11	HS7	HS105
1107HS	HS5	HS11	HS8	HS105
1109HS	HS5	HS11	HS9	HS105



1455 KLEPPE LANE
SPARKS, NEVADA 89431
(775) 359-4712 FAX (775) 359-7424
E-MAIL: HAWS@HAWS.CO.COM
WEBSITE: WWW.HAWS.CO.COM

ECN: 6000	REV. ECN: 6000	BY: DHP	MODEL(S) 1X0XHS, SINGLE FOUNTAIN MODELS, REAR ACCESS	PART NUMBER 0510002220.D
DRAWN: DHP	DATE: 12/15/22	CHKD: DHP		REVISION 1
APPROVED: JU	DATE: 07/08/24	SCALE: 1:20	DRAWING TYPE: INSTALLATION	SIZE: A SHEET 2 OF 11

4. ROUGH IN WALL CAVITY WITH DIMENSIONS SHOWN. ROUGH IN ELECTRICAL, WASTE PIPING, AND WATER SUPPLY AS REQUIRED

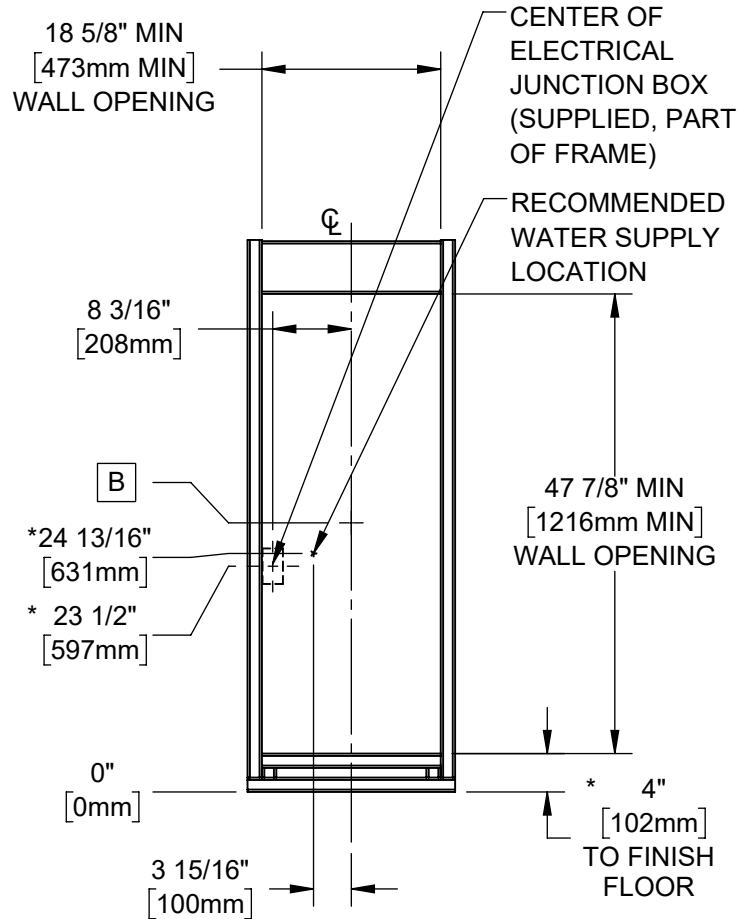

TYPICAL WALL OPENING

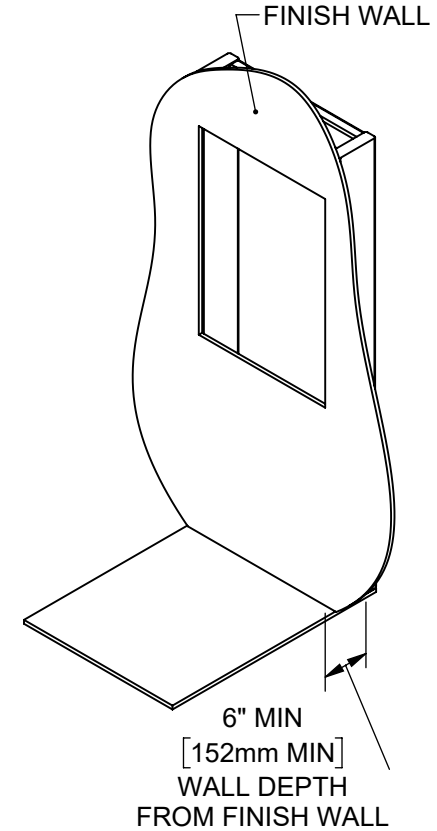

	B	
FOUNTAIN MODELS	LOW SIDE DRAIN	WASTE BEND SIZE
1001/1011	28" [711mm]	1-1/4"
1107/1117	*27 5/16" [694mm]	1-1/4"
1109/1119	28 1/4" [718mm]	1-1/4"



Haws[®]

Since 1906

1455 KLEPPE LANE
SPARKS, NEVADA 89431
(775) 359-4712 FAX (775) 359-7424
E-MAIL: HAWS@HAWSO.COM
WEBSITE: WWW.HAWSO.COM

ECN: 6000	REV. ECN: 6000	BY: DHP	MODEL(S): 1X0XH5, SINGLE FOUNTAIN MODELS, REAR ACCESS	PART NUMBER: 0510002220.D
DRAWN: DHP	DATE: 12/15/22	CHKD: DHP		REVISION: 1
APPROVED: JU	DATE: 07/08/24	SCALE: 1:20	DRAWING TYPE: INSTALLATION	SHEET 3 OF 11

5. REMOVE 2X DRYWALL TABS FROM THE BOTTOM OF THE FRAMES BY BENDING ALONG PERFORATIONS (DETAIL A).
6. MOUNT FRAME ASSEMBLY INTO WALL CAVITY FROM THE BACK SIDE OF THE FINISH WALL USING 12X STRUCTURAL SCREWS (NOT SUPPLIED), USE SHIMS AS NEEDED AND ENSURE THE FRAME IS SQUARE.
7. INSTALL THE 2X PANEL CLIPS USING #10 NUTS (SUPPLIED) AS SHOWN (DETAIL B).

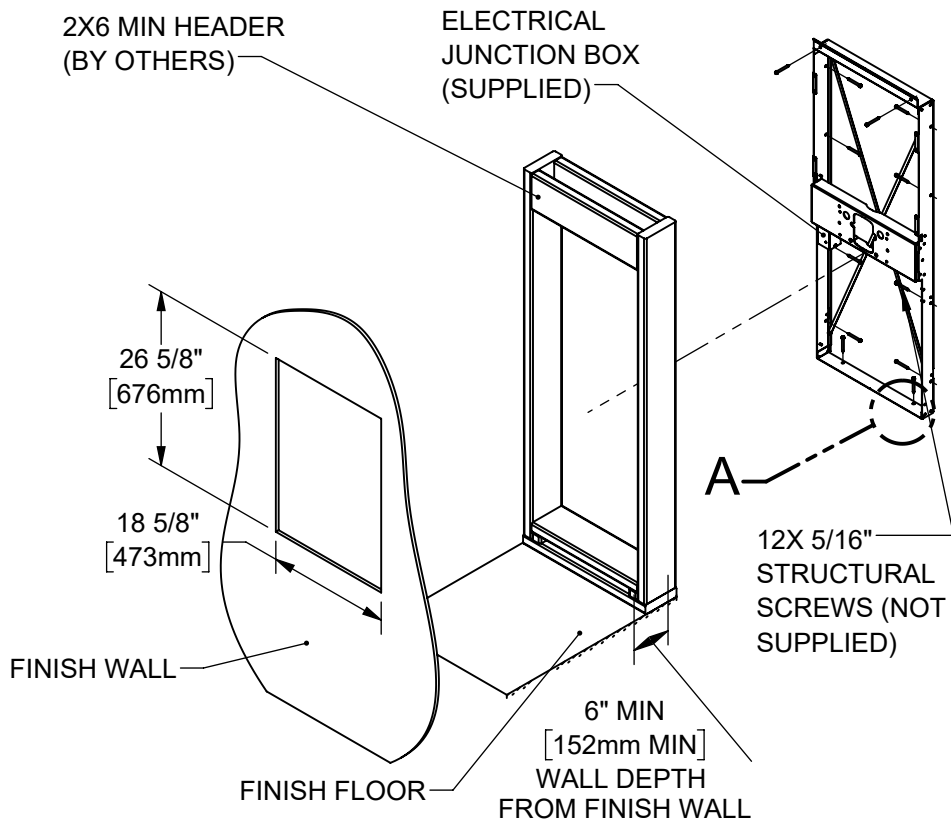

FRAME INSTALLATION

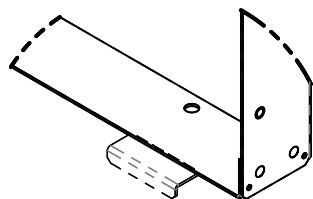

**DETAIL A
DRYWALL TAB REMOVAL
(4 PLACES)**

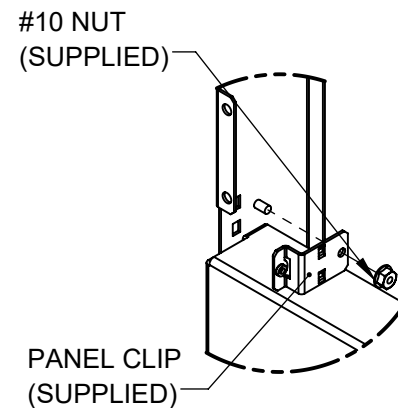

**DETAIL B
PANEL CLIP
INSTALL
(2 PLACES)**

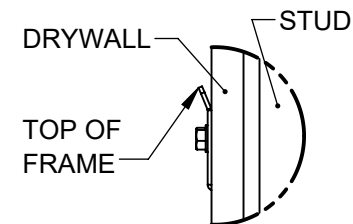
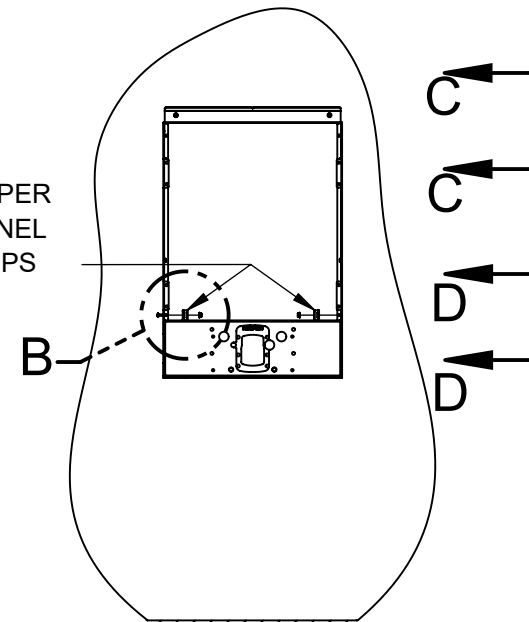

**VIEW ON C-C
(ENLARGED)**

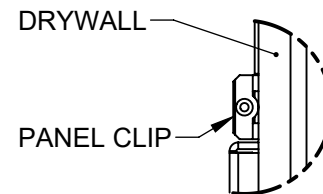

**VIEW ON D-D
(ENLARGED)**



1455 KLEPPE LANE
SPARKS, NEVADA 89431
(775) 359-4712 FAX (775) 359-7424
E-MAIL: HAWS@HAWSO.COM
WEBSITE: WWW.HAWSO.COM

ECN: 6000	REV. ECN: 6000	BY: DHP	MODEL(S) 1X0XHS, SINGLE FOUNTAIN MODELS, REAR ACCESS	PART NUMBER 0510002220.D
DRAWN: DHP	DATE: 12/15/22	CHKD: DHP		REVISION 1
APPROVED: JU	DATE: 07/08/24	SCALE: 1:20	DRAWING TYPE: INSTALLATION	SIZE: A

8. REMOVE SHIPPING BRACKETS FROM FRAME (DETAIL E).
9. INSTALL FILTER HEAD USING 3X SUPPLIED #10 NUTS (DETAIL F).
10. (1001HS ONLY) INSTALL 1001 DRINKING FOUNTAIN ADAPTERS USING 2X SUPPLIED 3/8" NUTS (DETAIL G).

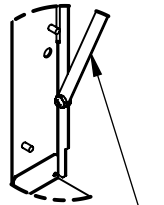
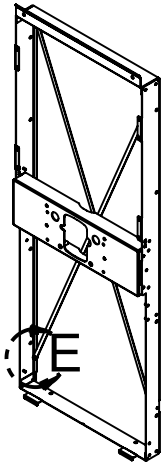

REMOVE SHIPPING
CROSS BRACING

DETAIL E
(4 PLACES)

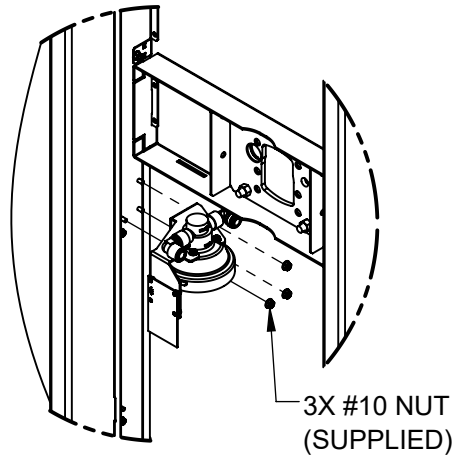

DETAIL F
FILTER/STRAINER HEAD INSTALL
(ALL MODELS)

3X #10 NUT
(SUPPLIED)

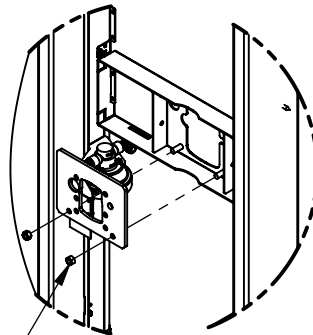

2X 3/8" NUT
(SUPPLIED)

DETAIL G
1001 FOUNTAIN ADAPTER PLATE (1001/1011
MODELS ONLY)

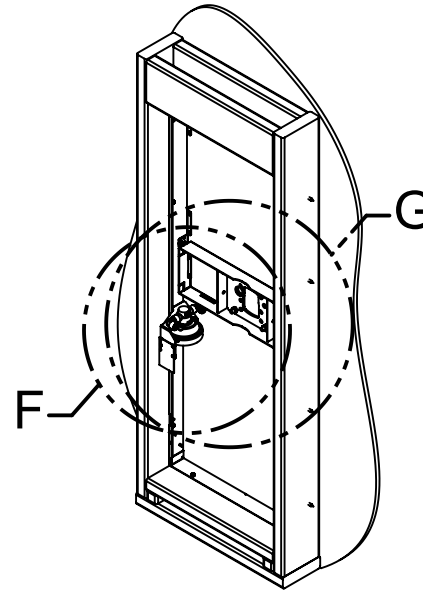

REAR VIEW



1455 KLEPPE LANE
SPARKS, NEVADA 89431
(775) 359-4712 FAX (775) 359-7424
E-MAIL: HAWS@HAWSO.COM
WEBSITE: WWW.HAWSO.COM

ECN: 6000	REV. ECN: 6000	BY: DHP	MODEL(S) 1X0XHS, SINGLE FOUNTAIN MODELS, REAR ACCESS	PART NUMBER 0510002220.D
DRAWN: DHP	DATE: 12/15/22	CHKD: DHP		REVISION 1
APPROVED: JU	DATE: 07/08/24	SCALE: 1:20	DRAWING TYPE: INSTALLATION	SIZE: A

11. INSTALL 4X 3/8" DRINKING FOUNTAIN BOLTS (SUPPLIED) FROM THE BACK SIDE OF THE FRAME.
12. HANG THE BOTTLE FILLER FROM THE TOP OF THE FRAME AND ALIGN THE PANEL SO THE 3/8" DRINKING FOUNTAIN BOLTS PROTRUDE THROUGH THE PANEL. INSTALL THE 2X #8 PANEL SCREWS (SUPPLIED) ON EITHER SIDE OF THE BOTTLE FILLER PANEL.
13. CONNECT THE FILTER CABLE (RIGHT SIDE OF THE BOTTLE FILLER) TO THE FILTER TRACKING BOARD.

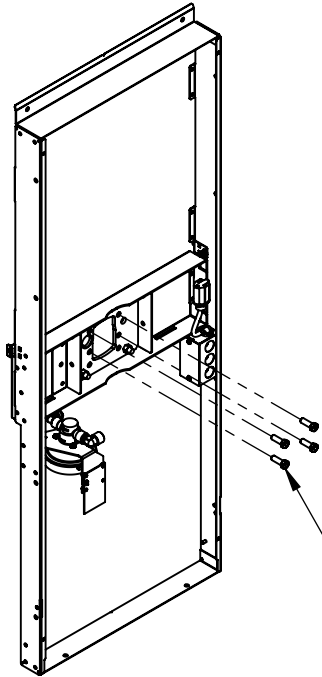

4X DRINKING FOUNTAIN BOLTS (SUPPLIED). USE WASHERS (SUPPLIED) UNDER HEAD OF BOLTS FOR 1107/1117 AND 1109/1119 MODELS

REAR VIEW

2X #8-32 BUTTON HEAD PANEL SCREWS (SUPPLIED)

FILTER CABLE

HANG BOTTLE FILLER FROM TOP OF FRAME

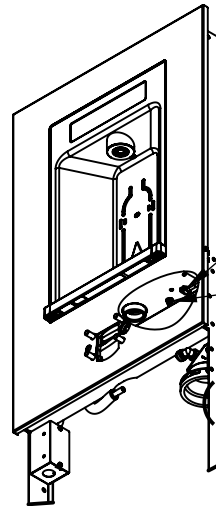
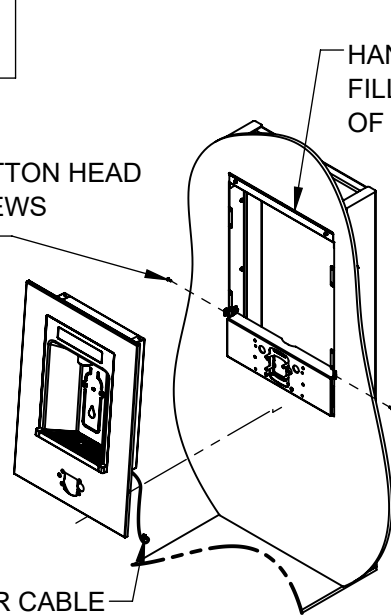

FILTER CABLE
ENERGY SAVINGS COAXIAL RECEPTACLE (UNUSED, CHILLED MODELS ONLY)

H

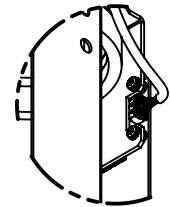
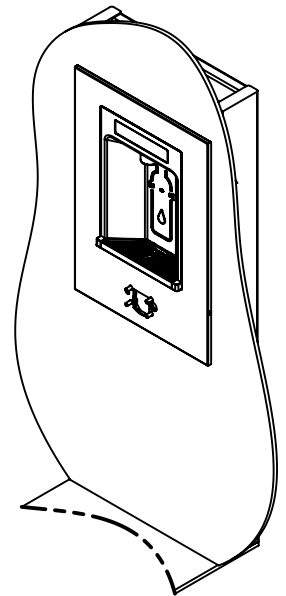

DETAIL H
FILTER TRACKING ELECTRICAL CONNECTION



1455 KLEPPE LANE
SPARKS, NEVADA 89431
(775) 359-4712 FAX (775) 359-7424
E-MAIL: HAWS@HAWSO.COM
WEBSITE: WWW.HAWSO.COM

ECN: 6000	REV. ECN: 6000	BY: DHP	MODEL(S) 1X0XH5, SINGLE FOUNTAIN MODELS, REAR ACCESS	PART NUMBER 0510002220.D
DRAWN: DHP	DATE: 12/15/22	CHKD: DHP		REVISION 1
APPROVED: JU	DATE: 07/08/24		SCALE: 1:14 DRAWING TYPE: INSTALLATION	SIZE: A SHEET 6 OF 11

NOTE: STEP 14 CAN BE PERFORMED LATER IN INSTALLATION IF DESIRED.

14. HAVE AN ELECTRICIAN CONNECT A 120VAC/60HZ 15-AMP GFCI-PROTECTED CIRCUIT TO THE RESPECTIVE LINE, NEUTRAL, AND GROUND CONNECTIONS INSIDE THE BOTTLE FILLER JUNCTION BOX VIA ONE OF THE AVAILABLE 1/2" KNOCKOUTS.

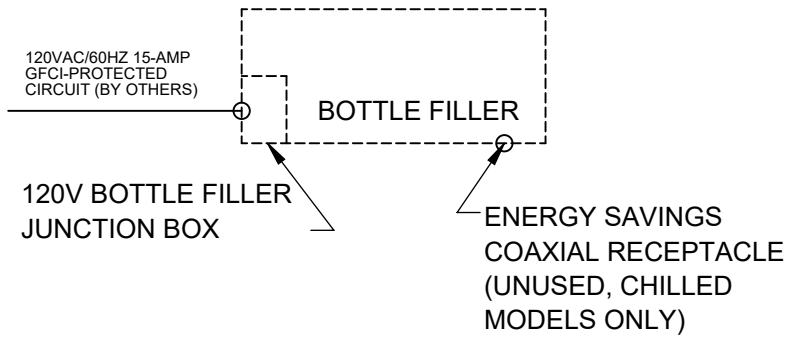

ELECTRICAL WIRING OVERVIEW

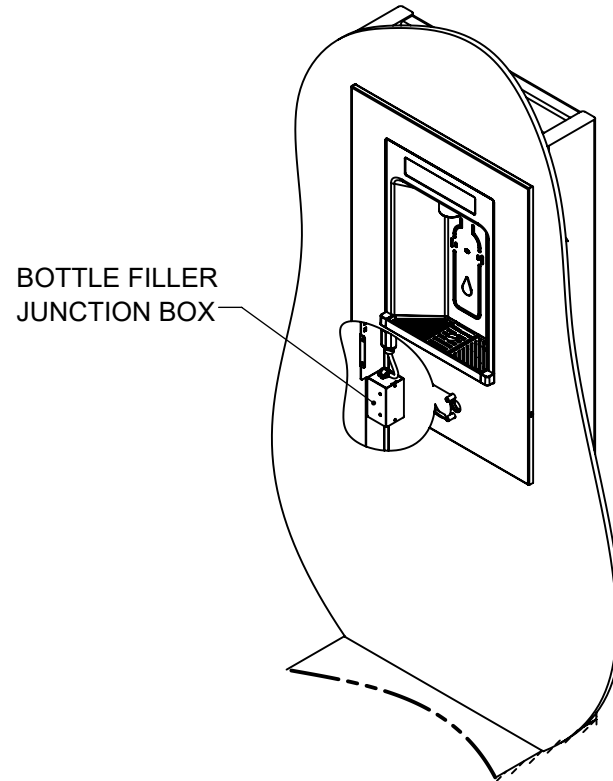

1455 KLEPPE LANE
 SPARKS, NEVADA 89431
 (775) 359-4712 FAX (775) 359-7424
 E-MAIL: HAWS@HAWSO.COM
 WEBSITE: WWW.HAWSO.COM

ECN: 6000	REV. ECN: 6000	BY: DHP	MODEL(S) 1X0XHS, SINGLE FOUNTAIN MODELS, REAR ACCESS	PART NUMBER 0510002220.D
DRAWN: DHP	DATE: 12/15/22	CHKD: DHP		REVISION 1
APPROVED: JU	DATE: 07/08/24	SCALE: 1:20	DRAWING TYPE: INSTALLATION	SIZE: A

15. MOUNT THE DRINKING FOUNTAIN TO THE PROTRUDING 3/8" STUDS FROM STEP 11. INSTALL 4X 3/8" NUTS (SUPPLIED) AND TIGHTEN FULLY (25 LB-FT).
16. INSTALL THE WASTE BEND (SUPPLIED), CUT TO LENGTH AS REQUIRED. REFER TO SHEET 3 FOR DRAIN HEIGHTS FOR EACH MODEL. SET LOWER COVER AND #8 PAN HEAD SCREWS ASIDE, THESE WILL BE INSTALLED ONCE THE WATER SUPPLY PLUMBING IS COMPLETE.

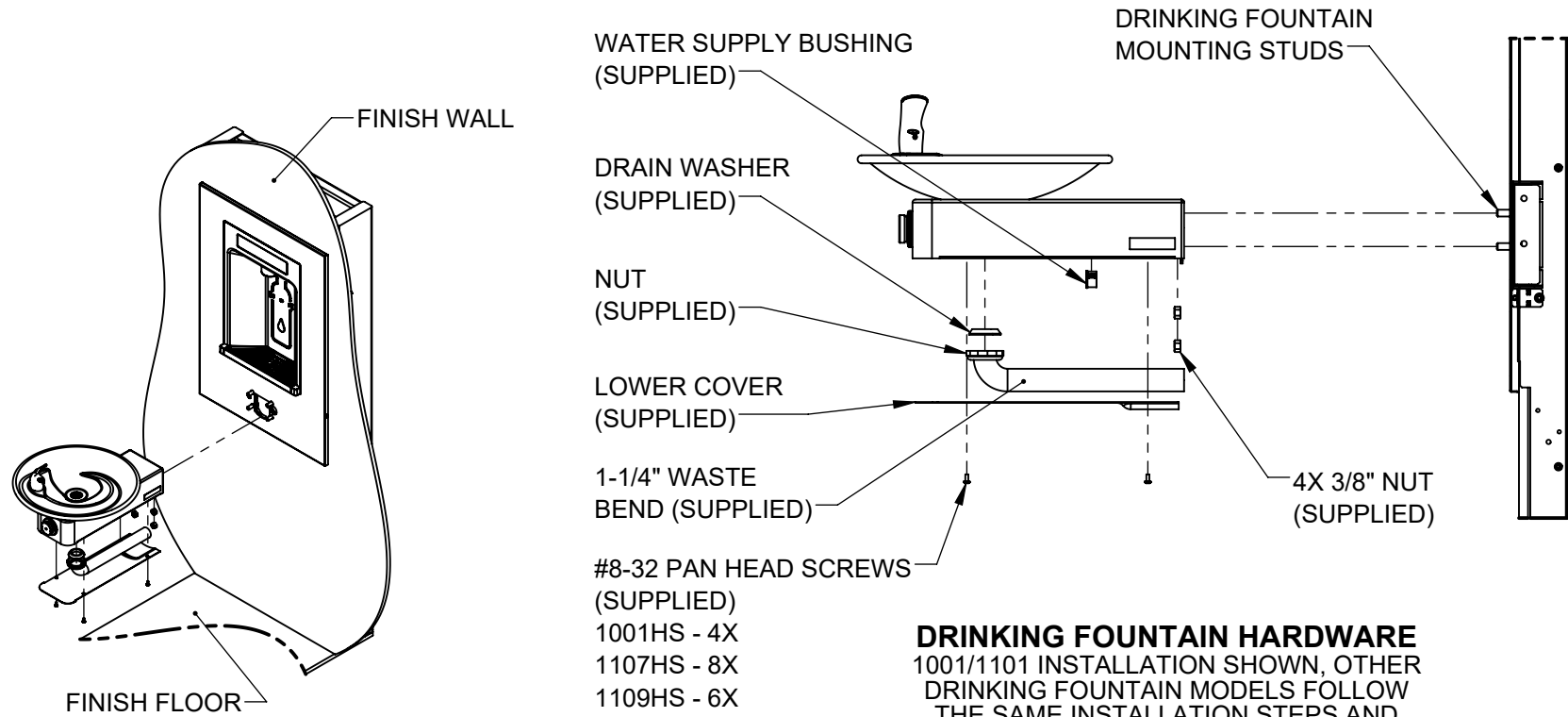

DRINKING FOUNTAIN HARDWARE
 1001/1101 INSTALLATION SHOWN, OTHER DRINKING FOUNTAIN MODELS FOLLOW THE SAME INSTALLATION STEPS AND CONTAIN SIMILAR PARTS.

- #8-32 PAN HEAD SCREWS (SUPPLIED)
 1001HS - 4X
 1107HS - 8X
 1109HS - 6X

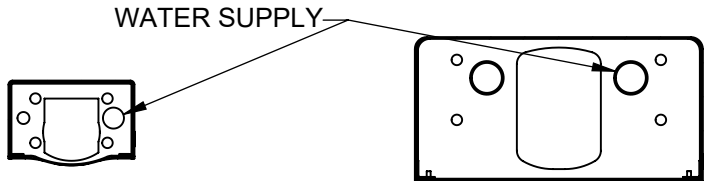

**1001/1101
 HOLE
 PATTERN**

**1107/1117 &
 1109/1119 HOLE
 PATTERN**

 Haws Since 1906		1455 KLEPPE LANE SPARKS, NEVADA 89431 (775) 359-4712 FAX (775) 359-7424 E-MAIL: HAWS@HAWSCO.COM WEBSITE: WWW.HAWSCO.COM	
		ECN: 6000 DRAWN: DHP APPROVED: JU	REV. ECN: 6000 DATE: 12/15/22 DATE: 07/08/24
PART NUMBER 0510002220.D REVISION 1			SHEET 8 OF 11

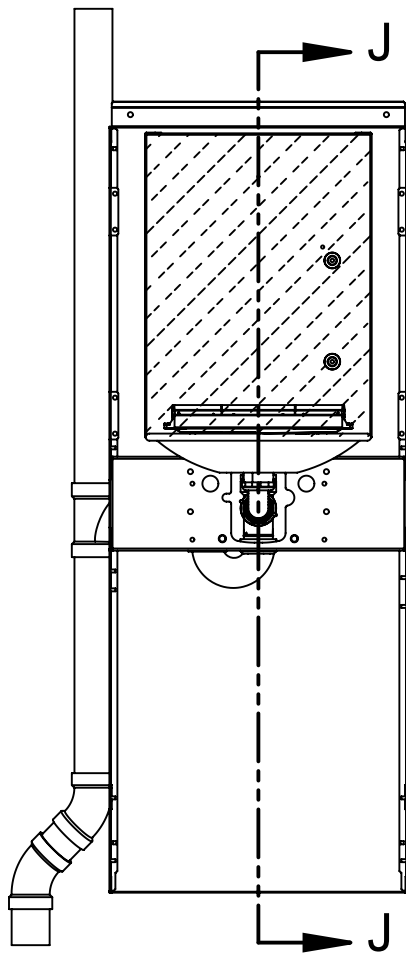

FRONT VIEW
(SOME COMPONENTS HIDDEN FOR CLARITY)

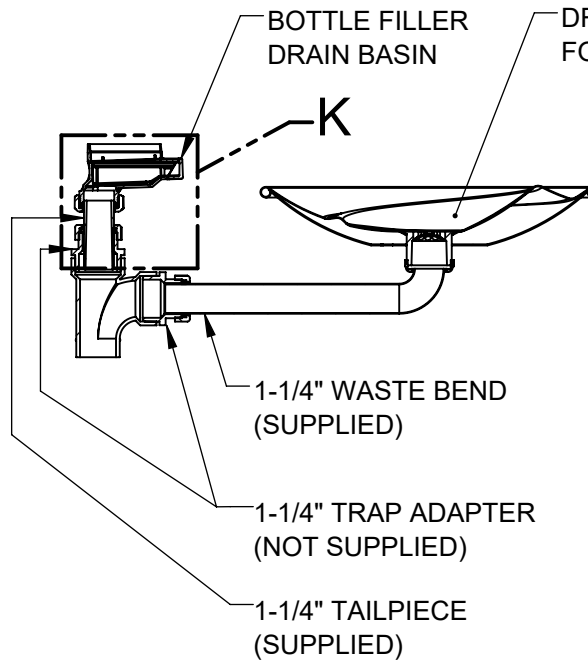

SECTION J-J
(ENLARGED)

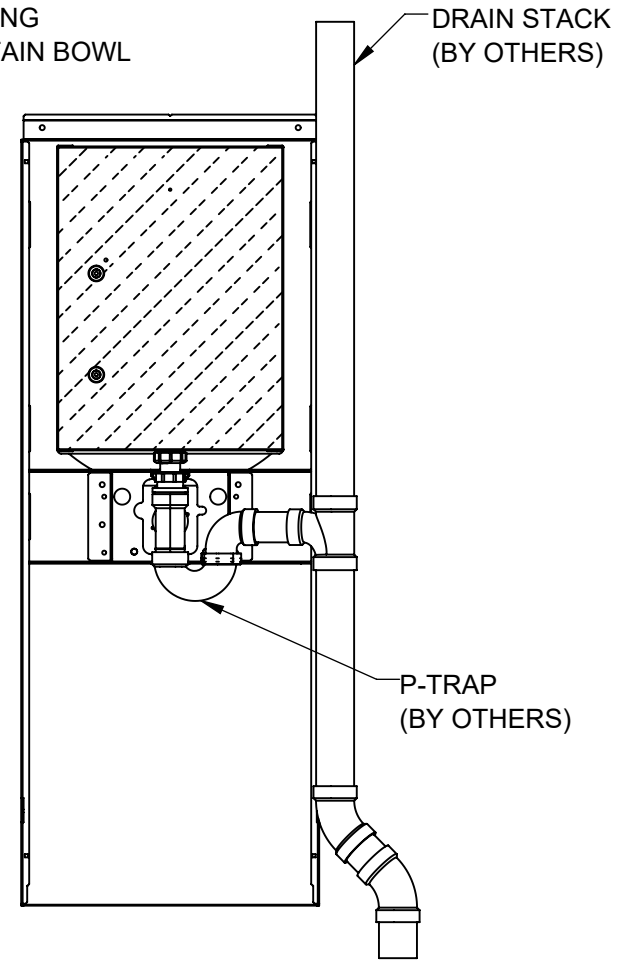

BACK VIEW
(SOME COMPONENTS HIDDEN FOR CLARITY)

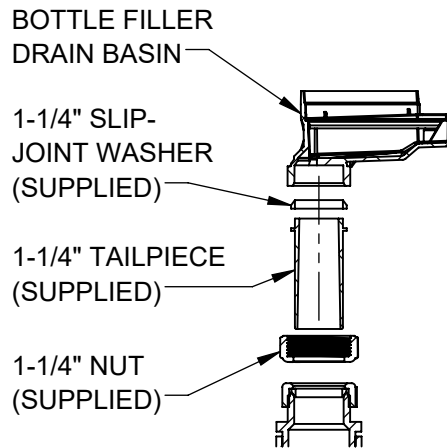

DETAIL K
(EXPLODED VIEW)

FOR REFERENCE ONLY

DRAIN STACK SHOWN AS REFERENCE ONLY. LOCAL, STATE, OR FEDERAL CODES SHOULD BE ADHERED TO FOR PROPER DRAIN INSTALLATION.

		1455 KLEPPE LANE SPARKS, NEVADA 89431 (775) 359-4712 FAX (775) 359-7424 E-MAIL: HAWS@HAWS.CO.COM WEBSITE: WWW.HAWS.CO.COM	
		ECN: 6000 DRAWN: DHP APPROVED: JU	REV. ECN: 6000 DATE: 12/15/22 DATE: 07/08/24
SCALE: 1:12 DRAWING TYPE: INSTALLATION SIZE: A		SHEET 9 OF 11	

17. INSTALL 3/8" TUBING AS SHOWN. NOTE DIRECTION OF FLOW ARROWS ON FILTER AND PRESSURE REDUCING VALVE. CUT ALL TUBING AND INSULATION AS REQUIRED, ENSURE TUBING IS CUT SQUARE AND FULLY INSERTED INTO PUSH-TO-CONNECT FITTINGS.

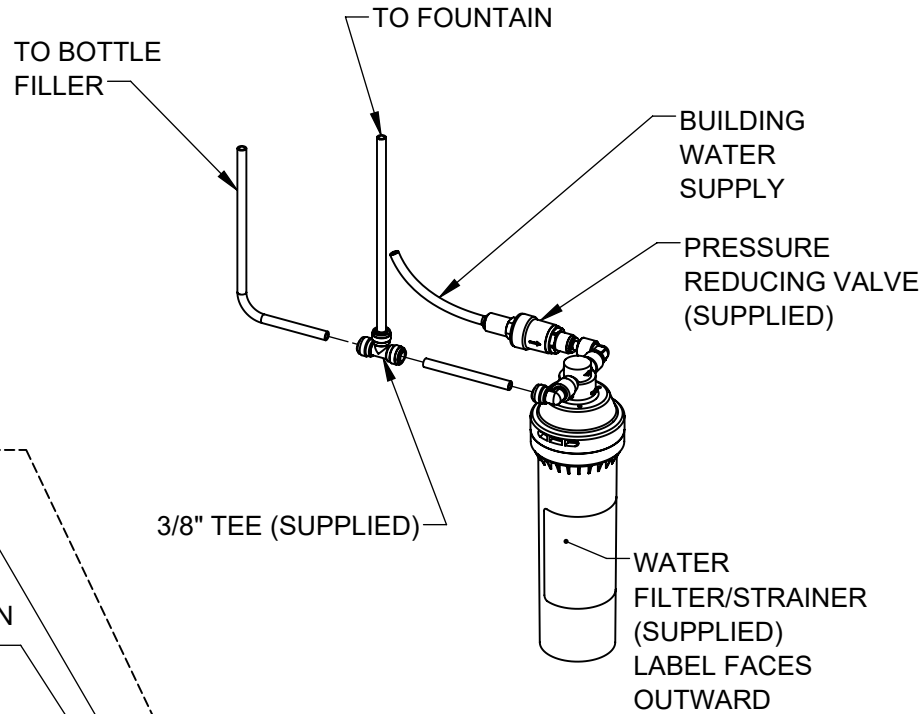

WATERWAY DIAGRAM

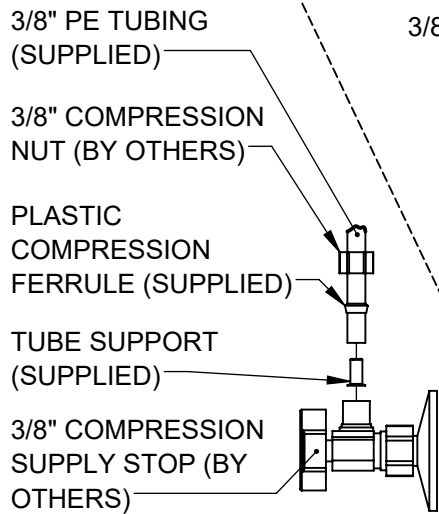

WATER SUPPLY CONNECTION

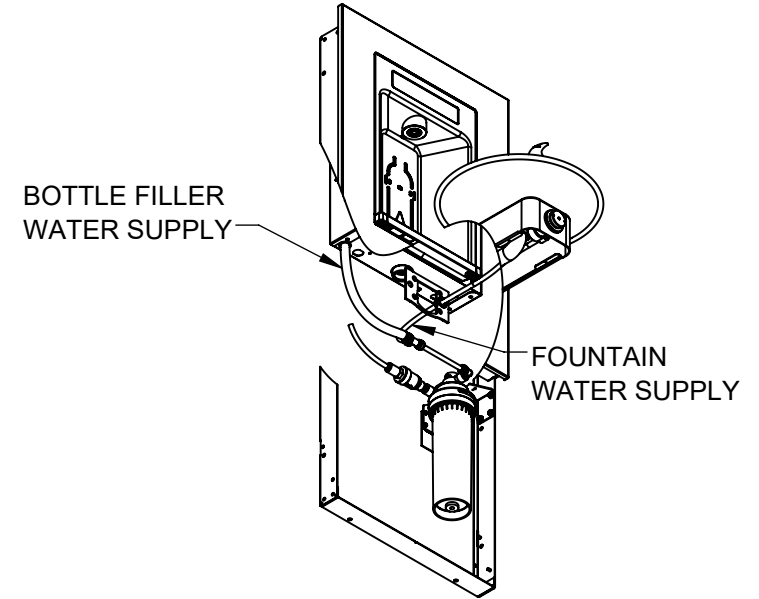

WATERWAY LAYOUT
(SOME COMPONENTS HIDDEN FOR CLARITY)

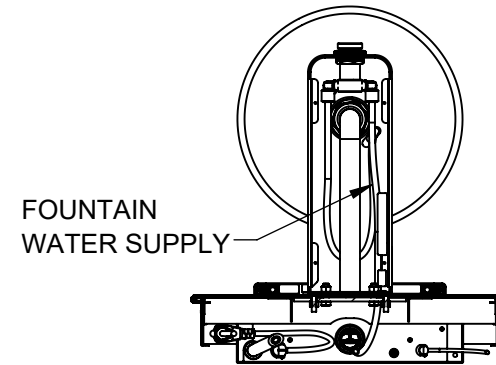

BOTTOM VIEW
(SOME COMPONENTS HIDDEN FOR CLARITY)

 Haws Since 1906		1455 KLEPPE LANE SPARKS, NEVADA 89431 (775) 359-4712 FAX (775) 359-7424 E-MAIL: HAWS@HAWS.CO.COM WEBSITE: WWW.HAWS.CO.COM	
		ECN: 6000 DRAWN: DHP APPROVED: JU	REV. ECN: 6000 DATE: 12/15/22 DATE: 07/08/24
PART NUMBER 0510002220.D			REVISION 1
SCALE: 1:16		DRAWING TYPE: INSTALLATION	SIZE: A SHEET 10 OF 11

18. CONNECT THE NEMA 5-15P BOTTLE FILLER PLUG TO THE NEMA 5-15R RECEPTACLE. VERIFY THAT THE BOTTLE FILLER DISPLAY HAS POWERED ON.
19. INSTALL THE FILTER CARTRIDGE INTO THE FILTER HEAD.
20. INSTALL DRINKING FOUNTAIN LOWER COVER WITH #8 PAN HEAD SCREWS (SUPPLIED).

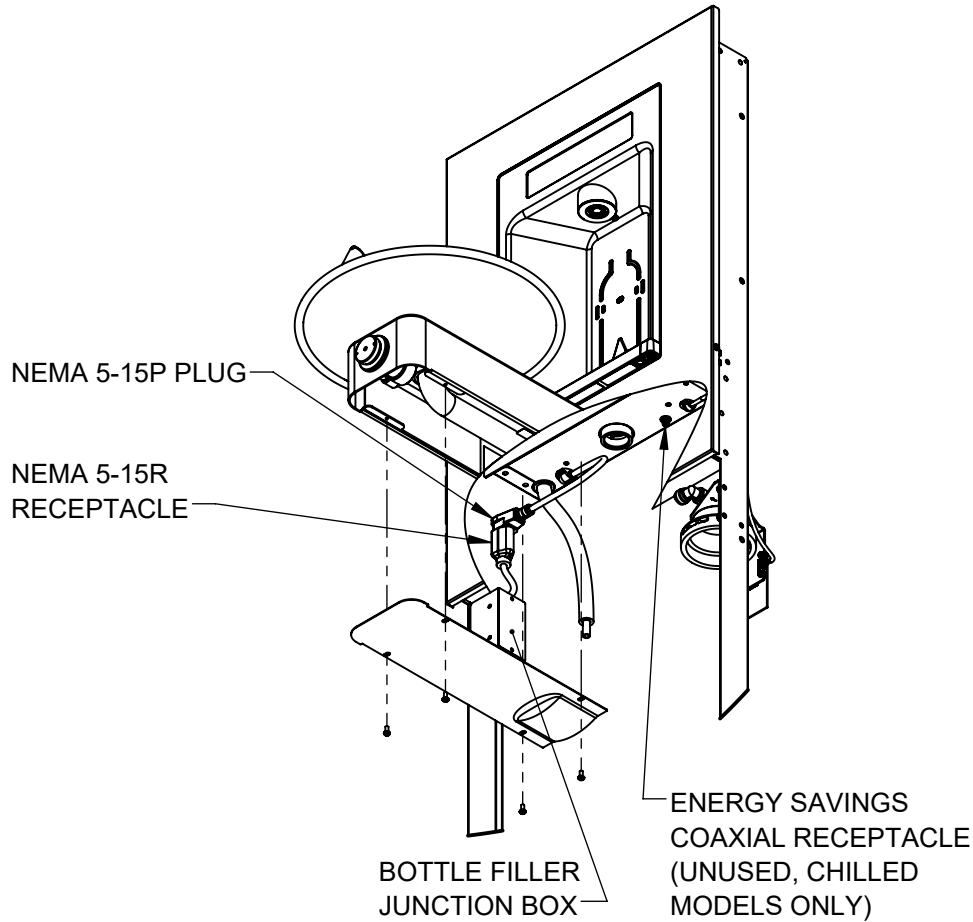

ELECTRICAL CONNECTIONS AND DRINKING FOUNTAIN LOWER COVER
(SOME COMPONENTS HIDDEN FOR CLARITY)

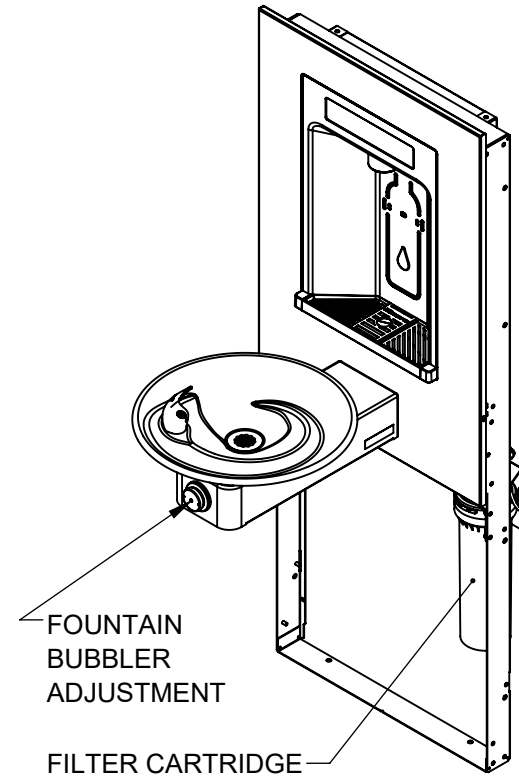

FILTER INSTALL & BUBBLER ADJUSTMENT

 Haws Since 1906		1455 KLEPPE LANE SPARKS, NEVADA 89431 (775) 359-4712 FAX (775) 359-7424 E-MAIL: HAWS@HAWS.CO.COM WEBSITE: WWW.HAWS.CO.COM	
		ECN: 6000 REV. ECN: 6000 DRAWN: DHP APPROVED: JU	BY: DHP DATE: 12/15/22 DATE: 07/08/24
SCALE: 1:12		DRAWING TYPE: INSTALLATION	
SIZE: A		SHEET 11 OF 11	