

FEATURES & BENEFITS

FIELD CONFIGURABLE FILTERING

3000 gallon (11356 L) capacity, Electronic Lifecycle Control filter cartridge. Choose between filtered or non-filtered water with the included interchangeable 3000-gallon filter and 5y rated strainer.

AUTO PURGE

Auto purge feature automatically cycles once every 24 hours, if no use, to assure a fresh water supply as well as trap integrity.

VANDAL RESISTANT

The bubbler head, push button, round bowl, drain strainer and bottom plate are locked in place, and the sensor resists scratching and water droplet fowling and features a timeout function discouraging unwanted vandal tampering.

LED DISPLAY

Display menu which shows sensor range adjustment, factory reset, software/firmware version readout and error readout, along with bottle counter showing number of bottles saved.

MOUNTING

Heavy-duty 16-gauge galvanized steel mounting frame provides a secure and quick installation, and allows enough access room for water stop, electrical junction box, filter and drain connections.

DRINKING FOUNTAIN VALVE

The push-button activated valve offers the only all stainless steel valve body that is machined out of solid bar stock, is fully serviceable through the front of the push button assembly offering access to the water control cartridge and integral water supply strainer, and with front access to the water stream height adjustment for easy maintenance without having to remove the valve.

OPTIONS

- Filter Replacement: Model 6428-C pack of twelve 3000-gallon (11356 L) replacement filters.
- Copper Button: Model PBA6C, flanged push button assembly with antimicrobial copper button for the 5874PBF valve.

For more information, visit www.hawsco.com or call (888) 640-4297.



SPECIFICATIONS

Model 1001HS RIVIVE™ Hydration Station™ vandal-resistant wall-mounted ADA drinking fountain and recessed motion-activated bottle filler features an 18-gauge Type 304 Stainless Steel satin finish basin with integral swirl design, 14-gauge Type 304 Stainless Steel wall bracket, 100% lead-free waterways, vandal-resistant push-button operated stainless steel valve with front-accessible cartridge and flow adjustment, polished chrome-plated brass vandal-resistant bubbler head with integral laminar anti-squirt flow, chrome-plated brass vandal-resistant waste strainer, vandal-resistant bottom plate, stainless steel satin finish back panel, and 1-1/4" (3.2 cm) O.D. waste pipe. Bottle filler includes a 3000 gallon (11356 L) capacity, Electronic Lifecycle Control filter cartridge, with filter replacement indicator light, LED lighted 12" sensor operated bottle opening with quick 1.1 gpm fill rate and laminar flow, auto purge feature automatically cycles water once every 24 hours, display menu which shows sensor range adjustment, factory reset, software/firmware version readout and error readout, along with bottle counter showing number of bottles saved, and vandal-resistant sensor resists scratching and water droplet fowling. (Filter, P-trap and stop require rear access)

APPLICATIONS

Specifically, this type fountain with bottle filler may be placed in settings such as: schools, office buildings, shopping malls, and other indoor environments where there is a demand for a water source and/or wheelchair access. Model meets all current Federal Regulations for the disabled including those in the Americans with Disabilities Act. Haws manufactures drinking fountains, faucets and electric water coolers to be lead-free by all known definitions including NSF/ANSI/CAN 61-Section 9, NSF/ANSI/CAN 372, California Proposition 65, and the Federal Safe Drinking Water Act. Product is compliant to California Health and Safety Code 116875 (AB 1953-2006), and 116876 (AB 100) "NSF/ANSI/CAN 61: Q ≤ 1".



NOTES:

- ACCESS TO THE BACK SIDE OF THE WALL IS REQUIRED TO INSTALL AND MAINTAIN 1X0XH5 MODELS. THESE MODELS ARE SUITABLE FOR WALLS WITH DRYWALL (5/8" MAX) SHEATHING ONLY.
- HOLD ROUGH-IN DIMENSIONS $\pm 1/4"$ (6.4mm).
- WHEN INSTALLING THIS UNIT, LOCAL, STATE, OR FEDERAL CODES SHOULD BE ADHERED TO. FOR CHILD-HEIGHT INSTALLATIONS ON 1107 MODELS, REDUCE DIMENSIONS MARKED (*) BY 3" [76mm]. INSTALL A TRAP IN THE WASTE LINE AND A SCREWDRIVER STOP IN THE SUPPLY LINE IF REQUIRED.

	A	B	
FOUNTAIN MODELS	BUBBLER HEIGHT	DRAIN HEIGHT	WASTE BEND SIZE
1001/1011	33 13/16" [858mm]	28" [711mm]	1-1/4"
1107/1117	*32 13/16" [834mm]	*27 5/16" [694mm]	1-1/4"
1109/1119	34 7/16" [875mm]	28 1/4" [718mm]	1-1/4"

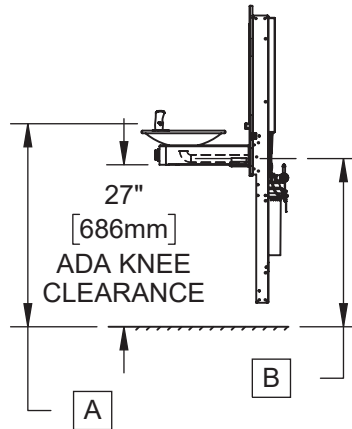
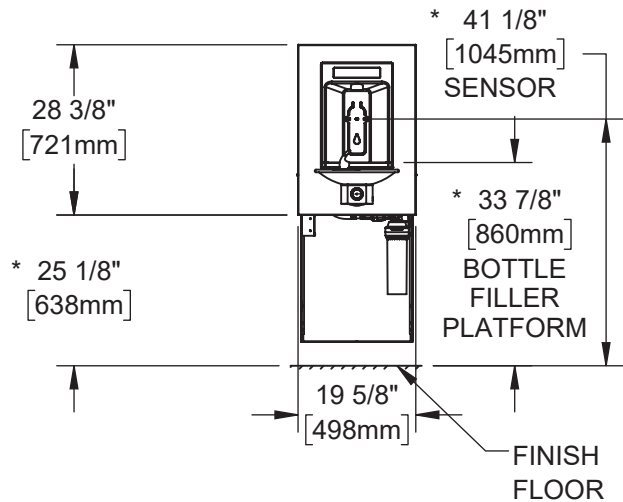
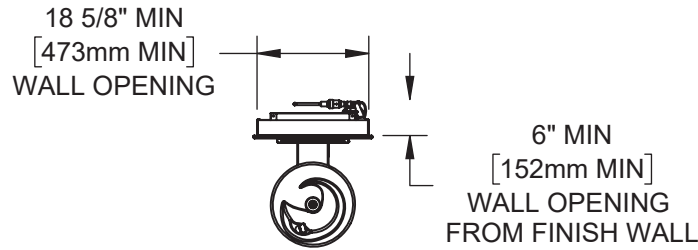

1001HS

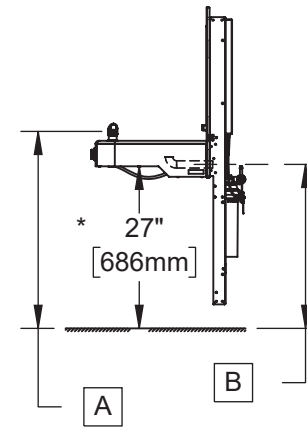

1107HS

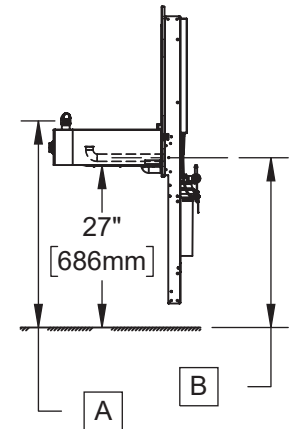

1109HS

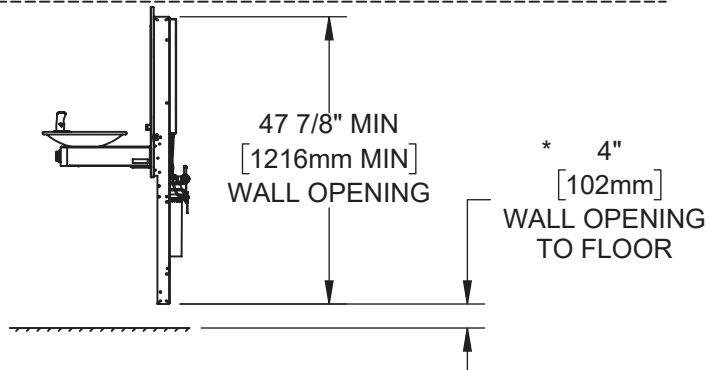



Haws[®]

Since 1906

1455 KLEPPE LANE
SPARKS, NEVADA 89431
(775) 359-4712 FAX (775) 359-7424
E-MAIL: HAWS@HAWS.CO.COM
WEBSITE: WWW.HAWS.CO.COM

ECN: 6000	REV. ECN: 6000	BY: DHP	MODEL(S): 1X0XH5, SINGLE FOUNTAIN MODELS, REAR ACCESS	PART NUMBER: 0510002220.D
DRAWN: DHP	DATE: 12/15/22	CHKD: DHP		REVISION: 1
APPROVED: JU	DATE: 07/08/24	SCALE: 1:32	DRAWING TYPE: INSTALLATION	SIZE: A SHEET 1 OF 11

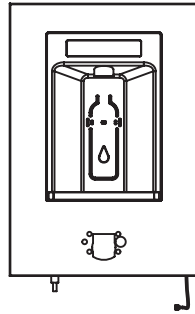

BOTTLE FILLER
(HS3 SHOWN FOR REFERENCE)

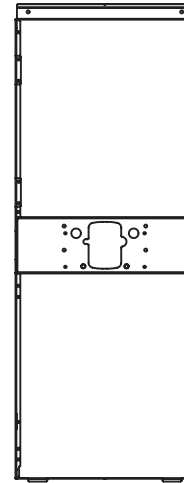

FRAME (HS11)



1001 FOUNTAIN (HS7)

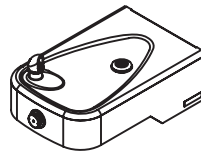

1107 FOUNTAIN (HS8)

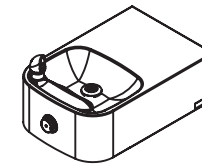

1109 FOUNTAIN (HS9)

HS MODEL #	BOTTLE FILLER	FRAME	FOUNTAIN	LOOSE PARTS KIT
1001HS	HS3	HS11	HS7	HS105
1107HS	HS5	HS11	HS8	HS105
1109HS	HS5	HS11	HS9	HS105



1455 KLEPPE LANE
SPARKS, NEVADA 89431
(775) 359-4712 FAX (775) 359-7424
E-MAIL: HAWS@HAWSO.COM
WEBSITE: WWW.HAWSO.COM

ECN: 6000	REV. ECN: 6000	BY: DHP	MODEL(S) 1X0XHS, SINGLE FOUNTAIN MODELS, REAR ACCESS	PART NUMBER 0510002220.D
DRAWN: DHP	DATE: 12/15/22	CHKD: DHP		REVISION 1
APPROVED: JU	DATE: 07/08/24	SCALE: 1:20	DRAWING TYPE: INSTALLATION	SIZE: A SHEET 2 OF 11

4. ROUGH IN WALL CAVITY WITH DIMENSIONS SHOWN. ROUGH IN ELECTRICAL, WASTE PIPING, AND WATER SUPPLY AS REQUIRED

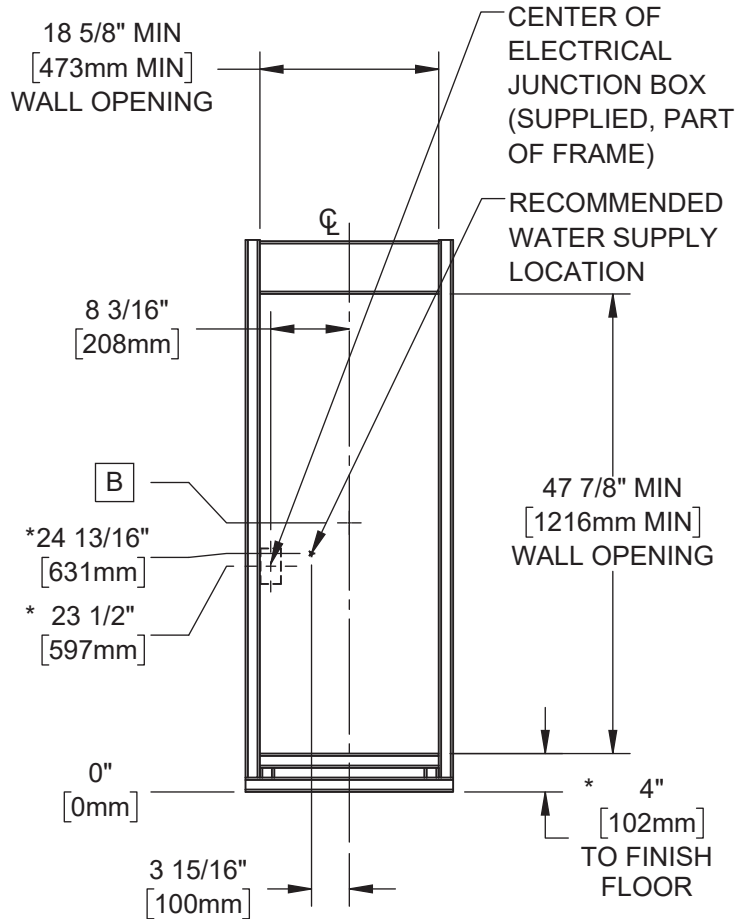

TYPICAL WALL OPENING

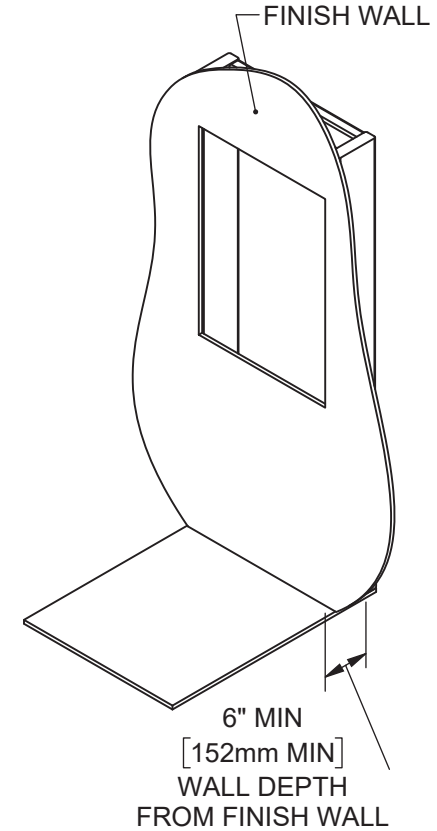

	B	
FOUNTAIN MODELS	LOW SIDE DRAIN	WASTE BEND SIZE
1001/1011	28" [711mm]	1-1/4"
1107/1117	*27 5/16" [694mm]	1-1/4"
1109/1119	28 1/4" [718mm]	1-1/4"



Haws[®]

Since 1906

1455 KLEPPE LANE
SPARKS, NEVADA 89431
(775) 359-4712 FAX (775) 359-7424
E-MAIL: HAWS@HAWSO.COM
WEBSITE: WWW.HAWSO.COM

ECN: 6000	REV. ECN: 6000	BY: DHP	MODEL(S) 1X0XH8, SINGLE FOUNTAIN MODELS, REAR ACCESS	PART NUMBER 0510002220.D
DRAWN: DHP	DATE: 12/15/22	CHKD: DHP		REVISION 1
APPROVED: JU	DATE: 07/08/24	SCALE: 1:20	DRAWING TYPE: INSTALLATION	SIZE: A SHEET 3 OF 11

5. REMOVE 2X DRYWALL TABS FROM THE BOTTOM OF THE FRAMES BY BENDING ALONG PERFORATIONS (DETAIL A).
6. MOUNT FRAME ASSEMBLY INTO WALL CAVITY FROM THE BACK SIDE OF THE FINISH WALL USING 12X STRUCTURAL SCREWS (NOT SUPPLIED), USE SHIMS AS NEEDED AND ENSURE THE FRAME IS SQUARE.
7. INSTALL THE 2X PANEL CLIPS USING #10 NUTS (SUPPLIED) AS SHOWN (DETAIL B).

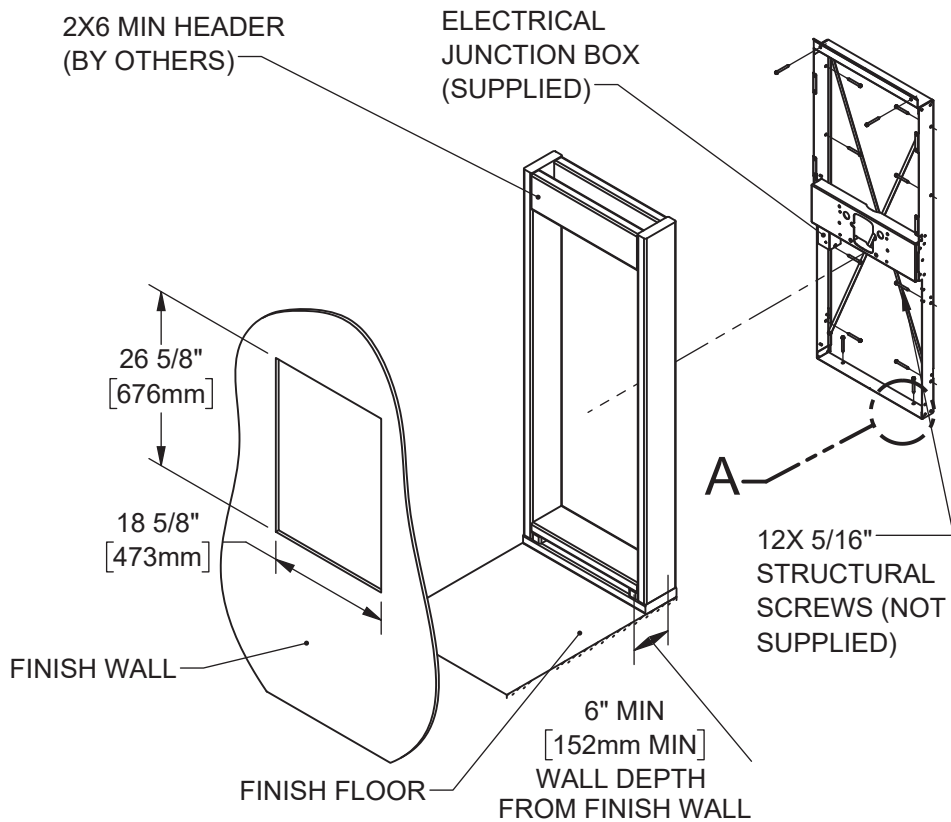

FRAME INSTALLATION

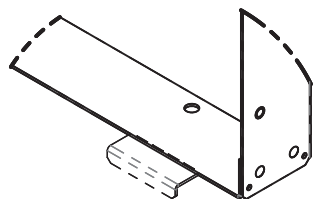

**DETAIL A
DRYWALL TAB REMOVAL
(4 PLACES)**

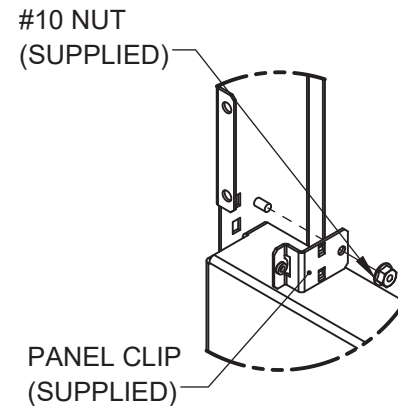
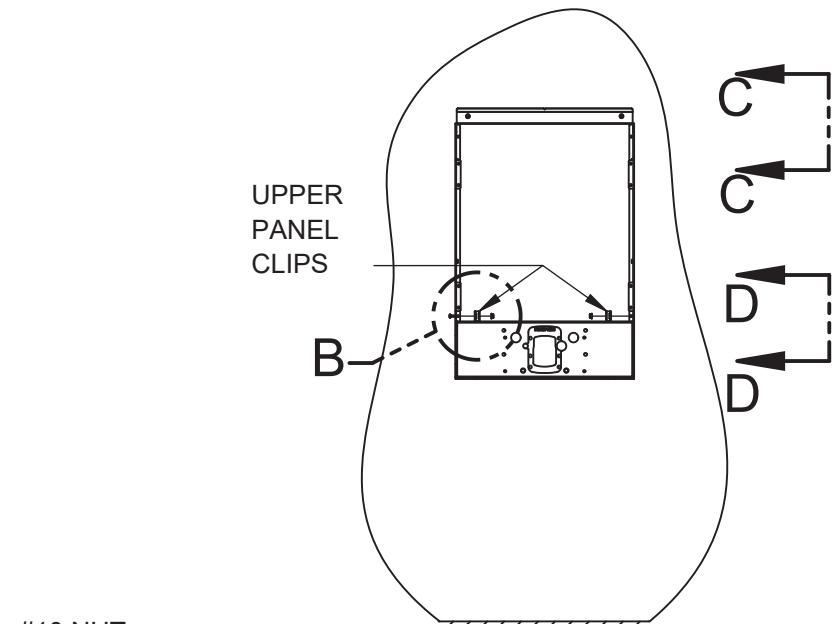

**DETAIL B
PANEL CLIP
INSTALL
(2 PLACES)**

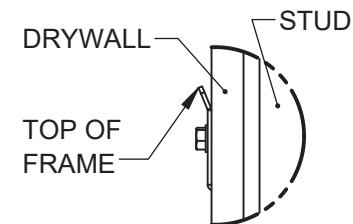

**VIEW ON C-C
(ENLARGED)**

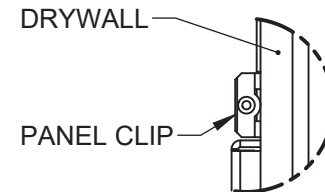

**VIEW ON D-D
(ENLARGED)**



1455 KLEPPE LANE
SPARKS, NEVADA 89431
(775) 359-4712 FAX (775) 359-7424
E-MAIL: HAWS@HAWSO.COM
WEBSITE: WWW.HAWSO.COM

ECN: 6000	REV. ECN: 6000	BY: DHP	MODEL(S) 1X0XHS, SINGLE FOUNTAIN MODELS, REAR ACCESS	PART NUMBER 0510002220.D
DRAWN: DHP	DATE: 12/15/22	CHKD: DHP		REVISION 1
APPROVED: JU	DATE: 07/08/24	SCALE: 1:20	DRAWING TYPE: INSTALLATION	SIZE: A

8. REMOVE SHIPPING BRACKETS FROM FRAME (DETAIL E).
9. INSTALL FILTER HEAD USING 3X SUPPLIED #10 NUTS (DETAIL F).
10. (1001HS ONLY) INSTALL 1001 DRINKING FOUNTAIN ADAPTERS USING 2X SUPPLIED 3/8" NUTS (DETAIL G).

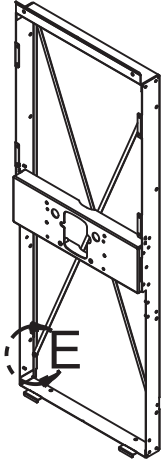

REMOVE SHIPPING
CROSS BRACING

DETAIL E
(4 PLACES)

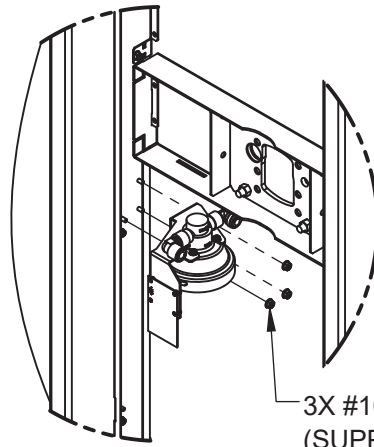

DETAIL F
FILTER/STRAINER HEAD INSTALL
(ALL MODELS)

3X #10 NUT
(SUPPLIED)

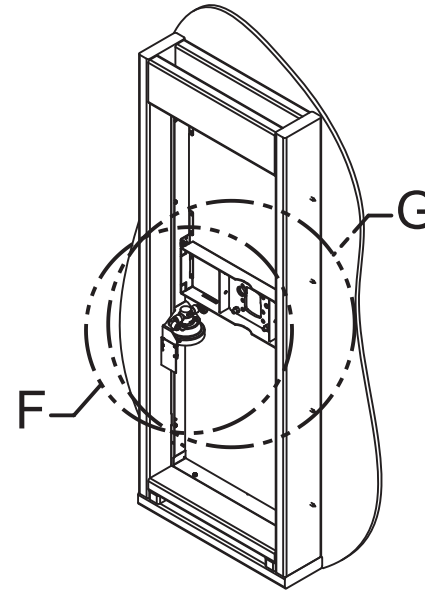

REAR VIEW

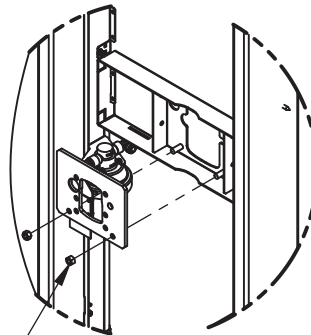

DETAIL G
1001 FOUNTAIN ADAPTER PLATE (1001/1011
MODELS ONLY)

2X 3/8" NUT
(SUPPLIED)



1455 KLEPPE LANE
SPARKS, NEVADA 89431
(775) 359-4712 FAX (775) 359-7424
E-MAIL: HAWS@HAWSO.COM
WEBSITE: WWW.HAWSO.COM

ECN: 6000	REV. ECN: 6000	BY: DHP	MODEL(S) 1X0XHS, SINGLE FOUNTAIN MODELS, REAR ACCESS	PART NUMBER 0510002220.D
DRAWN: DHP	DATE: 12/15/22	CHKD: DHP		REVISION 1
APPROVED: JU	DATE: 07/08/24	SCALE: 1:20	DRAWING TYPE: INSTALLATION	SIZE: A
				SHEET 5 OF 11

11. INSTALL 4X 3/8" DRINKING FOUNTAIN BOLTS (SUPPLIED) FROM THE BACK SIDE OF THE FRAME.
12. HANG THE BOTTLE FILLER FROM THE TOP OF THE FRAME AND ALIGN THE PANEL SO THE 3/8" DRINKING FOUNTAIN BOLTS PROTRUDE THROUGH THE PANEL. INSTALL THE 2X #8 PANEL SCREWS (SUPPLIED) ON EITHER SIDE OF THE BOTTLE FILLER PANEL.
13. CONNECT THE FILTER CABLE (RIGHT SIDE OF THE BOTTLE FILLER) TO THE FILTER TRACKING BOARD.

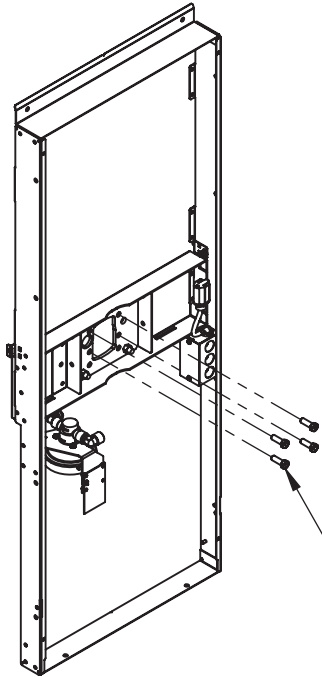

4X DRINKING FOUNTAIN BOLTS (SUPPLIED). USE WASHERS (SUPPLIED) UNDER HEAD OF BOLTS FOR 1107/1117 AND 1109/1119 MODELS

REAR VIEW

2X #8-32 BUTTON HEAD PANEL SCREWS (SUPPLIED)

FILTER CABLE

HANG BOTTLE FILLER FROM TOP OF FRAME

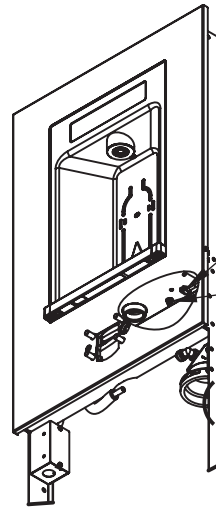
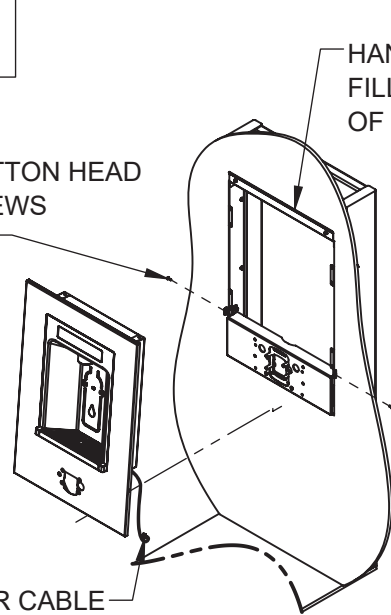

FILTER CABLE
ENERGY SAVINGS COAXIAL RECEPTACLE (UNUSED, CHILLED MODELS ONLY)

H

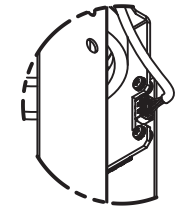
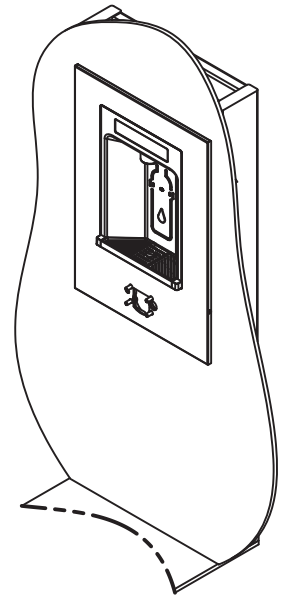

DETAIL H
FILTER TRACKING ELECTRICAL CONNECTION



1455 KLEPPE LANE
SPARKS, NEVADA 89431
(775) 359-4712 FAX (775) 359-7424
E-MAIL: HAWS@HAWSO.COM
WEBSITE: WWW.HAWSO.COM

ECN: 6000	REV. ECN: 6000	BY: DHP	MODEL(S) 1X0XH5, SINGLE FOUNTAIN MODELS, REAR ACCESS	PART NUMBER 0510002220.D
DRAWN: DHP	DATE: 12/15/22	CHKD: DHP		REVISION 1
APPROVED: JU	DATE: 07/08/24	SCALE: 1:14	DRAWING TYPE: INSTALLATION	SIZE: A
				SHEET 6 OF 11

NOTE: STEP 14 CAN BE PERFORMED LATER IN INSTALLATION IF DESIRED.

- HAVE AN ELECTRICIAN CONNECT A 120VAC/60HZ 15-AMP GFCI-PROTECTED CIRCUIT TO THE RESPECTIVE LINE, NEUTRAL, AND GROUND CONNECTIONS INSIDE THE BOTTLE FILLER JUNCTION BOX VIA ONE OF THE AVAILABLE 1/2" KNOCKOUTS.

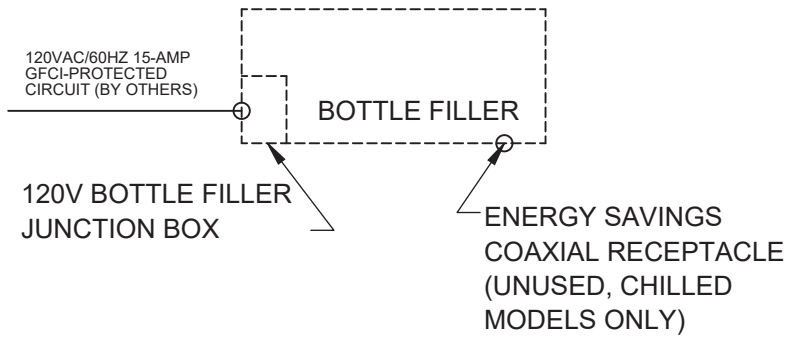

ELECTRICAL WIRING OVERVIEW

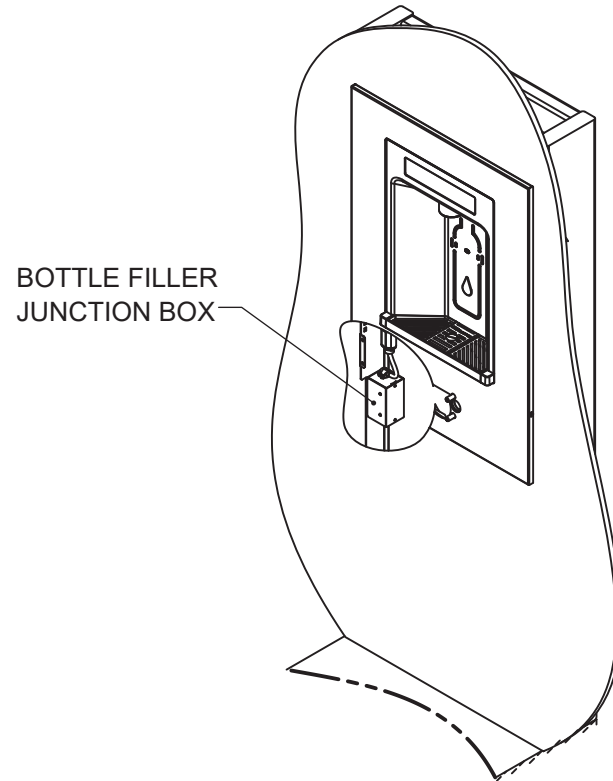

 Haws Since 1906		1455 KLEPPE LANE SPARKS, NEVADA 89431 (775) 359-4712 FAX (775) 359-7424 E-MAIL: HAWS@HAWSCO.COM WEBSITE: WWW.HAWSCO.COM			
		ECN: 6000 REV. ECN: 6000 BY: DHP DRAWN: DHP APPROVED: JU	DATE: 12/15/22 CHKD: DHP DATE: 07/08/24	MODEL(S) 1X0XHS, SINGLE FOUNTAIN MODELS, REAR ACCESS	PART NUMBER 0510002220.D REVISION 1
SCALE: 1:20		DRAWING TYPE: INSTALLATION		SIZE: A	SHEET 7 OF 11

15. MOUNT THE DRINKING FOUNTAIN TO THE PROTRUDING 3/8" STUDS FROM STEP 11. INSTALL 4X 3/8" NUTS (SUPPLIED) AND TIGHTEN FULLY (25 LB-FT).
16. INSTALL THE WASTE BEND (SUPPLIED), CUT TO LENGTH AS REQUIRED. REFER TO SHEET 3 FOR DRAIN HEIGHTS FOR EACH MODEL. SET LOWER COVER AND #8 PAN HEAD SCREWS ASIDE, THESE WILL BE INSTALLED ONCE THE WATER SUPPLY PLUMBING IS COMPLETE.

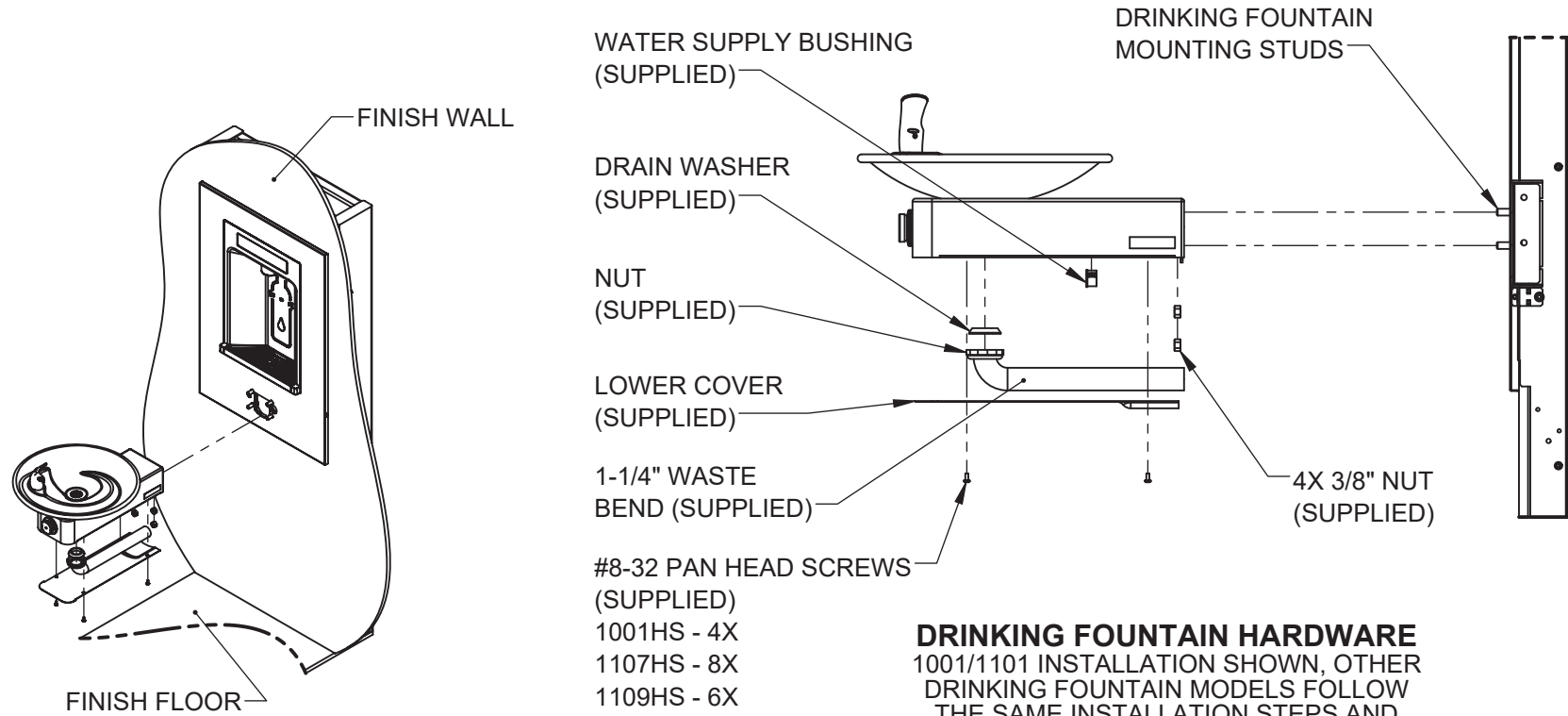

DRINKING FOUNTAIN HARDWARE
 1001/1101 INSTALLATION SHOWN, OTHER DRINKING FOUNTAIN MODELS FOLLOW THE SAME INSTALLATION STEPS AND CONTAIN SIMILAR PARTS.

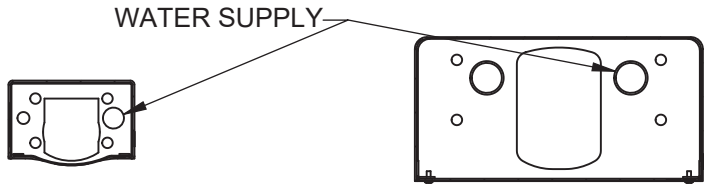

**1001/1101
HOLE
PATTERN**

**1107/1117 &
1109/1119 HOLE
PATTERN**

		1455 KLEPPE LANE SPARKS, NEVADA 89431 (775) 359-4712 FAX (775) 359-7424 E-MAIL: HAWS@HAWSO.COM WEBSITE: WWW.HAWSO.COM	
		ECN: 6000 DRAWN: DHP APPROVED: JU	REV. ECN: 6000 DATE: 12/15/22 DATE: 07/08/24
PART NUMBER 0510002220.D REVISION 1			SHEET 8 OF 11

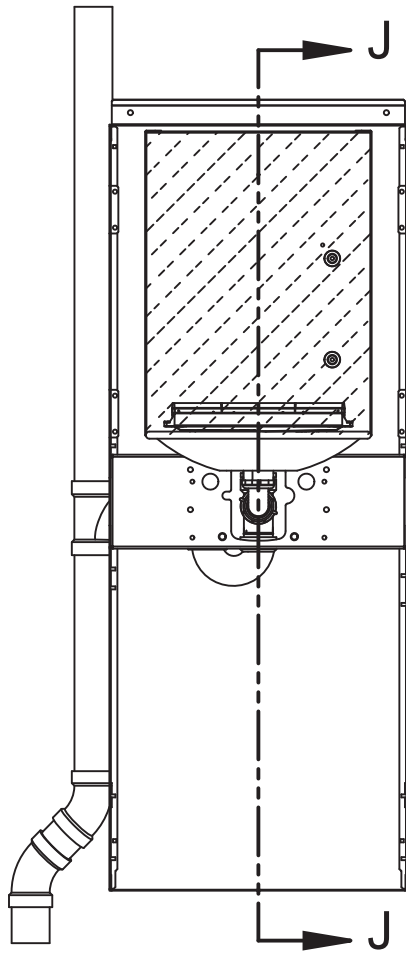

FRONT VIEW
(SOME COMPONENTS HIDDEN FOR CLARITY)

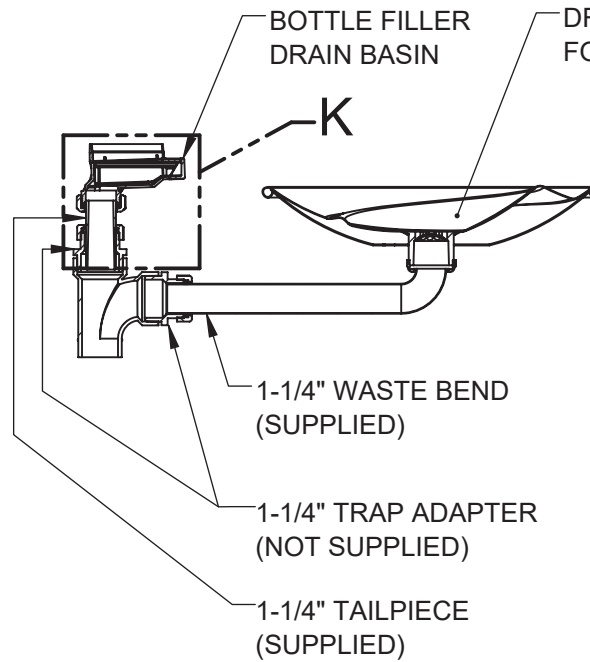

SECTION J-J
(ENLARGED)

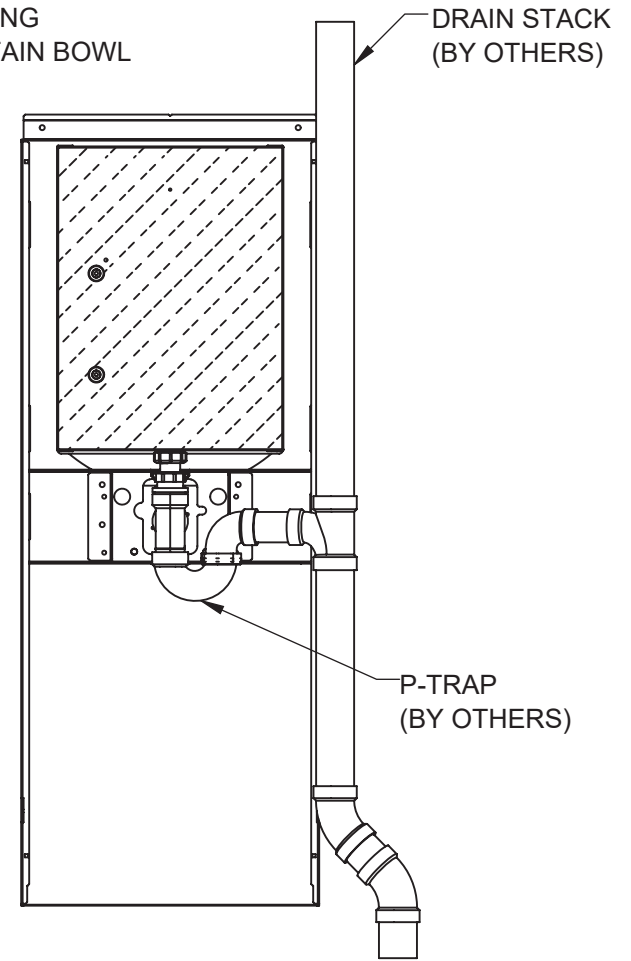

BACK VIEW
(SOME COMPONENTS HIDDEN FOR CLARITY)

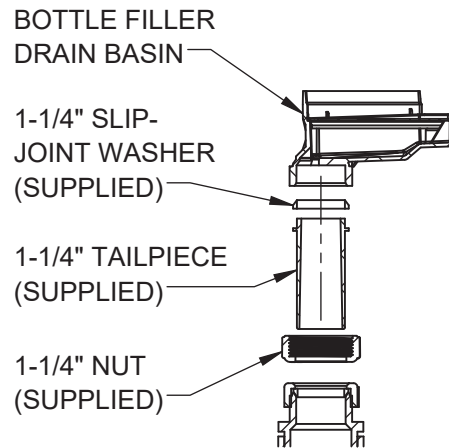

DETAIL K
(EXPLODED VIEW)

FOR REFERENCE ONLY

DRAIN STACK SHOWN AS REFERENCE ONLY. LOCAL, STATE, OR FEDERAL CODES SHOULD BE ADHERED TO FOR PROPER DRAIN INSTALLATION.

		1455 KLEPPE LANE SPARKS, NEVADA 89431 (775) 359-4712 FAX (775) 359-7424 E-MAIL: HAWS@HAWS.CO.COM WEBSITE: WWW.HAWS.CO.COM	
		ECN: 6000 DRAWN: DHP APPROVED: JU	REV. ECN: 6000 DATE: 12/15/22 DATE: 07/08/24
SCALE: 1:12		DRAWING TYPE: INSTALLATION	
SIZE: A		SHEET 9 OF 11	

17. INSTALL 3/8" TUBING AS SHOWN. NOTE DIRECTION OF FLOW ARROWS ON FILTER AND PRESSURE REDUCING VALVE. CUT ALL TUBING AND INSULATION AS REQUIRED, ENSURE TUBING IS CUT SQUARE AND FULLY INSERTED INTO PUSH-TO-CONNECT FITTINGS.

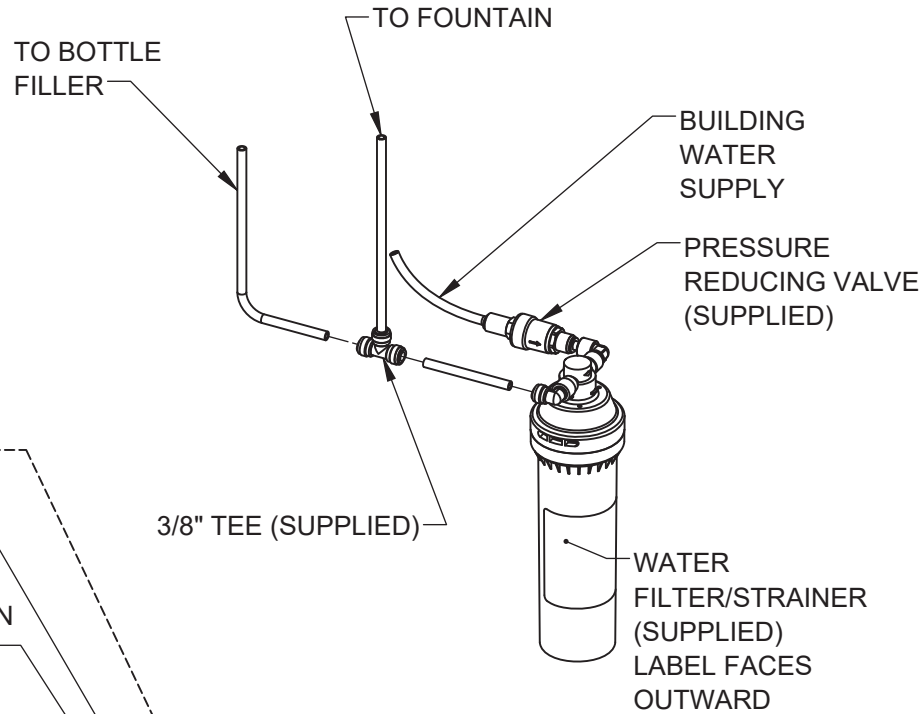

WATERWAY DIAGRAM

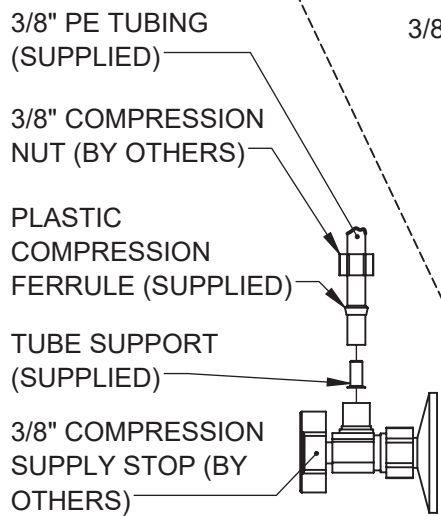

WATER SUPPLY CONNECTION

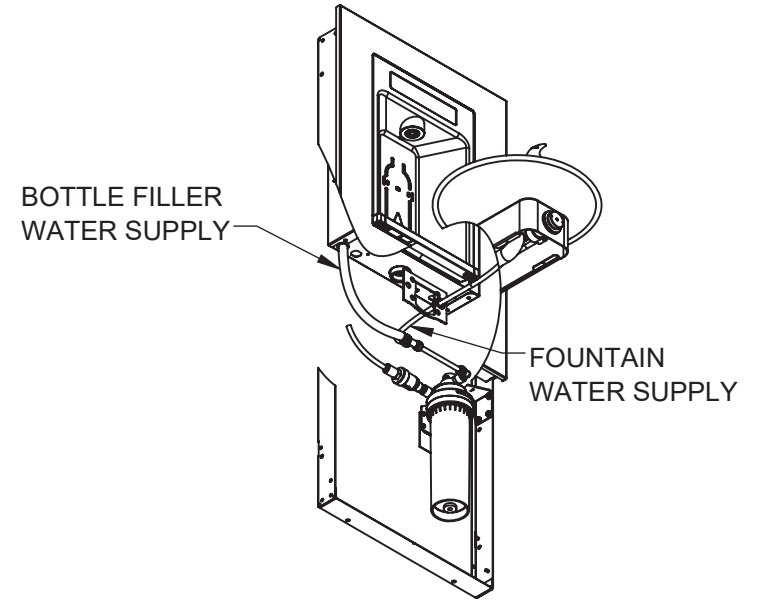

WATERWAY LAYOUT
(SOME COMPONENTS HIDDEN FOR CLARITY)

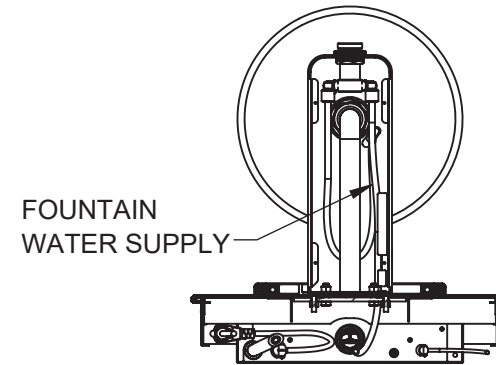

BOTTOM VIEW
(SOME COMPONENTS HIDDEN FOR CLARITY)

 Haws Since 1906		1455 KLEPPE LANE SPARKS, NEVADA 89431 (775) 359-4712 FAX (775) 359-7424 E-MAIL: HAWS@HAWS.CO.COM WEBSITE: WWW.HAWS.CO.COM	
		ECN: 6000 DRAWN: DHP APPROVED: JU	REV. ECN: 6000 DATE: 12/15/22 DATE: 07/08/24
PART NUMBER 0510002220.D			REVISION 1
SCALE: 1:16		DRAWING TYPE: INSTALLATION	SIZE: A SHEET 10 OF 11

18. CONNECT THE NEMA 5-15P BOTTLE FILLER PLUG TO THE NEMA 5-15R RECEPTACLE. VERIFY THAT THE BOTTLE FILLER DISPLAY HAS POWERED ON.
19. INSTALL THE FILTER CARTRIDGE INTO THE FILTER HEAD.
20. INSTALL DRINKING FOUNTAIN LOWER COVER WITH #8 PAN HEAD SCREWS (SUPPLIED).

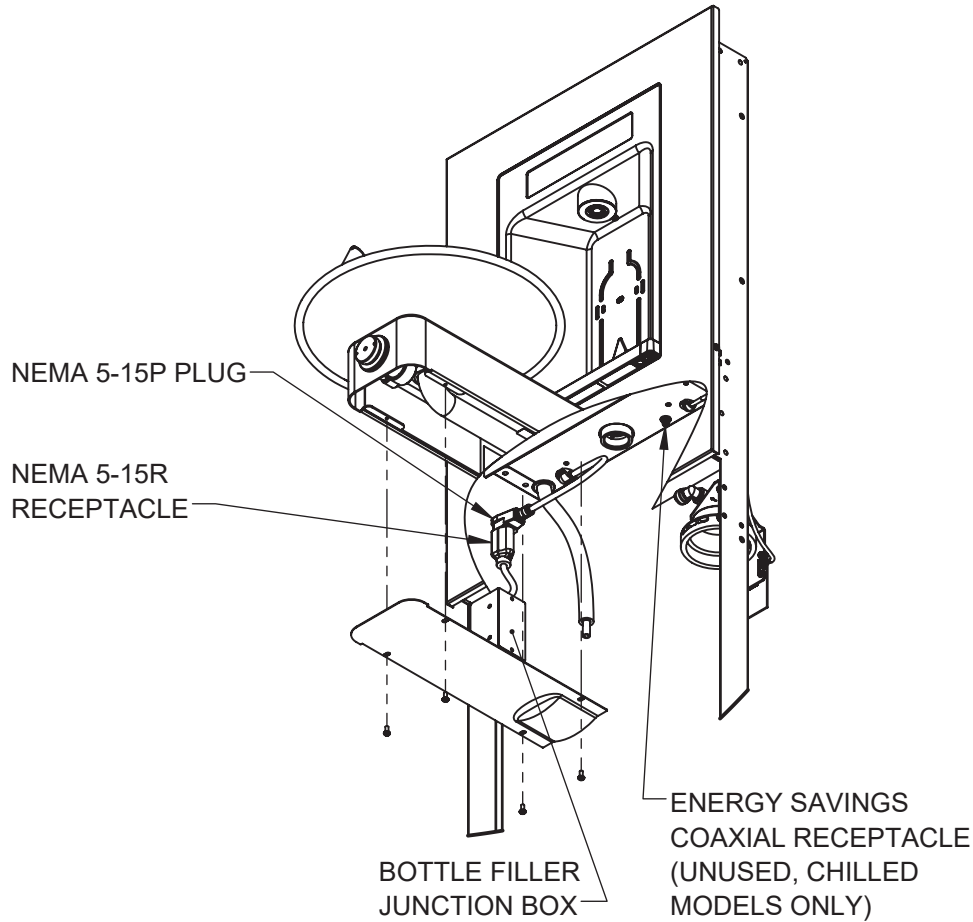

ELECTRICAL CONNECTIONS AND DRINKING FOUNTAIN LOWER COVER
(SOME COMPONENTS HIDDEN FOR CLARITY)

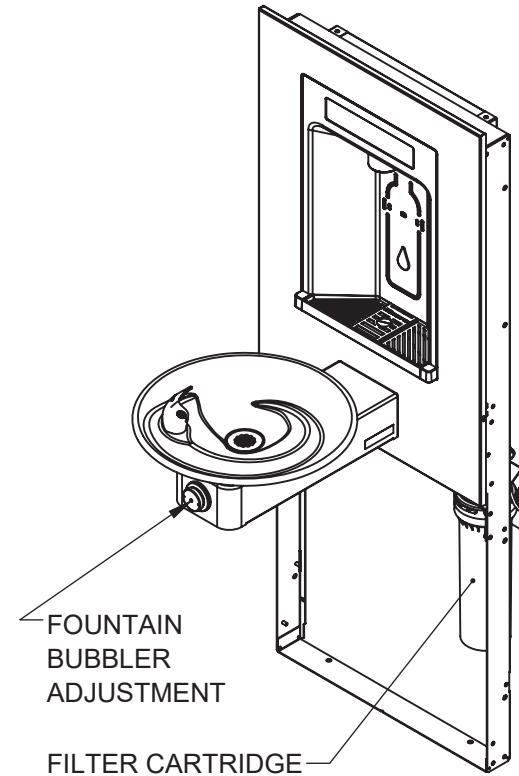

FILTER INSTALL & BUBBLER ADJUSTMENT

 Haws Since 1906		1455 KLEPPE LANE SPARKS, NEVADA 89431 (775) 359-4712 FAX (775) 359-7424 E-MAIL: HAWS@HAWS.CO.COM WEBSITE: WWW.HAWS.CO.COM	
		ECN: 6000 DRAWN: DHP APPROVED: JU	REV. ECN: 6000 DATE: 12/15/22 DATE: 07/08/24
			PART NUMBER: 0510002220.D REVISION: 1
SCALE: 1:12		DRAWING TYPE: INSTALLATION	
SIZE: A		SHEET 11 OF 11	