

FEATURES & BENEFITS

OPTIONS

For more information, visit www.hawesco.com or call (888) 640-4297.



SPECIFICATIONS

Model BP15WC is an optional back panel for use with the 1311/1920W and 1920WHO fountain/bottle filler combinations when child-height ADA requirements must be met. This back panel is 15" x 22-1/4" (38 x 54 cm) stainless steel with a white powder-coat finish.

APPLICATIONS

THIS DOCUMENT IS TRUE AND CORRECT AT TIME OF PUBLICATION. CONTINUED PRODUCT IMPROVEMENTS MAKE SPECIFICATIONS AND MEASUREMENTS SUBJECT TO CHANGE WITHOUT NOTICE.

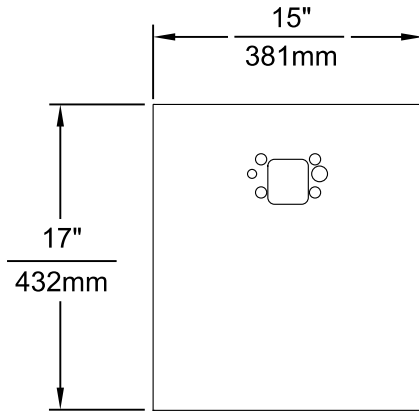

MODEL BP15 / BP15HPS / BP15W

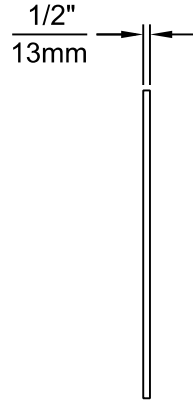

MODEL BP32 / BP32HPS / BP32W

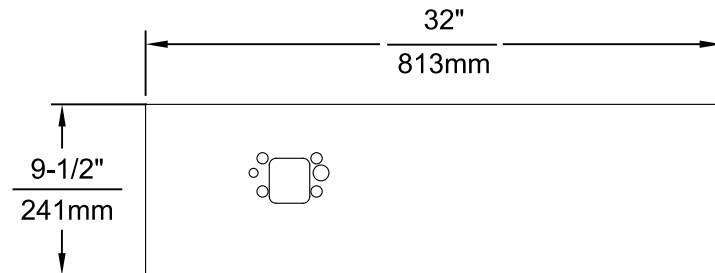
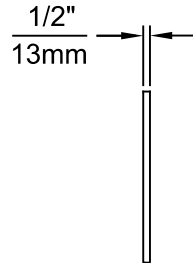

MODEL BP32R / BP32RW

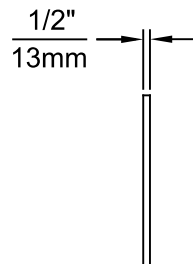

NOTES:

1. WHEN INSTALLING THIS UNIT, LOCAL, STATE OR FEDERAL CODES SHOULD BE ADHERED TO.
2. BOTTLE FILLER SHOWN FOR REFERENCE ONLY (NOT SUPPLIED).

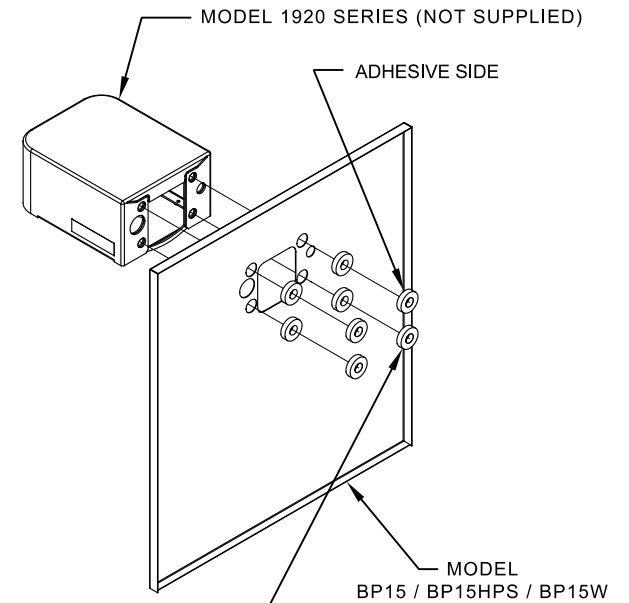

8 SPACERS (2 PER MOUNTING BOLT IF THE MOUNTING PLATE (MODEL 6700 - NOT SUPPLIED) IS INSTALLED BEHIND THE FINISHED WALL. USE 1 SPACER PER BOLT FOR RETROFITS WHERE THE MOUNTING PLATE (MODEL 6700R - NOT SUPPLIED) IS INSTALLED IN FRONT OF THE FINISHED WALL)

INSTALLATION OVER SINGLE FOUNTAIN

SHOWN FROM REAR

(SEE SHEET 3 OF 3 FOR INSTALLATION OF SPACERS ON COMBINATION BOTTLE FILLER AND FOUNTAIN BACK PANELS FOR CHILD HEIGHT APPLICATIONS - MODELS BP15C & BP15WC)



1455 KLEPPE LANE
SPARKS, NEVADA 89431
(775) 359-4712 FAX (775) 359-7424
E-MAIL: HAWS@HAWS.CO.COM
WEBSITE: WWW.HAWS.CO.COM

ECN NO. 5081	REVISED PER ECN: 5972	BY: FV	MODEL(S)	PART NUMBER
DRAWN: MJ	DATE: 06/27/16	CHK'D: JC	DRAWING, BACK PANEL, SPACER INSTALLATION FOR BP15 SERIES & BP32 SERIES, BOTTLE FILLER	0510000493
APPROVED: FV	DATE: 04/15/24	SCALE: 1:1	DRAWING TYPE: INSTALLATION	REVISION 5
			SIZE: A	SHEET 1 OF 3

THIS DOCUMENT IS TRUE AND CORRECT AT TIME OF PUBLICATION. CONTINUED PRODUCT IMPROVEMENTS MAKE SPECIFICATIONS AND MEASUREMENTS SUBJECT TO CHANGE WITHOUT NOTICE.

STEP 1

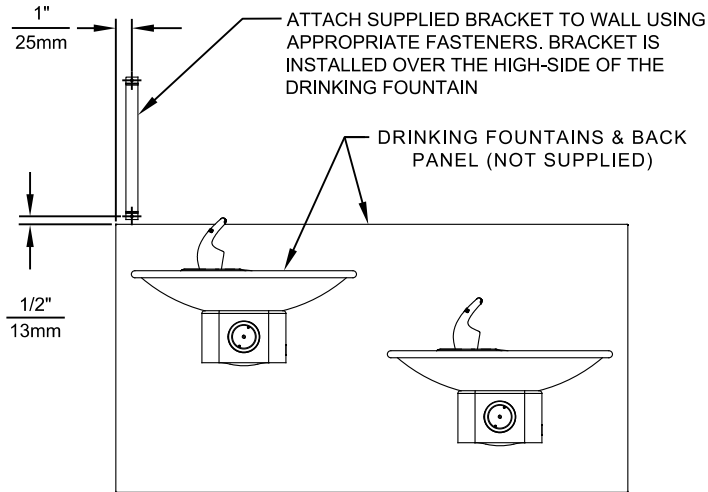

STEP 2

PLACE THE BACKPLATE AGAINST THE WALL AND SLIDE SIDEWAYS SO THE TABS CATCH UNDER THE BRACKET.

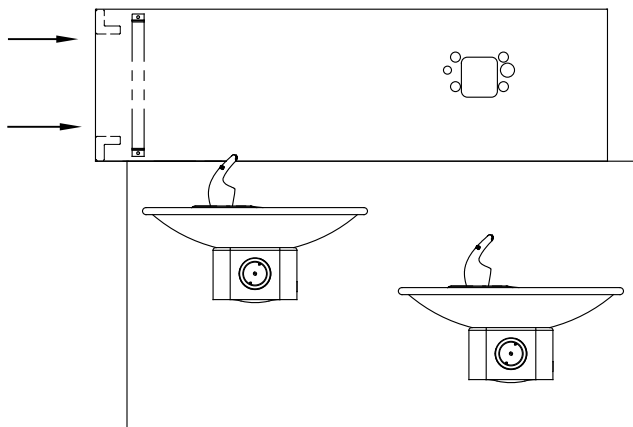

STEP 3

INSTALL THE BOTTLE FILLER (NOT SUPPLIED) PER THE INSTRUCTIONS SUPPLIED WITH THE UNIT.

NOTES:

1. WHEN INSTALLING THIS UNIT, LOCAL, STATE OR FEDERAL CODES SHOULD BE ADHERED TO.
2. BOTTLE FILLERS, DRINKING FOUNTAINS & DRINKING FOUNTAIN BACK PANELS SHOWN FOR REFERENCE ONLY (NOT SUPPLIED).

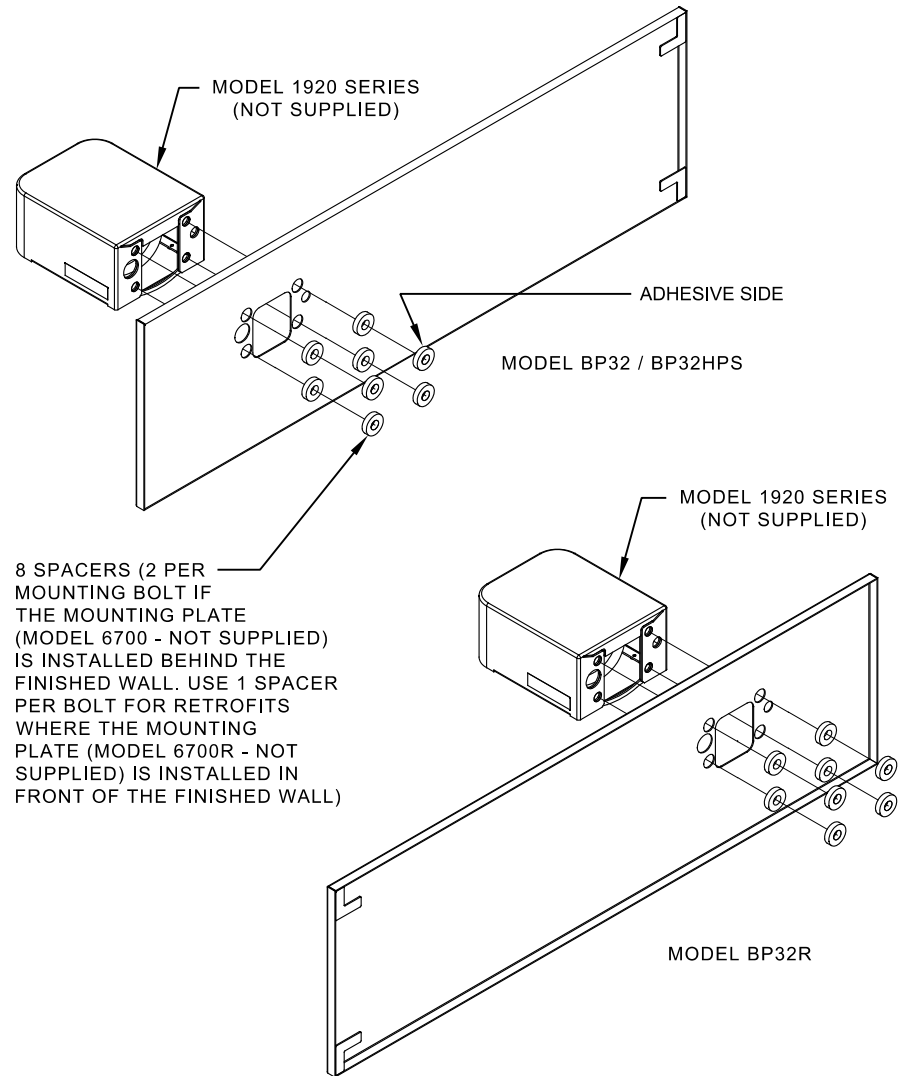

INSTALLATION OVER DOUBLE FOUNTAIN
SHOWN FROM REAR

		1455 KLEPPE LANE SPARKS, NEVADA 89431 (775) 359-4712 FAX (775) 359-7424 E-MAIL: HAWS@HAWSO.COM WEBSITE: WWW.HAWSO.COM	
		ECN NO. 5081 DRAWN: MJ APPROVED: FV	REVISED PER BY: ECN: 5972 FV DATE: 02/02/17 DATE: 04/15/24
SCALE: 1:1		DRAWING TYPE: INSTALLATION	SIZE: A SHEET 2 OF 3

THIS DOCUMENT IS TRUE AND CORRECT AT TIME OF PUBLICATION. CONTINUED PRODUCT IMPROVEMENTS MAKE SPECIFICATIONS AND MEASUREMENTS SUBJECT TO CHANGE WITHOUT NOTICE.

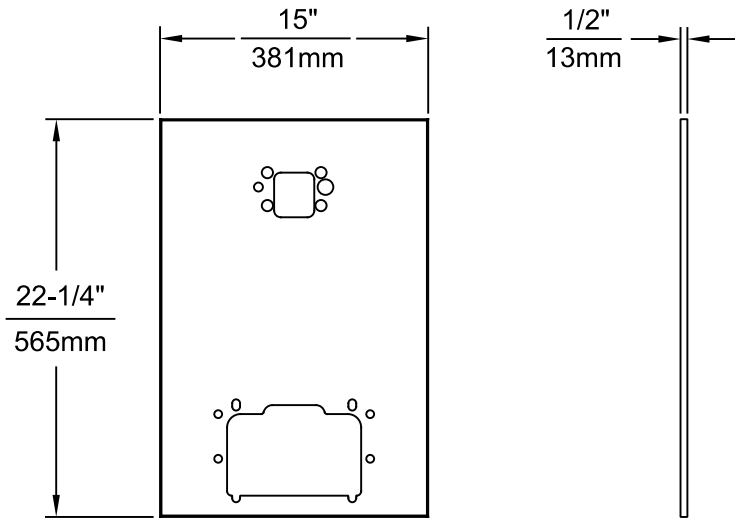

MODEL BP15C
(FOR MODELS 1107L & 1109)

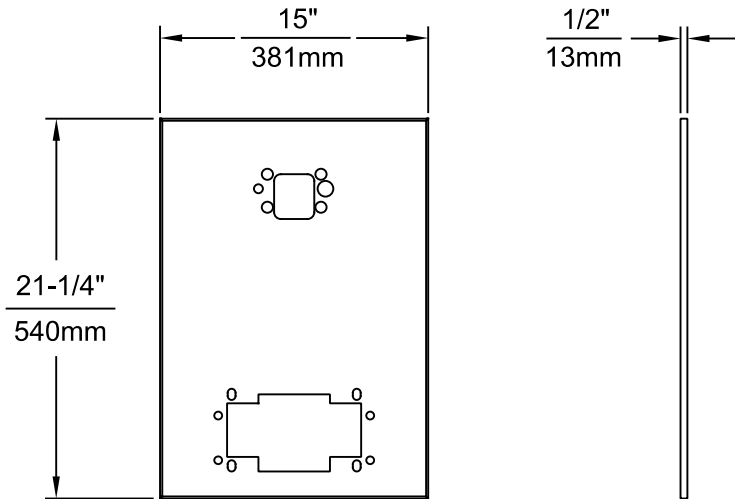

MODEL BP15WC
(FOR MODEL 1311)

NOTES:

1. WHEN INSTALLING THIS UNIT, LOCAL, STATE OR FEDERAL CODES SHOULD BE ADHERED TO.
2. BOTTLE FILLER AND DRINKING FOUNTAIN SHOWN FOR REFERENCE ONLY (NOT SUPPLIED).

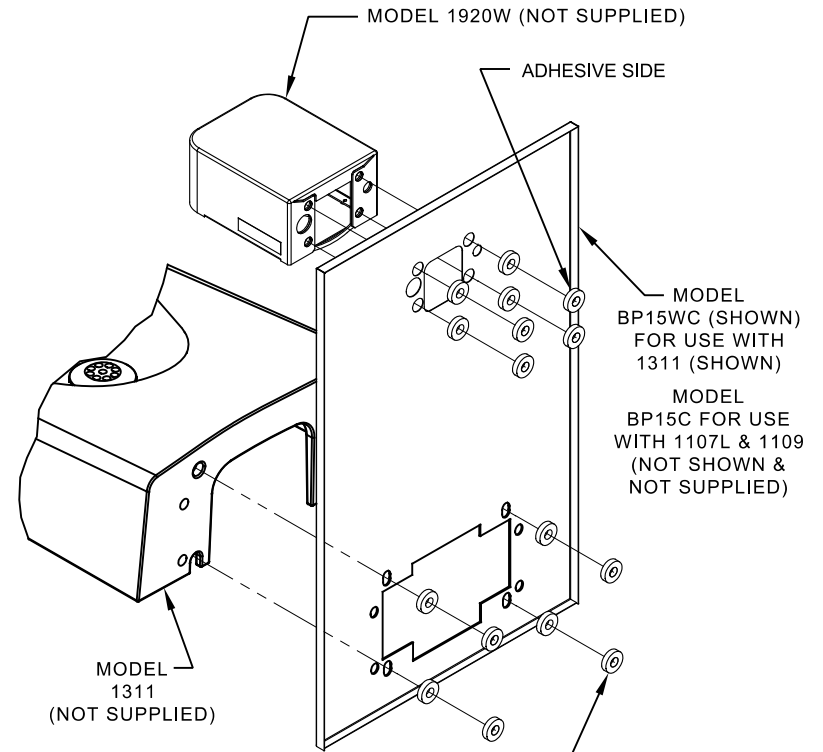

16 SPACERS (2 PER MOUNTING BOLT IF BOTH MOUNTING PLATES (MODEL 6700 - NOT SUPPLIED) ARE INSTALLED BEHIND THE FINISHED WALL. USE 1 SPACER PER BOLT FOR RETROFITS WHERE BOTH MOUNTING PLATES (MODEL 6700R - NOT SUPPLIED) ARE INSTALLED IN FRONT OF THE FINISHED WALL)

ONE PIECE INSTALLATION ON SINGLE FOUNTAIN

SHOWN FROM REAR

(MODEL BP15C & BP15WC ARE COMBINATION BOTTLE FILLER AND FOUNTAIN BACK PANELS USED FOR CHILD HEIGHT APPLICATIONS ONLY ON MODELS 1107L, 1109 & 1311 - BOTTLE FILLER & DRINKING FOUNTAIN NOT SUPPLIED)



1455 KLEPPE LANE
SPARKS, NEVADA 89431
(775) 359-4712 FAX (775) 359-7424
E-MAIL: HAWS@HAWSO.COM
WEBSITE: WWW.HAWSO.COM

ECN NO. 5972	REVISED PER ECN: 5972	BY: FV	MODEL(S)	PART NUMBER
DRAWN: FV	DATE: 12/13/23	CHK'D: JC	DRAWING, BACK PANEL, SPACER INSTALLATION	0510000493
APPROVED: FV	DATE: 04/15/24		FOR BP15 SERIES & BP32 SERIES, BOTTLE FILLER	REVISION 5
			SCALE: 1:1	DRAWING TYPE: INSTALLATION
			SIZE: A	SHEET 3 OF 3