

FEATURES & BENEFITS

CONSTRUCTION

Heavy-duty cast-iron ADA accessible bowl with a glossy white enamel finish is designed for the toughest of applications, and at the same time is gentle to all users with its soft rounded corners. Unit also ships with vandal-resistant bottom plates to provide added peace of mind.

BOTTLE FILLER

Vandal-resistant, 14-gauge white powder-coated Type 304 stainless steel bottle filler housing with push button operation and 1 gpm (3.78 L) laminar flow.

BUBBLER HEAD

Polished chrome-plated brass bubbler head with integral laminar flow prevents splashing while providing a superior flow pattern. The integral 11/16" dia. basin shank and stainless anti-rotation roll pin for vandal resistance strength. Shielded, angled stream opening provides a steady, sanitary source of drinking water at .45 gpm.

FOUNTAIN VALVES

The push-button activated valves have all stainless steel bodies, with chrome plated brass push button assemblies which allow for front access to water stream adjustment, water control cartridge, and water supply strainer replacement without having to go through the bottom plate. Operating pressure range of 30 to 90 psi (2.1 to 6.2 bar).

VANDAL RESISTANT

The bubbler head, push buttons, drain strainer and bottom plates are locked in place, discouraging unwanted vandal tampering.

OPTIONS

- Water Filter: Model 6480 filter kit with 3000 gallon carbon block filter, filter head, and mounting bracket.
- Back Panel: Model BP15WC, one-piece panel for fountain/bottle filler combination when child-height ADA requirements are needed.
- Mounting Plate: Model 6700, in-wall mounting plate for model 1920W and/or 1311.
- Mounting Plate: Model 6700R, on-wall mounting plate for model 1920W.
- Support Frame: Model 6800 In-wall floor mounted fixture support legs, welded steel 4-bolt floor flanges, and supplied with 'U' bolts and hardware.

For more information, visit www.hawscow.com or call (888) 640-4297.



SPECIFICATIONS

1311 / BP8W / 1920W / BP15W

Order these items to make up the Model 1311-1920W white enameled-iron fountain and white painted stainless steel bottle filler.

APPLICATIONS

Model 1311-1920W wall mounted vandal-resistant ADA drinking fountain and bottle filler shall include a white enameled-iron basin with 14 gauge Type 304 powder-coated Stainless Steel bottle filler bracket, 100% lead-free waterways, vandal-resistant push-button operated stainless steel valves with front-accessible cartridge and flow adjustment, polished chrome-plated brass vandal-resistant bubbler head with integral anti-squirt flow, 1 gpm (3.78 L) laminar flow bottle filler, chrome plated brass vandal-resistant waste strainer, vandal-resistant bottom plates, and a 1-1/4" NPT trap. Manufactured to be lead-free by all known definitions including NSF/ ANSI/CAN 61-Section 9, NSF/ANSI/CAN 372, California Proposition 65, and the Federal Safe Drinking Water Act. Product is compliant to California Health and Safety Code 116875 (AB 1953-2006), and 116876 (AB 100) "NSF/ANSI/CAN 61: Q ≤ 1".

The bottle filler requires a mounting plate; either the Haws model 6700 in-wall or the 6700R on-wall support plate.



1. HOLD ROUGH-IN DIMENSIONS $\pm 1/4"$ (6.4MM).
2. WHEN INSTALLING THIS UNIT, LOCAL, STATE, OR FEDERAL CODES SHOULD BE ADHERED TO. FOR INSTALLATION HEIGHTS OTHER THAN SHOWN, DIMENSIONS MARKED (*) MUST BE ADJUSTED ACCORDINGLY.
3. REFER TO 5874 SERIES VALVE OPERATION AND MAINTENANCE MANUAL FOR PUSH BUTTON AND VALVE INSTALLATION/MAINTENANCE INSTRUCTIONS.

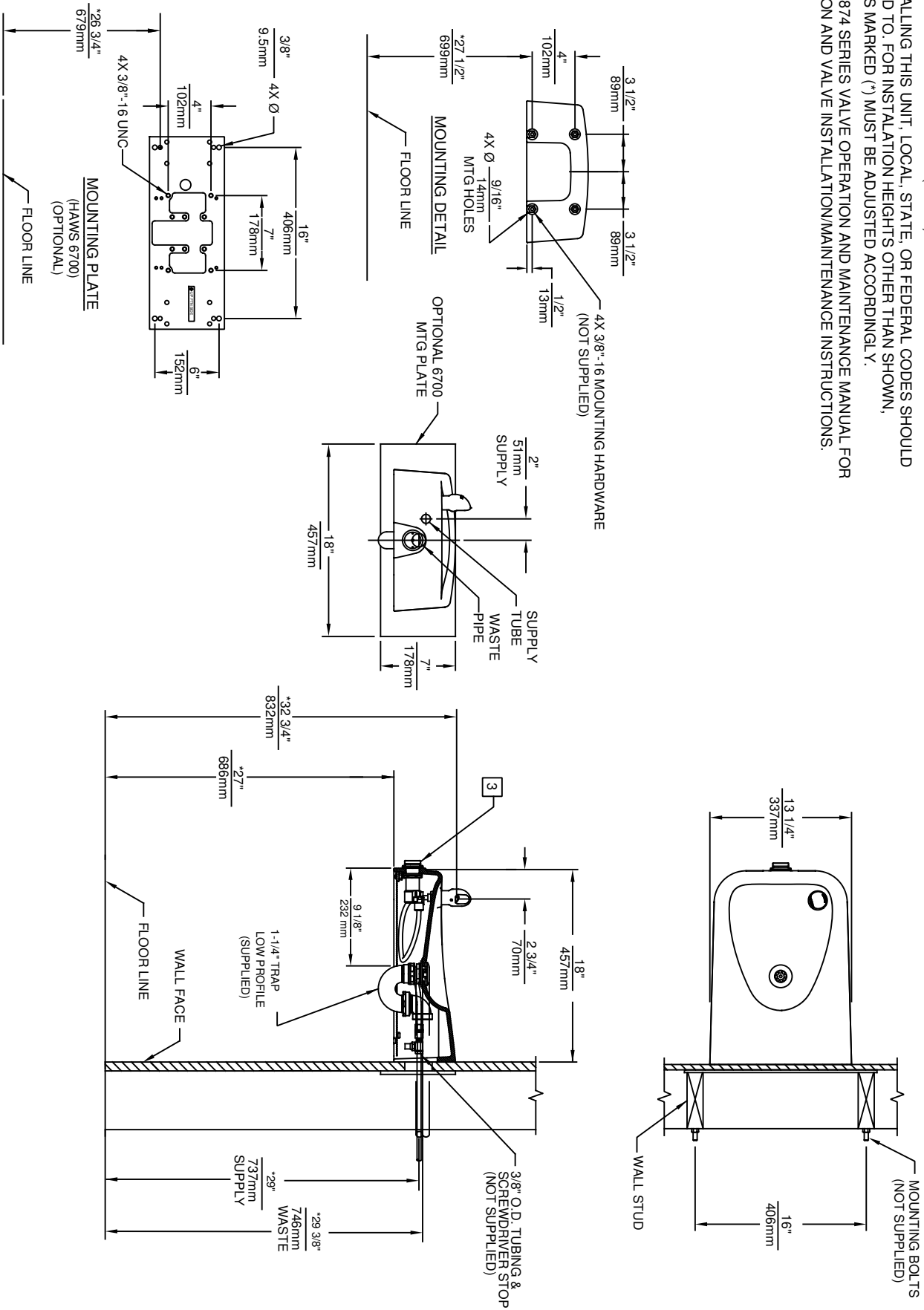

1459 KLEPPE LANE
SPARKS, NEVADA 89431
(775) 359-4712 FAX (775) 359-7424
E-MAIL: HAWSS@HAWSSCO.COM
WEBSITE: WWW.HAWSSCO.COM

ECN NO. REVISED PER BY:	MODEL(S)	PART NUMBER
5010		0510000046.D
DATE:	CHKD:	REVISION:
08/25/15	GC	4
APPROVED:	SCALE:	DRAWING TYPE:
FV	1:14	INSTALLATION
DATE:	11/23/17	SHEET:
		1 OF 1

THIS DOCUMENT IS TRUE AND CORRECT AT TIME OF PUBLICATION. CONTINUED PRODUCT IMPROVEMENTS MAKE SPECIFICATIONS AND MEASUREMENTS SUBJECT TO CHANGE WITHOUT NOTICE.

6700 MOUNTING PLATE
(BEHIND FINISH WALL)
-OR-
BOLT 1920 ON TO
EXISTING WALL

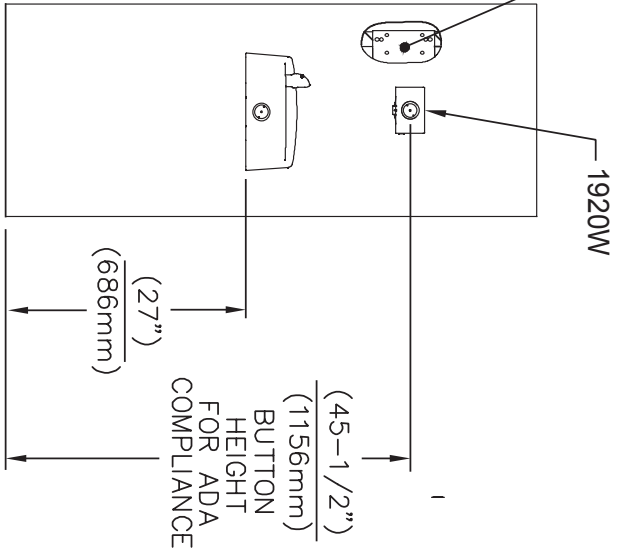

INSTALLATION ABOVE HAWS 1311

* IF YOUR FOUNTAIN IS THIS STYLE USE THESE DIMENSIONS

1. SEE SEPERATE INSTALLATION DRAWINGS FOR MOUNTING PLATES AND BACKPANELS
2. WHEN INSTALLING THIS UNIT, LOCAL, STATE OR FEDERAL CODES SHOULD BE ADHERED TO FOR INSTALLATION LOCATIONS, WASTE & SUPPLY REQUIREMENTS OTHER THAN SHOWN.

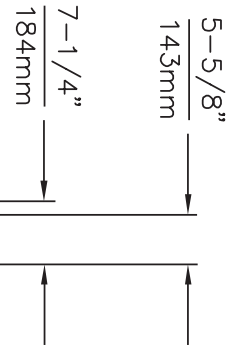
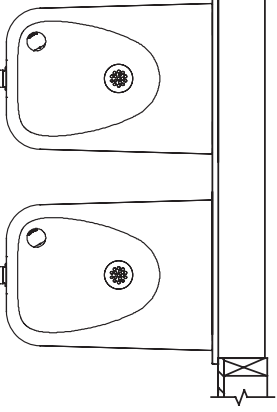

3/8" PUSH IN TEE
(CONNECT TO
FOUNTAIN SUPPLY)



HAWS

1455 KLEPPE LANE
SPARKS, NEVADA 89431
(775) 359-4712 FAX (775) 359-7424
E-MAIL: HAWS@HAWS.CO.COM
WEBSITE: WWW.HAWS.CO.COM

ECN NO.	REVISOR	PER	BY	MODEL(S)
DATE	DATE	CHRD.		MODEL 1311
APPROVED	SCALE	VA	DRAWING TYPE	INSTALLATION
				WITH MODEL 1920 BOTTLE FILLER
				PART NUMBER
				1311-20
				REVISION
				0A.1
				SIZE: A1 SHEET 1 OF 1

©2017 Haws Corporation - All Rights Reserved. HAWS® and other trademarks used in these materials are the exclusive property of Haws Corporation.

THIS DOCUMENT IS TRUE AND CORRECT AT TIME OF PUBLICATION. CONTINUED PRODUCT IMPROVEMENTS MAKE SPECIFICATIONS AND MEASUREMENTS SUBJECT TO CHANGE WITHOUT NOTICE.

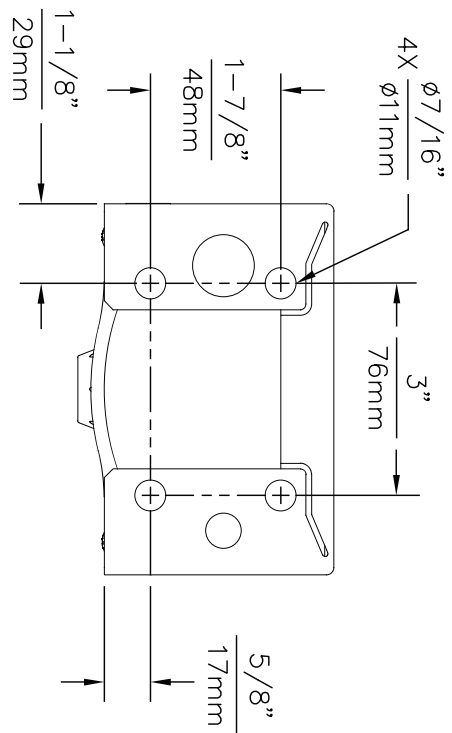
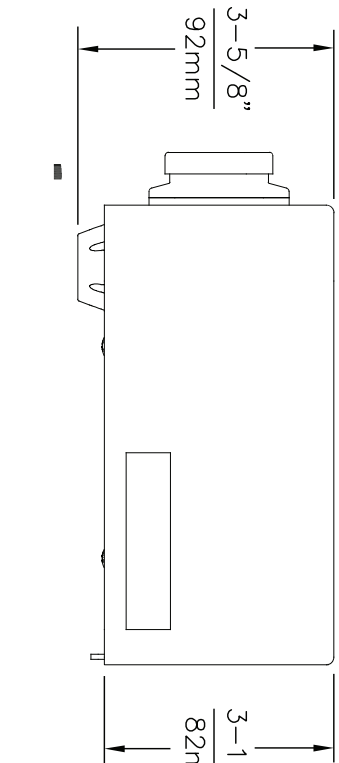

1920 MOUNTING HOLE LOCATIONS

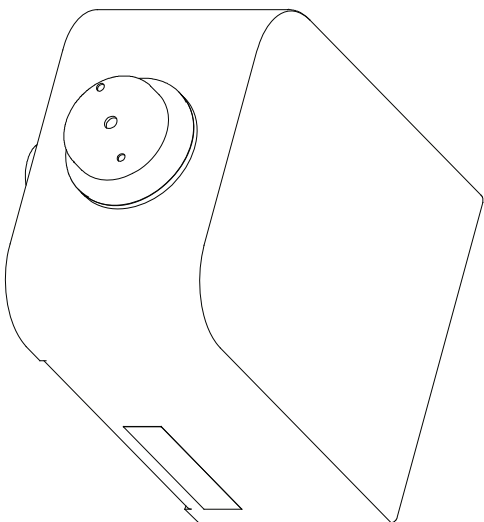
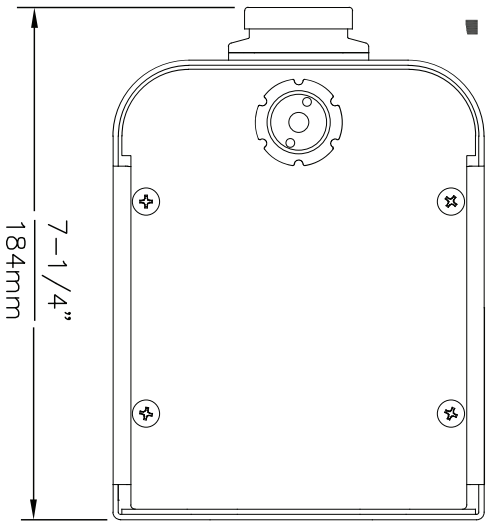

NOTES:

1. SEE SEPERATE INSTALLATION DRAWINGS FOR MOUNTING PLATES AND BACKPANELS
2. WHEN INSTALLING THIS UNIT, LOCAL, STATE OR FEDERAL CODES SHOULD BE ADHERED TO FOR INSTALLATION LOCATIONS, WASTE & SUPPLY REQUIREMENTS OTHER THAN SHOWN.

©2017 Haws Corporation - All Rights Reserved. HAWS® and other trademarks used in these materials are the exclusive property of Haws Corporation.

		Haws	
ECN/D	REISED REF BY	MODEL(S)	
5081	ECN: 5172	MJ	MODEL 1920/1920HPS/1920W
DRAWN	DATE	CHK'D	
DS	05/23/16	FV	
APPROVED:	DATE	SCALE	INSTALLATION
NA	6/27/17	NA	
		PART NUMBER	0510000490.D
		REVISION	2
1455 KLEPPE LANE SPARKS, NEVADA 89431 (775) 359-4712 FAX (775) 359-7424 E-MAIL: HAWS@HAWSCO.COM WEBSITE: WWW.HAWSCO.COM			

THIS DOCUMENT IS TRUE AND CORRECT AT TIME OF PUBLICATION. CONTAINED PRODUCT IMPROVEMENTS HAVE SPECIFICATIONS AND MEASUREMENTS SUBJECT TO CHANGE WITHOUT NOTICE.

DUAL FOUNTAIN
SHOWN FROM REAR

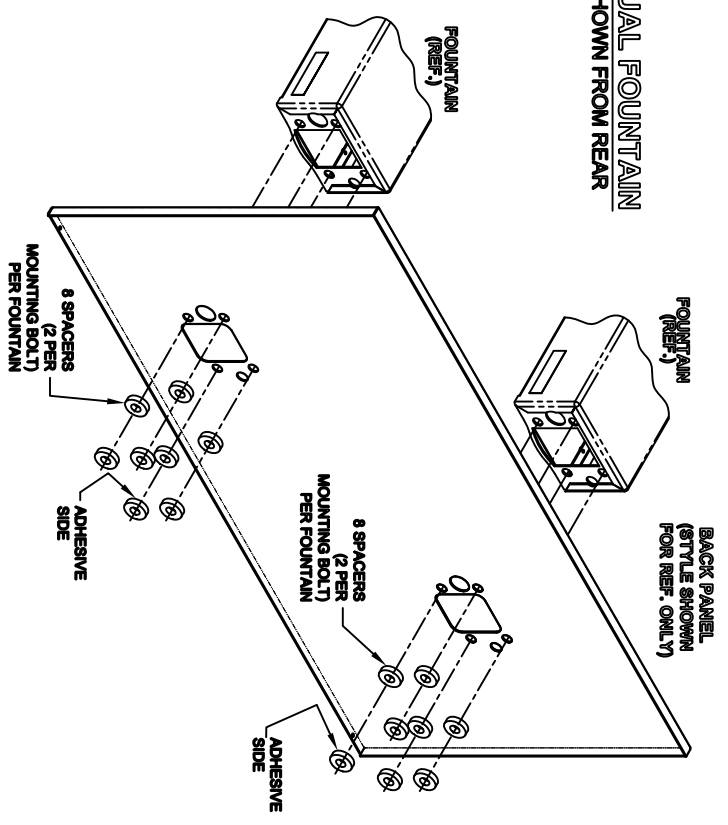

- NOTES:**
- 1 ON ALL BACK PANEL MODELS, SPACERS ARE NOT USED WHEN A MOUNTING FRAME IS USED EXCEPT AS SPECIFIED IN NOTE 2
 - 2 INDICATED SPACERS ARE USED WITH MOUNTING FRAME (DUAL ADJUSTABLE)

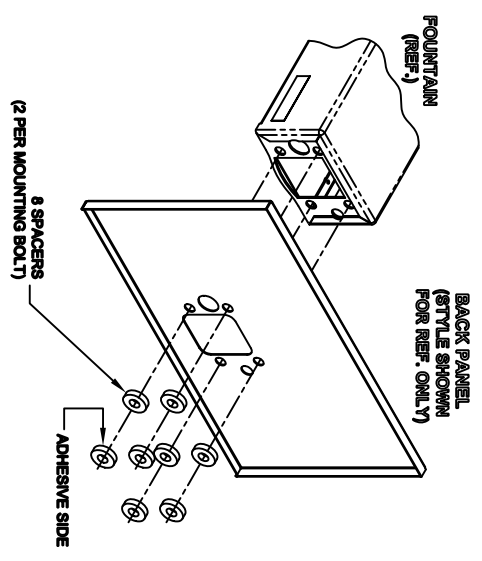

SINGLE FOUNTAIN
SHOWN FROM REAR

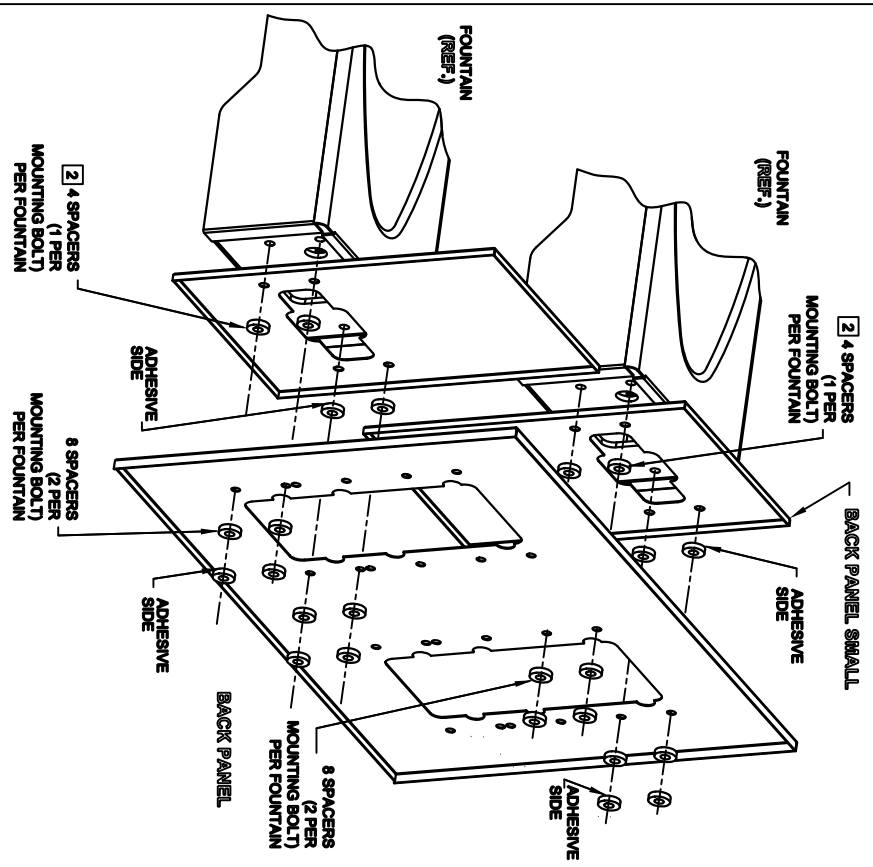

DUAL FOUNTAIN ADJUSTABLE
SHOWN FROM REAR

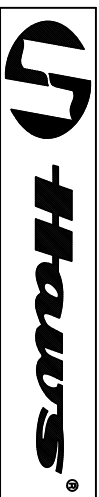

1465 KLEPPE LANE
SPARKS, NEVADA, 89431
(775) 399-4712 FAX (759) 399-1424
E-MAIL: HAWS@HAWS.CO.COM
WEBSITE: WWW.HAWS.CO.COM

ECN NO. REVISED PER BY:	MODEL(S)	BACK PANEL
DRAWN: []	DATE: []	SPACER INSTRUCTIONS
CHKD: []	DATE: []	INSTALLATION
APPROVED: []	DATE: []	SIZE: A
	SCALE: 1:10	DRAWING TYPE:
		SHEET: 1 OF 1
		REV: 5
		PART NUMBER: 0002082219